

Model G-P1
(Machine Code: G104/G105)

SERVICE MANUAL

Subject to change
12 November 2004

IMPORTANT SAFETY NOTICES

PREVENTION OF PHYSICAL INJURY

1. Before disassembling or assembling parts of the printer and peripherals, make sure that the printer power cord is unplugged.
2. The wall outlet should be near the printer and easily accessible.
3. If any adjustment or operation check has to be made with exterior covers off or open while the main switch is turned on, keep hands away from electrified or mechanically driven components.
4. The printer drives some of its components when it completes the warm-up period. Be careful to keep hands away from the mechanical and electrical components as the printer starts operation.
5. The inside and the metal parts of the fusing unit become extremely hot while the printer is operating. Be careful to avoid touching those components with your bare hands.

HEALTH SAFETY CONDITIONS

Toner and developer are non-toxic, but if you get either of them in your eyes by accident, it may cause temporary eye discomfort. Immediately wash eyes with plenty of water. If unsuccessful, get medical attention.

OBSERVANCE OF ELECTRICAL SAFETY STANDARDS

The printer and its peripherals must be serviced by a customer service representative who has completed the training course on those models.

LITHIUM BATTERIES

Incorrect replacement of lithium battery(s) on the EGB may pose risk of explosion. Replace only with the same type or with an equivalent type recommended by the manufacturer. Discard used batteries in accordance with the manufacturer's instructions.

SAFETY AND ECOLOGICAL NOTES FOR DISPOSAL

1. Do not incinerate toner bottles or used toner. Toner dust may ignite suddenly when exposed to an open flame.
2. Dispose of used toner, the maintenance unit which includes developer or the organic photoconductor in accordance with local regulations. (These are non-toxic supplies.)
3. Dispose of replaced parts in accordance with local regulations.
4. When keeping used lithium batteries in order to dispose of them later, do not put more than 100 batteries per sealed box. Storing larger numbers or not sealing them apart may lead to chemical reactions and heat build-up.

LASER SAFETY

The Center for Devices and Radiological Health (CDRH) prohibits the repair of laser-based optical units in the field. The optical housing unit can only be repaired in a factory or at a location with the requisite equipment. The laser subsystem is replaceable in the field by a qualified Customer Engineer. The laser chassis is not repairable in the field. Customer engineers are therefore directed to return all chassis and laser subsystems to the factory or service depot when replacement of the optical subsystem is required.

WARNING

Use of controls, or adjustment, or performance of procedures other than those specified in this manual may result in hazardous radiation exposure.

WARNING

WARNING: Turn off the main switch before attempting any of the procedures in the Laser Optics Housing Unit section. Laser beams can seriously damage your eyes.

CAUTION MARKING:

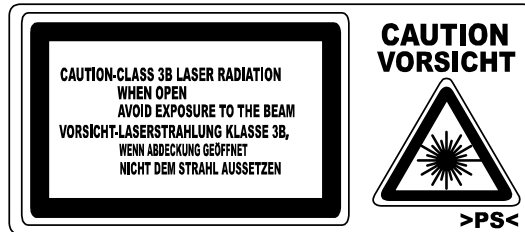

Trademarks

Microsoft®, Windows®, and MS-DOS® are registered trademarks of Microsoft Corporation in the United States and /or other countries.

PostScript® is a registered trademark of Adobe Systems, Incorporated.

PCL® is a registered trademark of Hewlett-Packard Company.





Ethernet® is a registered trademark of Xerox Corporation.

PowerPC® is a registered trademark of International Business Machines Corporation.

Other product names used herein are for identification purposes only and may be trademarks of their respective companies. We disclaim any and all rights involved with those marks.

Symbols and Abbreviations

This manual uses the symbols and abbreviations shown below.

Symbol	Meaning
	Refer to section number
	Clip ring
	Screw
	Connector
	Clamp
SEF	Short Edge Feed
LEF	Long Edge Feed

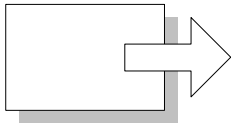

Short Edge Feed (SEF)

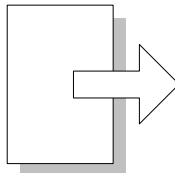

Long Edge Feed (LEF)

TABLE OF CONTENTS

1. INSTALLATION	1-1
1.1 INSTALLATION REQUIREMENTS	1-1
1.1.1 ENVIRONMENT	1-1
1.1.2 MACHINE LEVEL	1-1
1.1.3 MACHINE SPACE REQUIREMENT	1-2
1.1.4 POWER REQUIREMENTS	1-2
1.2 MACHINE INSTALLATION.....	1-3
1.2.1 UNPACKING	1-3
1.2.2 INSTALLING THE TONER BOTTLE	1-5
1.2.3 LOADING PAPER	1-7
1.2.4 CONNECTING THE POWER CORD	1-9
1.2.5 SELECTING THE PANEL DISPLAY LANGUAGE.....	1-10
1.2.6 PRINTING THE TEST PAGE	1-10
1.3 OPTIONAL UNIT INSTALLATION.....	1-11
1.4 METER CHARGE.....	1-12
1.5 TRAY HEATER	1-13
2. PREVENTATIVE MAINTENANCE	2-1
2.1 USER REPLACEABLE ITEMS.....	2-1
2.2 SERVICE MAINTENANCE.....	2-2
2.2.1 RECOMMENDED CLEANING PROCEDURE.....	2-2
3. REPLACEMENT AND ADJUSTMENT.....	3-1
3.1 SPECIAL TOOLS AND LUBRICANTS	3-1
3.1.1 TOOLS	3-1
3.2 ELECTRICAL COMPONENTS.....	3-2
3.2.1 ELECTRICAL BOARD UNIT	3-2
3.2.2 IOB (INPUT/OUTPUT BOARD).....	3-4
3.2.3 CONTROLLER BOARD	3-4
3.2.4 PSU (POWER SUPPLY UNIT) BOARD	3-5
3.2.5 HIGH VOLTAGE POWER SUPPLY BOARD 1	3-5
3.2.6 EGB (ENGINE BOARD) AND HIGH VOLTAGE POWER SUPPLY BOARD 2.....	3-6
3.2.7 LCD PANEL.....	3-6
3.2.8 NVRAM REPLACEMENT PROCEDURE	3-7
NVRAM on the EGB (Engine Board)	3-7
NVRAM on the Controller	3-8
NVRAMs on the EGB and Controller	3-9
3.3 LASER OPTICS	3-10
3.3.1 CAUTION DECAL LOCATIONS.....	3-10
3.3.2 LD UNIT.....	3-11
Color registration adjustment.....	3-11
3.3.3 LDB.....	3-13
3.3.4 POLYGON MIRROR MOTOR.....	3-13
3.3.5 LASER SYNCHRONIZING DETECTOR BOARDS	3-14

3.3.6	LDU SHUTTER MOTOR UNIT AND SENSOR	3-14
3.4	PAPER FEED	3-15
3.4.1	PAPER FEED ROLLER.....	3-15
3.4.2	PAPER FRICTION PAD	3-16
3.4.3	BY-PASS PAPER SIZE SENSOR.....	3-16
3.4.4	BY-PASS FEED ROLLER, FRICTION PAD	3-17
3.4.5	REGISTRATION SENSOR.....	3-18
3.4.6	PAPER VOLUME SENSOR, END SENSOR AND PAPER WIDTH SENSOR.....	3-19
3.4.7	PAPER SIZE SENSOR AND TEMPERATURE/ HUMIDITY SENSOR	3-20
3.4.8	PAPER FEED MOTOR.....	3-21
3.4.9	PAPER REGISTRATION CLUTCH, PAPER FEED CLUTCH AND BY-PASS CLUTCH	3-22
3.5	DEVELOPMENT	3-23
3.5.1	COLOR DEVELOPMENT MOTOR, COLOR OPC MOTOR AND BLACK OPC/DEVELOPMENT MOTOR	3-23
3.5.2	DEVELOPMENT CLUTCH	3-23
3.5.3	TRANSFER BELT CONTACT MOTOR.....	3-24
3.5.4	TONER SUPPLY MOTOR.....	3-24
3.5.5	TRANSFER ROLLER CONTACT MOTOR	3-25
3.5.6	ID SENSORS	3-26
3.6	DRIVE	3-26
3.6.1	DRIVE UNIT	3-26
3.7	DUPLEX	3-27
3.7.1	DUPLEX JAM SENSOR.....	3-27
3.7.2	INVERTER SENSOR	3-27
3.7.3	DUPLEX MOTOR AND INVERTER MOTOR.....	3-28
3.8	FUSING.....	3-29
3.8.1	FUSING UNIT.....	3-29
3.8.2	THERMISTOR AND THERMOSTAT	3-29
3.8.3	FUSING LAMP	3-30
3.8.4	FUSING EXIT SENSOR AND PAPER EXIT SENSOR	3-31
3.8.5	FUSING REGISTRATION SENSOR	3-31
3.8.6	FAN DIRECTION.....	3-32
3.9	ADJUSTMENTS	3-33
3.9.1	GAMMA ADJUSTMENT	3-33

4. TROUBLESHOOTING	4-1
4.1 PROCESS CONTROL RESULT	4-1
4.2 SERVICE CALL CONDITIONS	4-2
4.2.1 SUMMARY	4-2
4.2.2 SC CODE DESCRIPTIONS	4-3
Engine SC.....	4-3
Controller Error	4-14
4.3 TROUBLESHOOTING GUIDE	4-21
4.3.1 BLANK PRINT	4-21
4.3.2 ALL-BLACK PRINT.....	4-21
4.3.3 MISSING CMY COLOR.....	4-22
4.3.4 LIGHT PRINT	4-22
4.3.5 REPEATED SPOTS OR LINES ON PRINTS	4-23
4.3.6 DARK VERTICAL LINE IN PRINT	4-23
4.3.7 WHITE HORIZONTAL LINES OR BANDS.....	4-24
4.3.8 MISSING PARTS OF IMAGES.....	4-24
4.3.9 DIRTY BACKGROUND	4-24
4.3.10 PARTIAL CMY COLOR DOTS.....	4-24
4.3.11 DARK IRREGULAR STREAKS ON PRINTS.....	4-24
4.3.12 CMY COLOR IRREGULAR STREAKS	4-25
4.3.13 GHOSTING	4-25
4.3.14 UNFUSED OR PARTIALLY FUSED PRINTS	4-25
4.3.15 IMAGE SKEW.....	4-25
4.3.16 BACKGROUND STAIN	4-26
4.3.17 NO PRINTING ON PAPER EDGE.....	4-26
4.3.18 IMAGE NOT CENTERED WHEN IT SHOULD BE	4-26
4.4 ELECTRICAL COMPONENT DEFECTS	4-27
4.4.1 SENSORS	4-27
4.5 BLOWN FUSE CONDITIONS	4-29
Power supply unit.....	4-29
IOB.....	4-29
4.6 LEDS	4-29
5. SERVICE TABLES.....	5-1
5.1 SERVICE PROGRAM MODE.....	5-1
5.1.1 SERVICE MODE OPERATION	5-1
Entering the Service Mode.....	5-1
Accessing the Required Program	5-2
Inputting a Value or Setting for a Service Program	5-2
Exiting Service Mode	5-2
5.1.2 REMARKS.....	5-3
Display on the Control Panel Screen	5-3
Others	5-4
5.1.3 BIT SWITCH PROGRAMMING	5-5
5.2 SERVICE MODE TABLE.....	5-6
5.2.1 CONTROLLER SERVICE MODE.....	5-6
5.2.2 ENGINE SERVICE MODE	5-10
SP1-XXX (Feed).....	5-10

SP2-XXX (Drum).....	5-21
SP3-XXX (Process)	5-47
SP5-XXX (Mode)	5-57
SP7-XXX (Data Log).....	5-71
SP8-XXX (Data Log 2).....	5-82
SP9-XXX.....	5-92
5.2.3 INPUT CHECK TABLE	5-96
5.2.4 OUTPUT CHECK TABLE	5-98
5.3 FIRMWARE UPDATE	5-100
5.3.1 TYPE OF FIRMWARE.....	5-100
5.3.2 PRECAUTIONS.....	5-100
Handling SD Cards	5-100
Upload or Download	5-100
Network Connection.....	5-100
5.3.3 FILE ARRANGEMENT	5-101
How the Program Works.....	5-101
Example.....	5-101
5.3.4 UPDATING	5-102
Procedure	5-102
Error Handling.....	5-103
Power Failure.....	5-103
5.3.5 NVRAM DATA UPLOAD/DOWNLOAD	5-104
Uploading NVRAM Data	5-104
Downloading NVRAM Data.....	5-105
5.3.6 ERROR CODE TABLE	5-106
5.4 SD CARD APPLI MOVE.....	5-107
5.4.1 OVERVIEW	5-107
5.4.2 MOVE EXEC	5-108
5.4.3 UNDO EXEC	5-109
Keeping the SD card.....	5-109
5.5 CONTROLLER SELF-DIAGNOSTICS	5-110
6. DETAILED SECTION DESCRIPTIONS	6-1
6.1 OVERVIEW	6-1
6.1.1 COMPONENT LAYOUT	6-1
6.1.2 PAPER PATH.....	6-2
6.1.3 DRIVE LAYOUT	6-3
6.1.4 BOARD STRUCTURE.....	6-4
Descriptions	6-5
6.1.5 PRINTING PROCESS	6-6

6.2	PROCESS CONTROL	6-8
6.2.1	OVERVIEW	6-8
6.2.2	POTENTIAL CONTROL	6-9
	Overview	6-9
	Process Control Self-check.....	6-9
6.2.3	PROCESS CONTROL SELF-CHECK PROCEDURE	6-11
	Step 1: VSG Adjustment.....	6-11
	Step 2: ID Sensor Solid Pattern Generation	6-11
	Step 3: Sensor Pattern Detection	6-11
	Step 4: Toner Amount Calculation	6-11
	Step 5: VD, VB, VL Selection and VREF Adjustment	6-12
6.2.4	TONER SUPPLY CONTROL	6-12
	Toner Supply Control Modes	6-12
	Low Image Coverage.....	6-13
6.2.5	TONER NEAR END/TONER END DETECTION	6-14
	Introduction	6-14
	Toner Near End Detection	6-15
	Toner End Detection.....	6-15
	Toner End Recovery.....	6-15
6.2.6	DEVELOPER INITIALIZATION	6-16
6.3	PAPER FEED.....	6-17
6.3.1	OVERVIEW	6-17
6.3.2	PAPER FEED DRIVE.....	6-18
6.3.3	PAPER TRAY	6-19
	Paper Lift	6-19
	Paper Size Detection	6-20
	Paper Size Detection	6-20
	Paper Near End/End Detection.....	6-21
	Near-end detection	6-21
	End detection.....	6-21
	Paper width sensor	6-21
	By-pass Tray Feed and Size Detection.....	6-22
6.3.4	DUPLEX	6-23
	Drive	6-24
	Interleaving	6-25
6.4	LASER EXPOSURE	6-26
6.4.1	OVERVIEW	6-26
6.4.2	OPTICAL PATH.....	6-27
6.4.3	LASER SYNCHRONIZING DETECTOR	6-28
	Overview	6-28
	Main Scan Start Detection	6-28
6.4.4	LD SAFETY SWITCH.....	6-29
6.4.5	AUTOMATIC LINE POSITION ADJUSTMENT.....	6-30
	Overview.....	6-30
	Summary of Each Adjustment	6-31
	Main Scan Skew Adjustment	6-34
	LDU Shutter	6-35
6.5	PHOTOCONDUCTOR UNIT	6-36
6.5.1	OVERVIEW	6-36

6.5.2	DRIVE AND DRIVE GEAR POSITION SENSOR	6-37
	Mechanism	6-37
	Initialization Process and SC Codes	6-38
6.5.3	DRUM CHARGE AND QUENCHING	6-39
6.5.4	DRUM CLEANING.....	6-40
6.5.5	WASTE TONER COLLECTION.....	6-41
6.5.6	WASTE TONER BOTTLE FULL DETECTION AND SET DETECTION.....	6-42
6.5.7	PCU DETECTION (DEVELOPMENT UNIT DETECTION).....	6-43
	Unit Set Detection Pins	6-43
	New Unit Detection	6-43
	Error Message	6-44
6.6	DEVELOPMENT	6-45
6.6.1	OVERVIEW	6-45
6.6.2	DRIVE.....	6-46
6.6.3	DEVELOPER MIXING	6-47
6.6.4	DEVELOPMENT BIAS	6-48
6.6.5	TONER SUPPLY MECHANISM	6-49
	Overview	6-49
	Toner Near End Detection	6-49
6.6.6	TONER BOTTLE DETECTION.....	6-49
6.7	IMAGE TRANSFER.....	6-50
6.7.1	OVERVIEW	6-50
	Transfer Unit Detection and New Unit Detection	6-51
	Transfer belt unit detection	6-51
	New transfer belt unit detection	6-51
6.7.2	DRIVE AND TRANSFER BELT ROLLER VOLTAGE.....	6-52
	Transfer belt contact	6-53
	Transfer belt cleaning	6-54
6.7.3	TRANSFER ROLLER UNIT.....	6-55
	Transfer from the belt.....	6-55
	Image transfer.....	6-55
	Discharge.....	6-56
	Transfer roller contact.....	6-57
6.8	FUSING.....	6-58
6.8.1	OVERVIEW	6-58
6.8.2	FUSING TEMPERATURE CONTROL.....	6-59
	Machine ready temperature: [B].....	6-60
	Print ready temperature: [C].....	6-60
	Target printing temperature: [D].....	6-60
	First print temperature: [G].....	6-60
	Corrections for Small Paper Sizes (less than A5)	6-61
	Overheat Protection	6-61
6.8.3	DRIVE.....	6-62
6.9	CONTROLLER.....	6-63
6.9.1	OVERVIEW	6-63
6.9.2	BOARD LAYOUT	6-65

PERIPHERALS

PAPER TRAY UNIT (B392)

1. REPLACEMENT AND ADJUSTMENT.....	G392-1
1.1 PAPER FEED UNIT	G392-1
1.2 PAPER FEED MOTOR AND DRIVE BOARD	G392-2
1.2.1 PAPER FEED MOTOR.....	G392-2
1.2.2 DRIVE BOARD.....	G392-2
1.3 PAPER FEED CLUTCH.....	G392-3
1.4 SENSORS.....	G392-4
1.4.1 PAPER END, PAPER NEAR END, AND PAPER FEED SENSORS.....	G392-4
Paper feed sensor.....	G392-4
Paper end and paper near end sensors.....	G392-4
1.4.2 PAPER SIZE DETECTION SWITCH.....	G392-4
1.5 PAPER FEED ROLLER	G392-5
1.6 FRICTION PAD	G392-5
2. DETAILED DESCRIPTIONS	G392-6
2.1 OVERALL MACHINE INFORMATION	G392-6
2.1.1 MECHANICAL COMPONENT LAYOUT.....	G392-6
2.1.2 ELECTRICAL COMPONENT LAYOUT	G392-7
2.2 DETAILED DESCRIPTIONS.....	G392-8
2.2.1 PAPER FEED AND SEPARATION	G392-8
2.2.2 PAPER LIFT	G392-9
2.2.3 PAPER NEAR-END/END DETECTION.....	G392-10
Paper near end detection.....	G392-10
Paper end detection.....	G392-10
2.2.4 PAPER SIZE DETECTION.....	G392-11

SPECIFICATIONS

1. GENERAL SPECIFICATIONS.....	SPEC-1
2. SUPPORTED PAPER SIZES.....	SPEC-3
3. SOFTWARE ACCESSORIES	SPEC-4
3.1 PRINTER DRIVERS.....	SPEC-4
3.2 UTILITY SOFTWARE	SPEC-4
4. MACHINE CONFIGURATION.....	SPEC-5
5. OPTIONAL EQUIPMENT	SPEC-6

1. INSTALLATION

1.1 INSTALLATION REQUIREMENTS

1.1.1 ENVIRONMENT

1. Temperature Range: 10°C to 32°C (50°F to 89.6°F)
2. Humidity Range: 15% to 80% RH
3. Ambient Illumination: Less than 2,000 lux (do not expose to direct sunlight)
4. Ventilation: 3 times/hr/person
5. Do not put the machine in areas that get sudden temperature changes. This includes:
 - 1) Areas directly exposed to cool air from an air conditioner.
 - 2) Areas directly exposed to heat from a heater.
6. Do not put the machine in areas that get exposed to corrosive gas.
7. Do not install the machine at locations over 2,500 m (8,125 ft.) above sea level.
8. Put the machine on a strong, level bottom. (Inclination on any side must be no more than 5 mm.)
9. Do not put the machine in areas with strong vibrations.

1.1.2 MACHINE LEVEL

Front to back: Within 5 mm (0.2") of level

Right to left: Within 5 mm (0.2") of level

1.1.3 MACHINE SPACE REQUIREMENT

Put the machine near the power source with these clearances:

- Left side: Over 50 cm (19.7")
- Rear: Over 10 cm (4")
- Right side: Over 10 cm (4")
- Front: Over 70 cm (27.6")

1.1.4 POWER REQUIREMENTS

⚠ CAUTION

- 1. Make sure that the plug is tightly in the outlet.**
- 2. Avoid multi-wiring.**
- 3. Make sure that you ground the machine.**

1. Input voltage level: 120 V, 60 Hz: More than 11 A (for North America)
220 V to 240 V, 50 Hz/60 Hz: More than 6 A (for Europe/
Asia)
2. Permitted voltage fluctuation: $\pm 10\%$
3. Do not set anything on the power cord.

1.2 MACHINE INSTALLATION

1.2.1 UNPACKING

1. Open the left cover [A] of the printer.

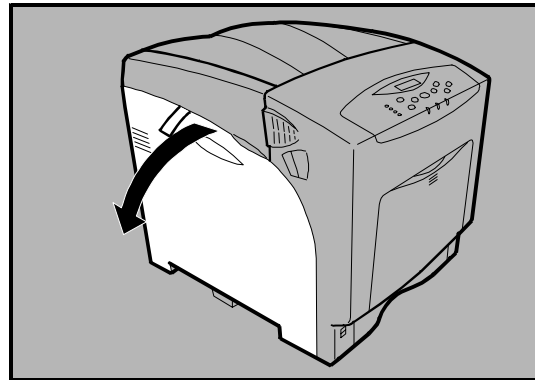

G1051903.WMF

2. Turn the green lever counterclockwise. Then slowly open the drum positioning plate.

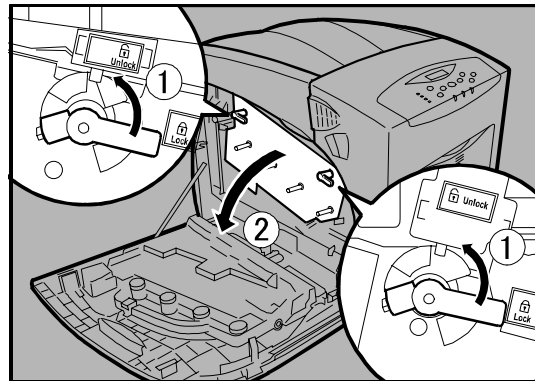

G1051901.WMF

3. Remove the end of the tape from the printer.
4. Slowly pull out the eight pieces of tape protruding from PCU in a horizontal direction.
5. Close the drum positioning plate. Push the green lever ① to lock the drum positioning plate. Then turn it clockwise ②.

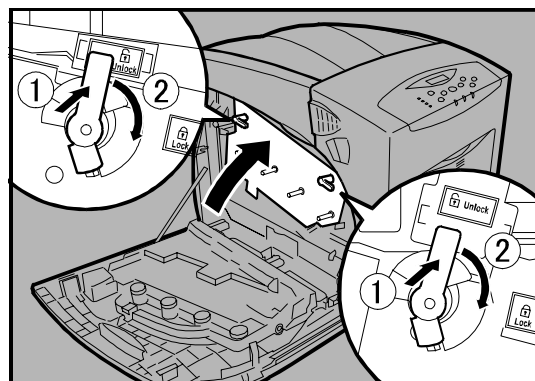

G1051902.WMF

6. Close the left cover.

7. Open the top cover by grasping the handles on the left and right sides.

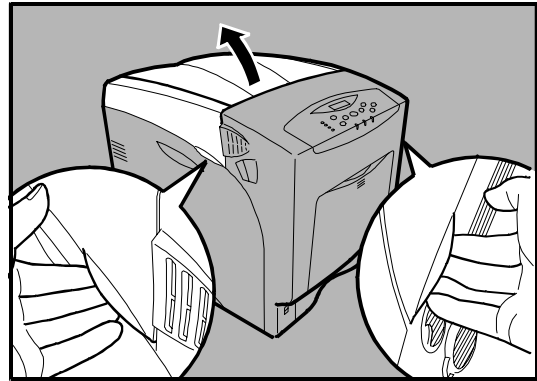

G1051900.WMF

8. Remove the clip that prevents damage to the mouth of the toner hopper (one clip for each of the four toner hoppers).

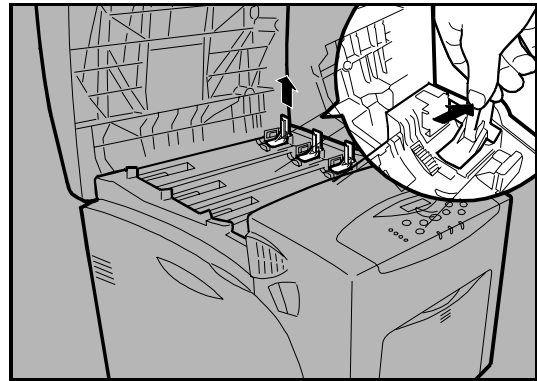

G1051906.WMF

9. Close the top cover.
10. Put labels "1" on the front of the paper tray.

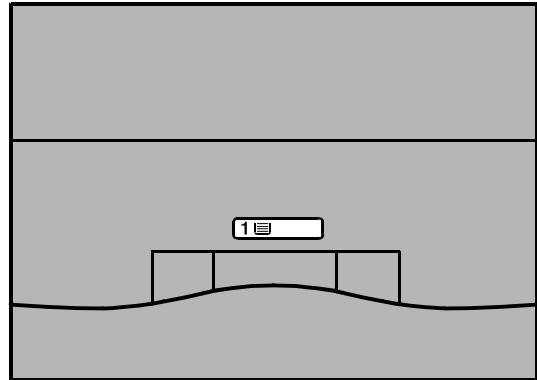

G1051908.WMF

11. Attach the supplied sticker (stating you cannot use paper for an ink-jet printer with this printer) at the front of the machine.

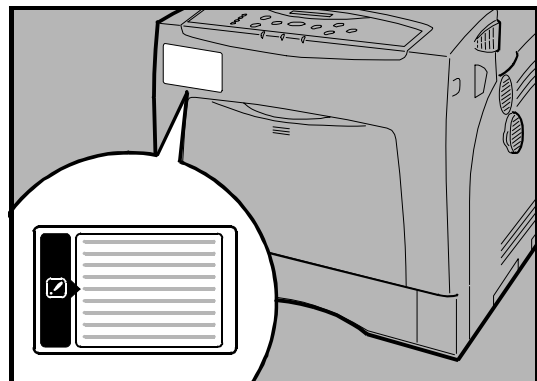

G1051907.WMF

1.2.2 INSTALLING THE TONER BOTTLE

1. Open the top cover [A].

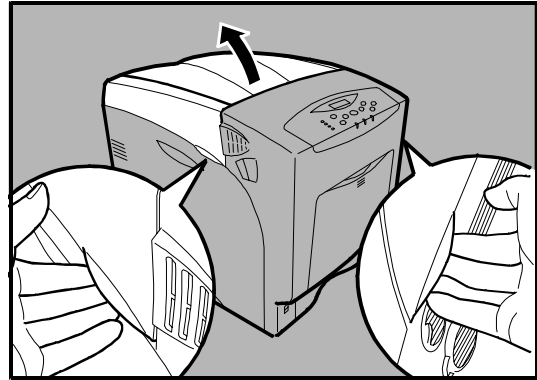

G1051900.WMF

2. Remove the toner bottles from the box.

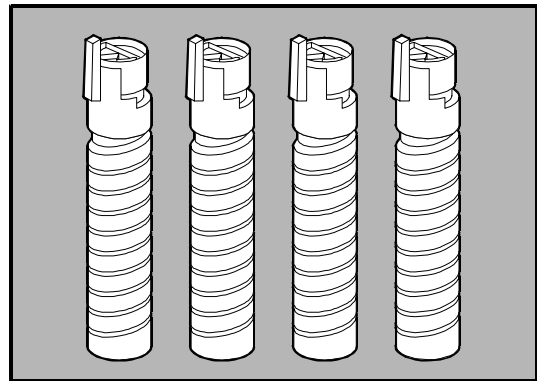

G1051914.WMF

3. Shake the toner bottle up and down seven or eight times.

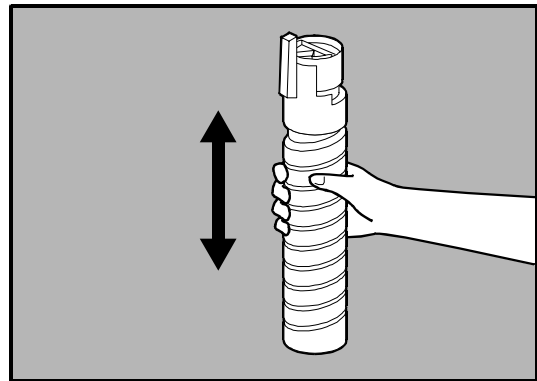

G1051915.WMF

4. Remove the tape from the toner bottle.

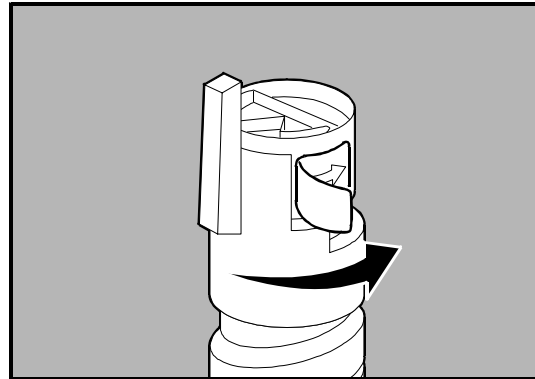

G105I916.WMF

5. Install the yellow toner bottle first. Hold the toner bottle in the horizontal position ① with the locking lever on the top side. Install the toner bottle bottom first. Then move the locking lever to the triangular mark position ②.

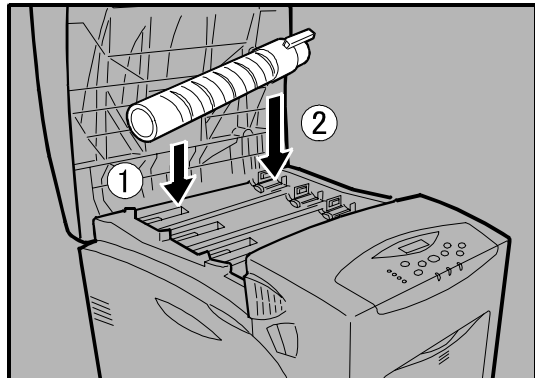

G105I917.WMF

6. Turn the fixing lever to adjust it to the position of the circular mark. Continue to press the fixing lever toward the printer until it rotates smoothly into its position.

NOTE: Do not insert and remove toner bottles again and again. This causes toner leakage.

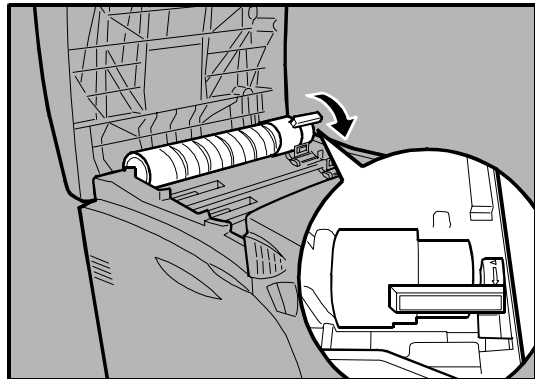

G105I918.WMF

7. Do the same procedures again to insert the other three bottles: cyan (C), magenta (M), and black (K).

8. Close the top cover.

1.2.3 LOADING PAPER

CAUTION: Be careful not to pull the paper tray with too much force when you remove it from the machine. This can let the tray fall and cause personal injury.

1. Pull the paper tray [A] out of the printer until it stops. Then tilt slightly, and pull it out. Put it on a flat surface.
NOTE: You cannot pull tray 1 out if the by-pass tray is open.

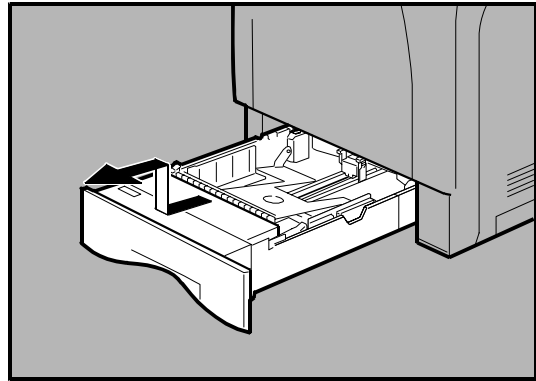

G1051909.WMF

2. Adjust the green clips of the side guide and the end guide to the paper size you want.

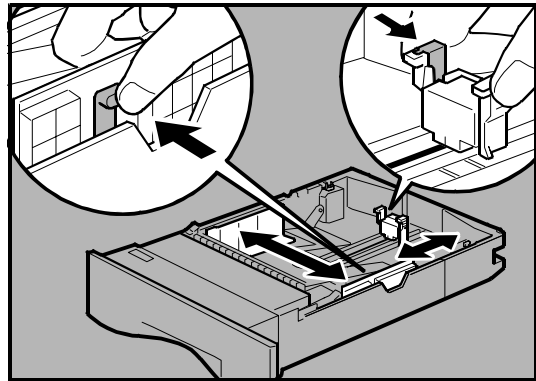

G1051910.WMF

3. Move the green switch on the front of the tray to match the type of paper you want to load. Move the switch to the left when you load thick paper of 75 g/m² or more.

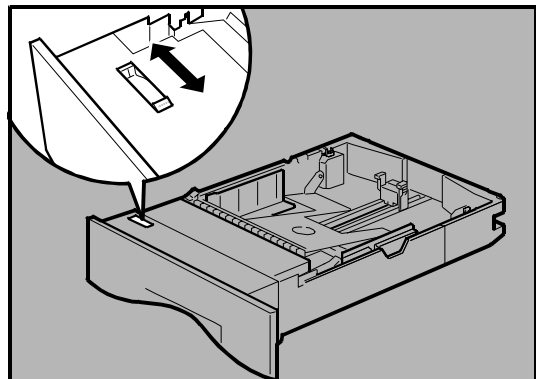

G1051911.WMF

4. Arrange and load a stack of new paper into the tray with the print side up. Make sure that there is no gap between the paper and the paper guides. Adjust the paper guides to close gaps if necessary.

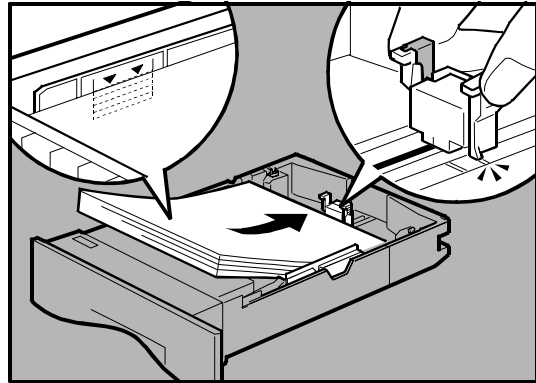

G1051912.WMF

5. Lift the front of the paper tray. Then slowly move the paper tray to the rear until it stops. Set the tray firmly in place to avoid paper jams.

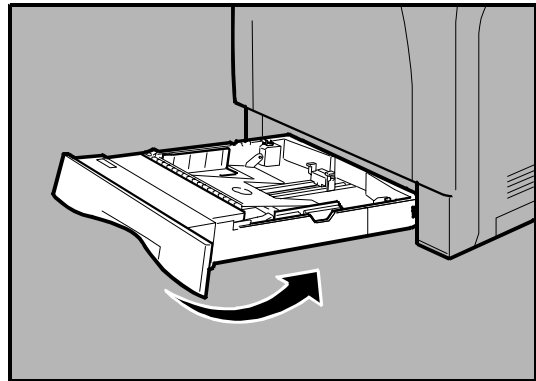

G1051913.WMF

1.2.4 CONNECTING THE POWER CORD

⚠ CAUTION

1. Do not touch the plug with wet hands. This causes electrical shock.
2. When you pull the plug out of the socket, grip the plug, not the cord, to avoid damaging the cord and causing a fire or an electric shock.

Installation

NOTE: 1) Make sure to firmly connect the power plug to the socket outlet.
2) The printer must be off when you connect or disconnect the power cord.

1. Make sure that the power switch is turned off.

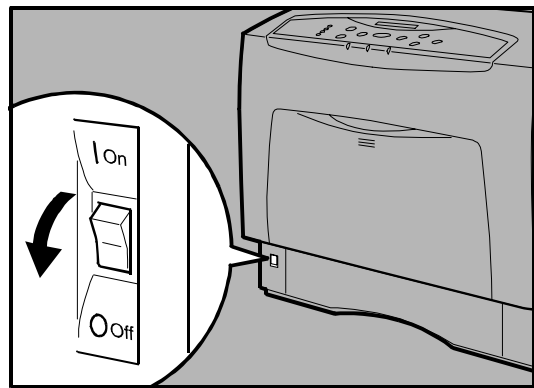

G1051904.WMF

2. Plug in the power cord.

3. Turn the power switch on.

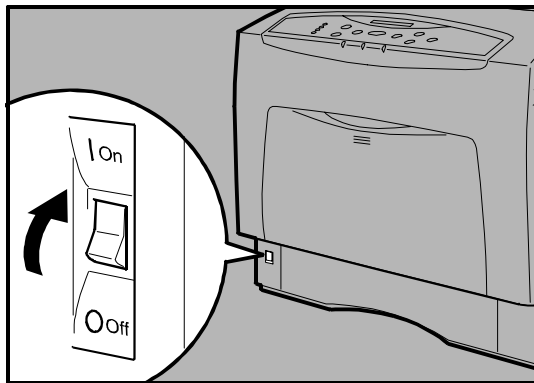

G1051905.WMF

NOTE: 1) It can take a few minutes after the main power comes on before you can use the machine.
2) Do not turn off the power switch at the time "Loading Toner..." shows on the display. This prevents malfunction.

1.2.5 SELECTING THE PANEL DISPLAY LANGUAGE

NOTE: 1) You can select one of these languages (the default is English): English, German, French, Italian, Dutch, Swedish, Norwegian, Danish, Spanish, Finnish, Portuguese, Czech, Polish or Hungarian.

2) You do not have to do this procedure if you use the English. Do this procedure if you want to use a different language.

1. Turn on the printer.
NOTE: "Ready" shows on the panel display after the machine warms up.
2. Press the Menu key.
NOTE: "Menu" shows on the panel display.
3. Press the "▲" or "▼" key to show "Language."
4. Press the Enter key. "Language: *English" shows on the panel display.
5. Press the "▲" or "▼" key to get the language you want.
6. Press the Enter key. "Menu" shows on the panel display.
7. Press the On Line key. "Ready" shows on the panel display.

1.2.6 PRINTING THE TEST PAGE

NOTE: You can check if the printer works correctly by printing a test page such as the configuration page. However, you cannot check the connection between the printer and the computer by printing the test page.

1. Turn on the printer.
NOTE: "Ready" shows on the panel display after the machine warms up.
2. Press the Menu key.
3. Press the "▲" or "▼" key to get "List/Test Print."
4. Press the Enter key. "List/Test Print Config. Page" shows on the panel display.
5. Make sure that "Config. Page" is on the display. Then press the Enter key.
6. The test printing starts shortly after.
7. Press the "On Line" key. "Ready" shows on the panel display.
8. Turn off the printer's power switch.

1.3 OPTIONAL UNIT INSTALLATION

These options are available for this machine. Refer to the Operating Instructions for how to install these options:

- Paper Tray Unit (G392).
- Hard disk for G104 (G395)
- IEEE802.11b interface (Wireless LAN: G813)
- IEEE1394 interface (B581)
- IEEE 1284 interface (B679)
- Bluetooth interface (B736)
- 128 MB DIMM (B584)
- 256 MB DIMM (G818)
- NVRAM (User account enhancement: G395)

1.4 METER CHARGE

Change these SP modes settings if the customer has a service contract. The settings depend on the contract type.

Item	SP No.	Function	Default
Meter charge	SP 5930 1	<p>Specifies whether the meter charge mode is enabled or disabled.</p> <p>Meter charge mode enabled:</p> <ul style="list-style-type: none"> • The Counter menu shows immediately after the Menu key is pressed. • The counter type selected by the counting method (SP5-045-1) can be displayed with the Counter menu. • The counter values can also be printed with the Counter menu. • The PM warning is not shown when the replacement time arrives. <p>Meter charge mode disabled:</p> <ul style="list-style-type: none"> • The Counter menu is not shown. 	Off
Counting method	SP 5045 1	Specifies whether the counting method used in meter charge mode is based on developments or prints.	Prints
Fax No. Setting	SP 5812 2	<p>Programs the service station fax number.</p> <p>The number is printed on the counter list when the meter charge mode is selected. This lets the user fax the counter data to the service provider.</p>	

NOTE: 1) The default setting for this machine is meter-charge mode off.
2) You cannot reset the meter-charge counter.

1.5 TRAY HEATER

1. Electrical boards unit [A] (☛ 3.2)
2. Rear cover [B]
3. Rear cover piece [C] for the power supply connector
4. Decal [D]
5. Decal [E]

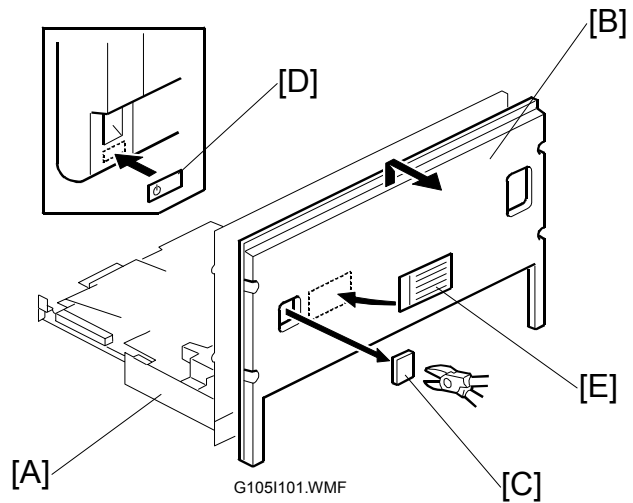

6. Harness [F] (☛ x 2, ☛ x 3)
 7. Tray heater switch [G]
 8. Tray heater [H] (☛ x 2, ☛ x 1)
- NOTE:** You can adjust the tray heater switch setting as the below table shows with SP5953-001.

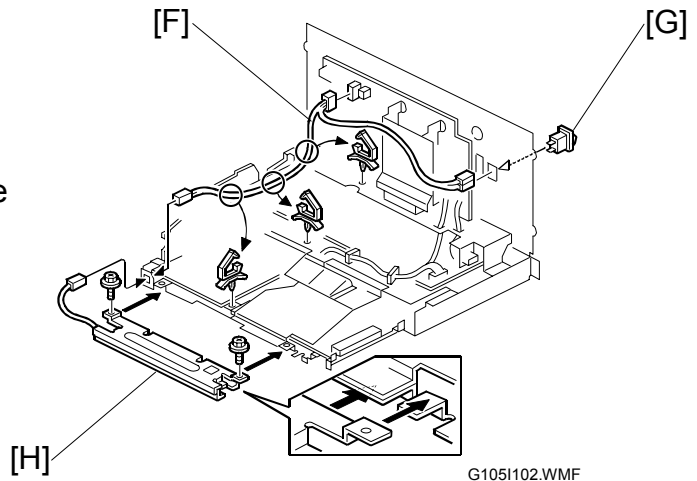

SP5953-001	Tray heater switch	When the Main Power turns on	When the printer is in energy saver mode
0: Off	On	No power supply	Power supply
	Off	No power supply	No power supply
1: On	On	Power supply	Power supply
	Off	No power supply	No power supply

2. PREVENTATIVE MAINTENANCE

2.1 USER REPLACEABLE ITEMS

The user replaces these items if the service contract requires that the user does some of the PM.

Item	Remarks
PCU	50 K (YMC, BK)
Transfer Belt Unit	100 K
Waste Toner Bottle	50 K
Maintenance Kit - Fusing Unit - Transfer Roller - Paper Feed Roller x 3 - Friction Pad x 3 - Dust Filter x 2	100 K

Preventive Maintenance

Chart: A4 (LT), 5%

Mode: Continuously Printing

Environment: Recommended temperature and humidity

Yield changes depend on circumstances and print conditions

An error message shows when a maintenance counter gets to the value in the PM table when the machine's default settings are used.

It is not necessary to reset counters for each part if the technician does the PM. The machine detects new components automatically and resets the necessary counters.

2.2 SERVICE MAINTENANCE

2.2.1 RECOMMENDED CLEANING PROCEDURE

1. Turn off the main switch.
2. Remove the waste toner bottle.
3. Remove the PCUs.
4. Remove the transfer belt unit. Do not touch the transfer belt surface.
5. Remove the fusing unit.
6. Remove the standard paper tray.
7. Clean the paper path.
8. Clean all printer rollers with dry cloth only. **Do not clean the transfer roller.**
9. Use a blower brush to clean the laser unit windows.
10. Vacuum the interior of the printer.
11. Carefully clean the area around the transfer roller.

3. REPLACEMENT AND ADJUSTMENT

CAUTION

Turn off the main power switch and unplug the machine before you do the procedures in this section.

Important: Remove these before you do the procedures in this section:

- 4 toner bottles (cyan, magenta, yellow, and black)
- Waste toner bottle
- Standard paper tray

3.1 SPECIAL TOOLS AND LUBRICANTS

3.1.1 TOOLS

Item	Part Number	Description	Q'ty
1	G0219350	Loop Back Connector: Parallel: Bi-direct	1
2	A0299387	Digital Multimeter –FLUKE87	1
3	B6455010	SD Card	1
4	B6456700	PCMCIA Card Adapter	1
5	B6456800	USB Reader/ Writer	1
6	C4019503	20X Magnification Scope	1

3.2 ELECTRICAL COMPONENTS

- NOTE:** 1) Before you replace the EGB (Engine Board), the controller, or the NVRAM, print out the SMC reports (“SP Mode Data” and “Logging Data”).
- 2) After you replace the EGB (Engine Board) or the controller, remove the NVRAM from the old board and install it on the new board. If the NVRAM on the old board is defective, replace the NVRAM (☛ 3.2.8).

3.2.1 ELECTRICAL BOARD UNIT

1. Front door
2. Top cover
3. Right cover [A] (⚙ x 1)

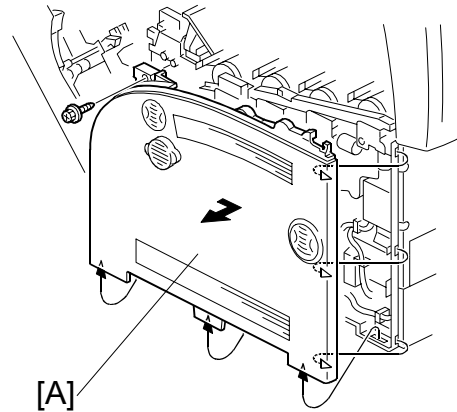

G 105R101.WMF

4. Color development motor unit [B] (⚙ x 3, ⚙ x 1)

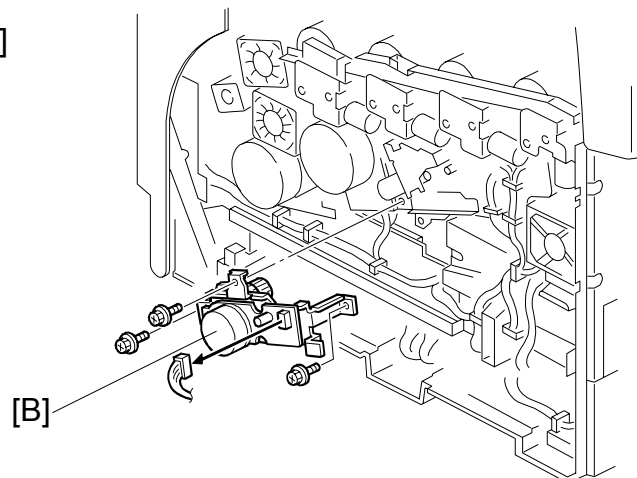

G 105R102.WMF

5. Side bar [C] (⚙ x 4)
6. IOB (Input/Output Board) [D] (⚙ x 2, ⚙ x 3)
7. ⚙ [E] x 1

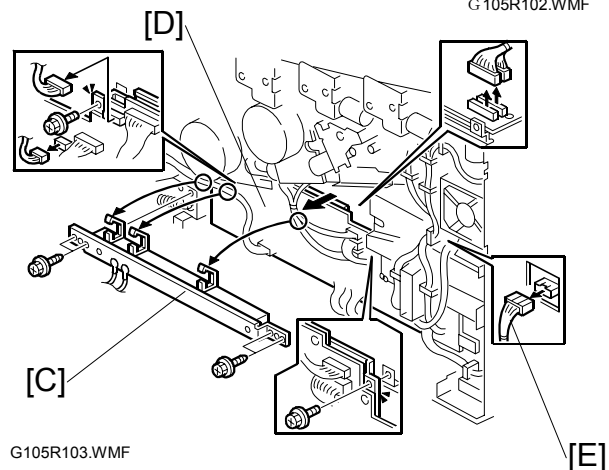

G105R103.WMF

- 8. Left cover [A]
- 9. Drum positioning plate [B]
- 10. Drum positioning plate belt [C] (⚙️ x 1)
- 11. ⚙️ [D] x 3, ⚙️ [E] x 1

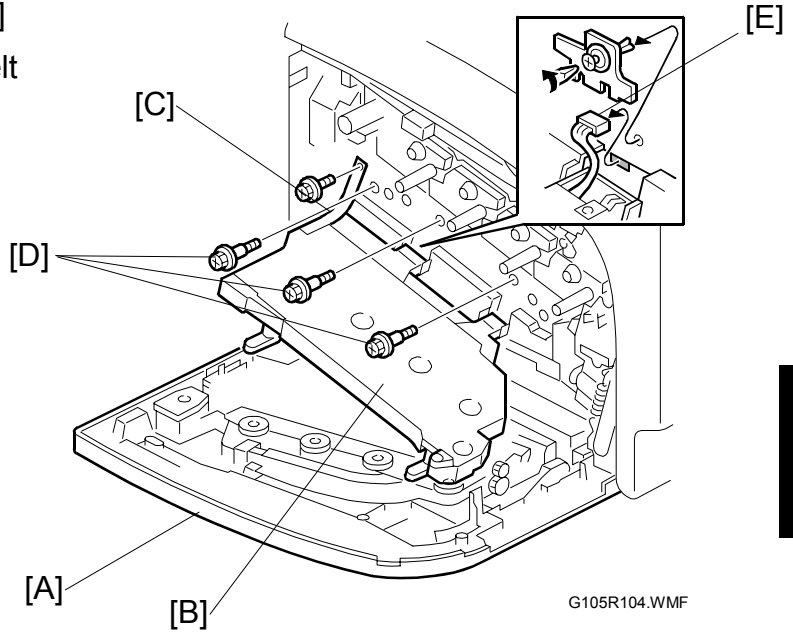

Replacement
Adjustment

- 12. Electrical board unit [F] (⚙️ x 4, ⚙️ x 2)

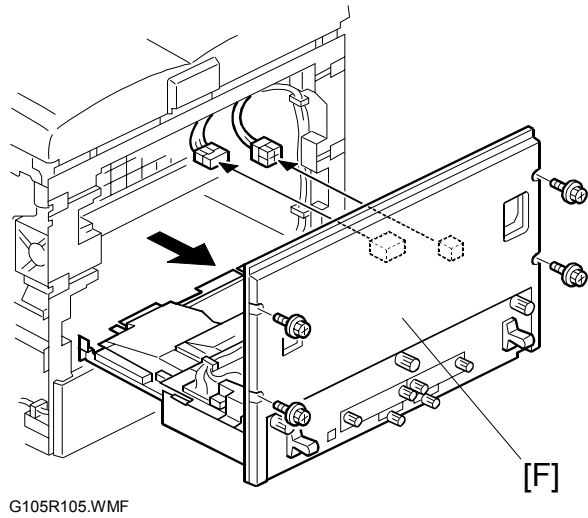

3.2.2 IOB (INPUT/OUTPUT BOARD)

1. Front door
2. Top cover
3. Right cover (☛ 3.2.1)
4. Side bar (☛ 3.2.1)
5. IOB [A] (⚙ x 2, 🛠 x all)

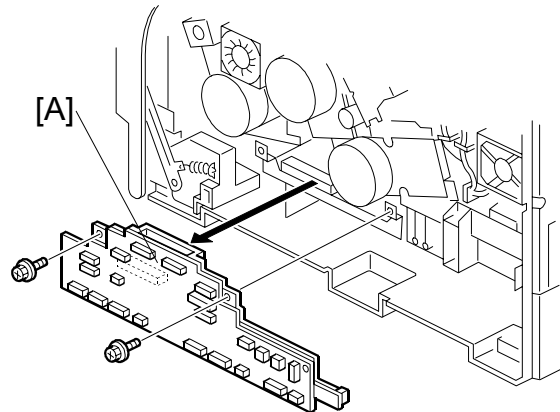

G105R133.WMF

3.2.3 CONTROLLER BOARD

1. Controller unit [A] (⚙ x 3)

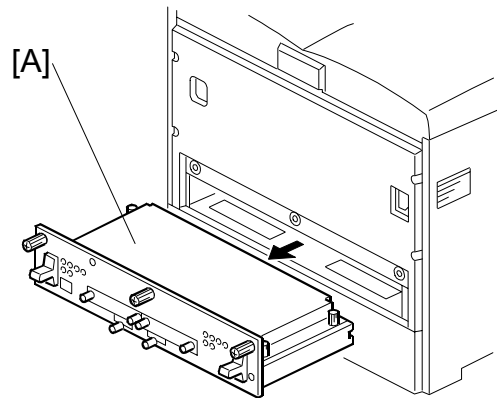

G105R111.WMF

2. Controller unit cover [B] (⚙ x 4)

3. Controller board [C] (⚙ x 7)

NOTE: Remove the NVRAM from the old board. Then install it on the new board.

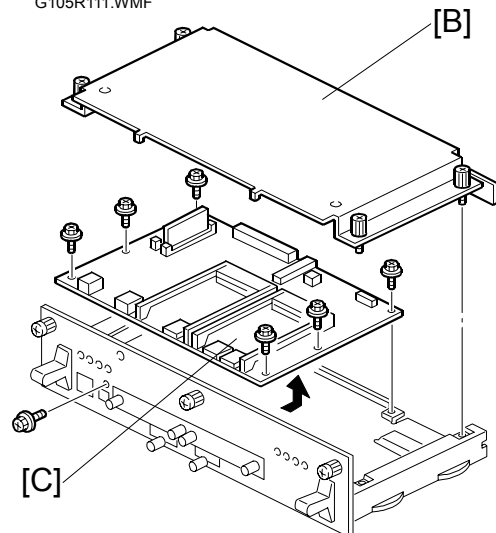

G105R135.WMF

- CAUTION:**
- 1) Keep NVRAMs away from objects that can cause static electricity. The data in NVRAMs can be corrupted by static electricity.
 - 2) Make sure the NVRAM is correctly installed on the board. A half-disk is engraved on one side of the NVRAM, and a guide mark is on one side of the NVRAM slot. When you install the NVRAM, the half-disk and the guide mark must be on the same side.

3.2.4 PSU (POWER SUPPLY UNIT) BOARD

1. Electrical boards unit (☞ 3.2.1)
2. PSU board [A] (⚙ x 6, 📏 x 5)

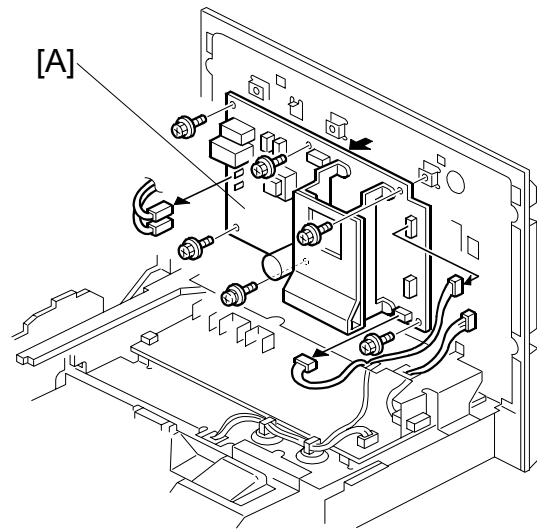

G105R136.WMF

3.2.5 HIGH VOLTAGE POWER SUPPLY BOARD 1

1. Electrical boards unit (☞ 3.2.1)
2. PSU board (☞ 3.2.4)
3. Electrical board unit frame [A] (⚙ x 4)
4. High voltage terminal plate [B] (⚙ x 1)
5. High voltage power supply board 1 [C] (⚙ x 4, 📏 x 4, stand offs x 2)

NOTE: Make sure that each high voltage terminal is connected securely after you replace this board.

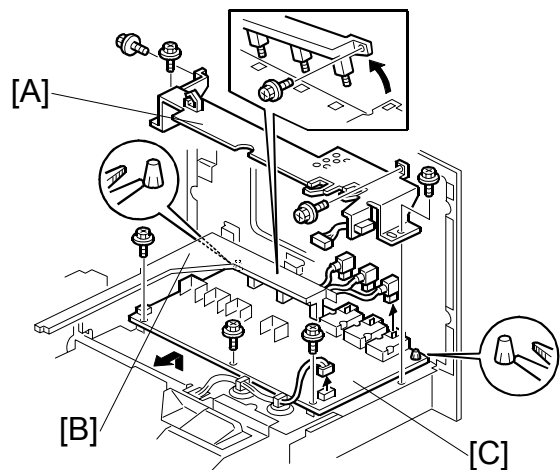

G105R137.WMF

3.2.6 EGB (ENGINE BOARD) AND HIGH VOLTAGE POWER SUPPLY BOARD 2

1. Electrical board unit (☛ 3.2.1)
2. EGB shield [A] (🔩 x 3, 📏 x 1)
3. EGB [B] (🔩 x 4, 📏 x 4)
NOTE: Remove the NVRAM from the old board. Then install it on the new board.
4. High voltage terminal plate [C] (🔩 x 1)
5. High voltage power supply board 2 [D] (🔩 x 3, 📏 x 2)
NOTE: Make sure that each high voltage terminal is connected securely after you replace this board.

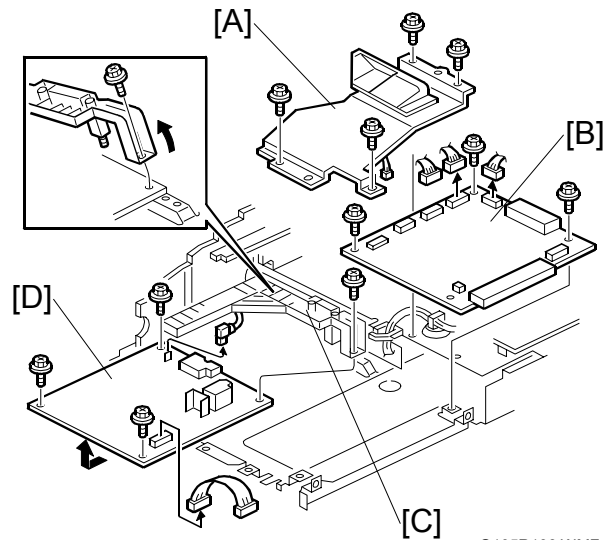

- CAUTION:**
- 1) Keep NVRAMs away from objects that can cause static electricity. The data in NVRAMs can be corrupted by static electricity.
 - 2) Make sure the NVRAM is correctly installed on the board. A half-disk is engraved on one side of the NVRAM, and a guide mark is on one side of the NVRAM slot. When you install the NVRAM, the half-disk and the guide mark must be on the same side.

3.2.7 LCD PANEL

1. LCD panel [A] (📏 x 1)

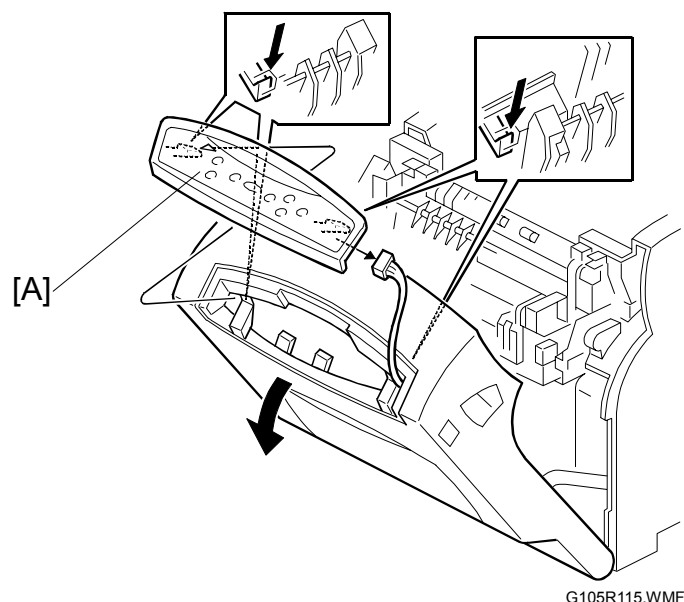

3.2.8 NVRAM REPLACEMENT PROCEDURE

Make sure that you have the SMC report (factory settings) before beginning the following procedure.

NVRAM on the EGB (Engine Board)

For this procedure, you must know the device number and the destination code (☛ step 10).

1. Start the SP mode.
2. Use SP5-990 to print out the SMC reports (“SP Mode Data” and “Logging Data”) if possible.
3. Turn off the main power switch and unplug the power cord.
4. Replace the NVRAM on the EGB and reassemble the machine.
5. Plug in the power cord.
6. Turn on the main power switch.
7. Start the SP mode.
8. Contact your supervisor to enter the machine’s device number.
NOTE: SC542 may be displayed until the machine’s device number and destination code are programmed properly.
9. Turn the main power switch off and on.
10. Start the SP mode.
11. Use SP5-801-002 to reset the engine settings.
12. Reset the meter charge settings (SP5-930-001).
13. Enter the SP mode changes previously made at the factory and the field.
14. Replace all maintenance kits with new ones.

NVRAM on the Controller

1. Start the SP mode.
2. Use SP5-990 to print out the SMC reports (“SP Mode Data” and “Logging Data”) if possible.
3. Use SP5-824 to upload the NVRAM data if possible.
4. Turn off the main power switch and unplug the power cord.
5. Replace the NVRAM on the controller and reassemble the machine.
6. Plug in the power cord.
7. Turn on the main power switch.
8. Start the SP mode.
9. Use SP5-825 to download the NVRAM data if possible. If it can be done, the following steps are not required.
10. Use Memory Clear (SP5-801) to reset this data:
 - SCS (SP5-801-003)
 - PRT (SP5-801-008)
 - NCS (SP5-801-011)
11. Do Counter Clear (SP7-810).
12. Make these contract-related settings:
 - Counter Method (SP5-045)
 - Telephone Number Setting > Fax Telephone Number (SP5-812-002) if the meter charge mode (SP5-930-001) is “ON” (enabled)
13. Enter the SP mode changes previously made at the factory and the field.

NVRAMs on the EGB and Controller

For this procedure, you must know the device number and the destination code (☛ step 10).

1. Start the SP mode.
2. Use SP5-990 to print out the SMC reports (“SP Mode Data” and “Logging Data”) if possible.
3. Use SP5-824 to upload the NVRAM data if possible.
4. Turn off the main power switch and unplug the power cord.
5. Replace the NVRAMs on the EGB and the controller, and reassemble the machine.
6. Plug in the power cord.
7. Turn on the main power switch.
8. Start the SP mode.
9. Use SP5-825 to download the NVRAM data if possible.
10. Contact your supervisor to enter the machine’s device number.
NOTE: SC542 may be displayed until the machine’s device number and destination code is programmed properly.
11. Turn the main power switch off and on.
12. Start the SP mode.
13. Use SP5-801-002 to reset the engine settings.
14. Use Memory Clear (SP5-801) to reset this data:
 - SCS (SP5-801-003)
 - PRT (SP5-801-008)
 - NCS (SP5-801-011)
15. Do Counter Clear (SP7-810).
16. Reset the meter charge settings (SP5-930-001).
17. Make these contract-related settings:
 - Counter Method (SP5-045)
 - Telephone Number Setting > Fax Telephone Number (SP5-812-002)
18. Enter the SP mode changes previously made at the factory and the field.
19. Replace all maintenance kits with new ones.

3.3 LASER OPTICS

WARNING

Turn off the main power switch and unplug the printer before you do the procedures in this section. Laser beams can cause serious eye injury.

3.3.1 CAUTION DECAL LOCATIONS

Caution decal is attached as shown below

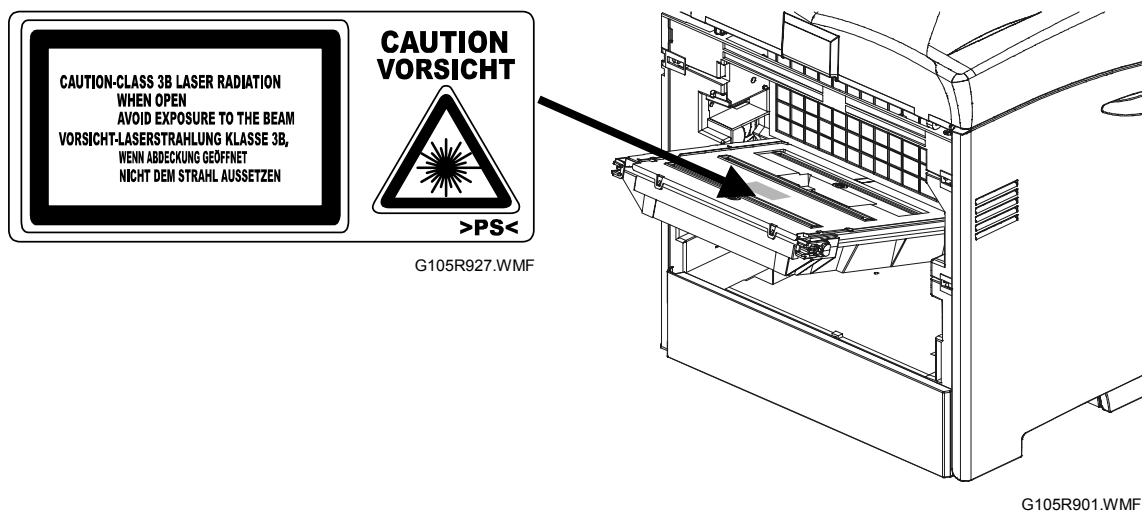

WARNING

Make sure to turn off the main power switch and disconnect the power plug from the power outlet before you do any disassembly or adjustment of the laser unit. This printer uses a class 3B laser beam with a wavelength of 655 nm and an output of 7 mW. The laser can cause serious eye injury.

3.3.2 LD UNIT

1. Electrical boards unit (☛3.2.1)
2. LDU [A]

NOTE: Print the SMC report with SP 5990-002 before you replace the LDU.

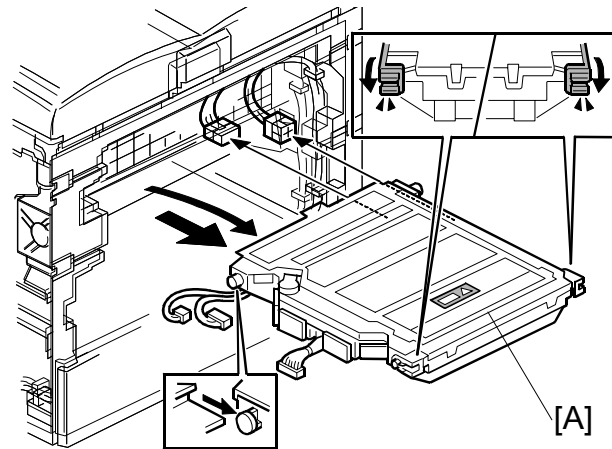

G105R106.WMF

Color registration adjustment

NOTE: You must manually do the color registration adjustment after you install the new LDU.

Do these steps.

When the polygon mirror motor or LDB unit is defective, only replace the defective parts. At this time, if only the motor is changed it is not necessary to do this adjustment procedure.

1. Print the SMC report with SP 5990 2 before you replace the LDU. Find the values for SP 2181 1, SP 2181 11, 2181 21, and 2181 31.
2. Do SP 2111 2 (Pro. Position Adj > Execute) to roughly adjust the line position after you install the new LDU. "Result = OK" shows on the LCD if this is done correctly. If not, do it again until you get "OK".
3. Do SP2111 3 (Skew Adjust. > Execute) to measure the skew values for each color. "Result = OK" shows on the LCD if this is done correctly. If not, do it again until you get "OK".
4. Check the skew values with SP 2181: Then write down the values. (You can also check these if you print the SMC report again with SP 5990 2. The values will probably be different from the values on the report that you printed in step 1.)
 - SP 2181 1 for black skew
 - SP 2181 11 for magenta
 - SP 2181 21 for cyan
 - SP 2181 31 for yellow

5. Open the left cover
6. Adjust the skew adjustment cam [A] for each color with a screwdriver. You must adjust the skew values for each color until they are all the same as the value for magenta that you found in step 1, before you replaced the LDU. Example, if the new value for K (after step 4) is -300 and the old value for magenta (in step 1) is -250, you must adjust the skew for K until it is -250.

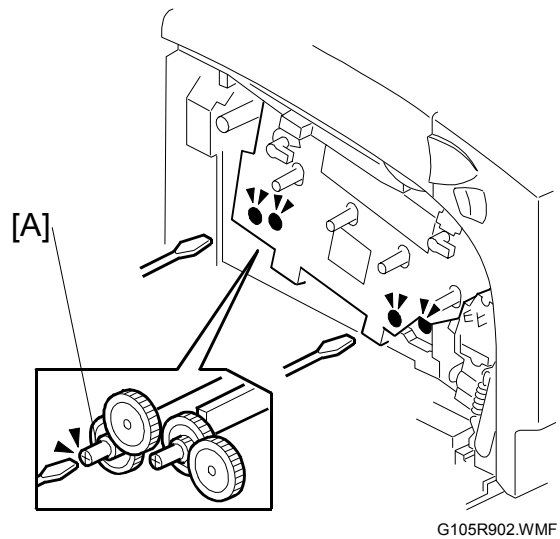

G105R902.WMF

Turn the cam as shown in the “Cam Rotation Direction” column below to increase the skew value.

Turn it in the opposite direction from this to decrease the skew value.

“Adjustment value” shows the change when you turn the cam one click.

Color	Cam Rotation Direction	Adjustment value
Yellow	CW	14 μm
Cyan	CW	8 μm
Magenta	CCW	7 μm
Black	CCW	10 μm

NOTE: The adjustment values in the table are not exact values. These are approximate values.

CW: Clockwise, CCW: Counter-clockwise

The diagram shows the effect on line skew [B] when you turn the cam in a counter clockwise direction.

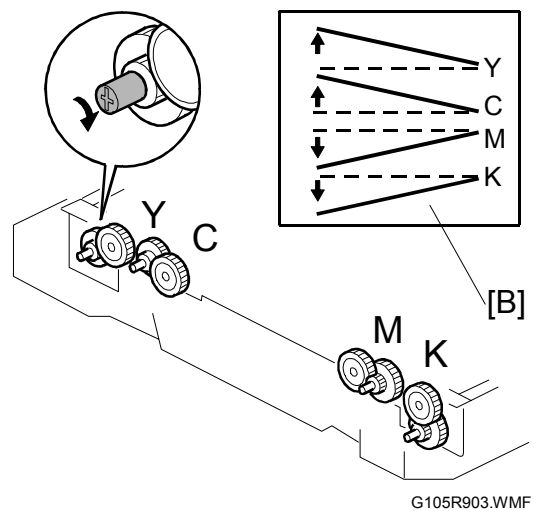

G105R903.WMF

7. Close the left cover. Then measure the skew values again with SP 2111 3. (To do this, repeat step 3.) If these are close to the value for magenta that you found in step 1 (within one click in the above table), go to the next step. If not, do SP 2111 3 again until you get a good result.
8. Do SP 2111 1 to finely adjust the line position for each color. Try SP 2111 2 if “Result = OK” does not show.
9. When you get “Result = OK”, this adjustment is completed.

3.3.3 LDB

1. LDU (☞ 3.3.2)
2. LDB [A] (☞ x 2)

NOTE: Make sure that the spring plate [B] holds the LDB unit.

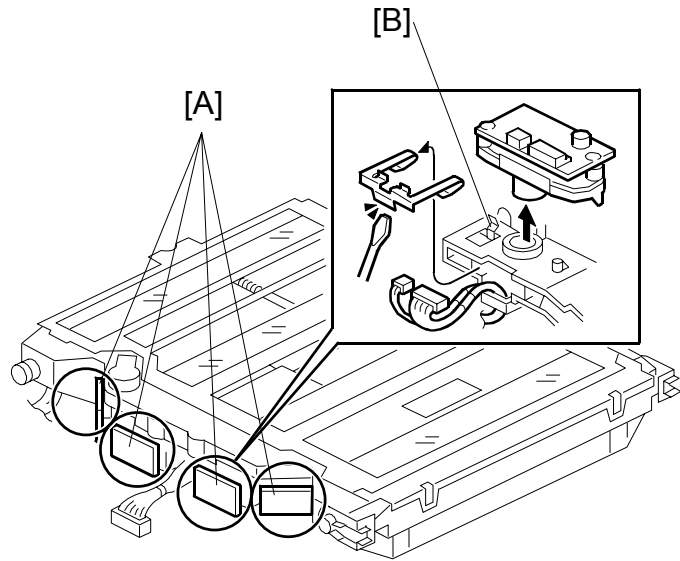

G105R107.WMF

Replacement
Adjustment

3.3.4 POLYGON MIRROR MOTOR

1. LDU (☞ 3.3.2)
2. Top cover [A] (☞ x 5, tabs x 4)

NOTE: Do not touch the mirrors.
Clean with an optics cloth if you touch the mirrors.

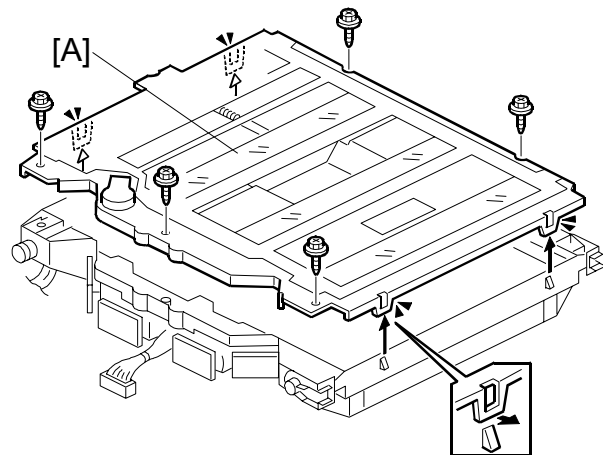

G105R108.WMF

3. Polygon motor cover [B] (☞ x 3), shading plate [C], sponge [D]
4. Polygon mirror motor [E] (☞ x 4), drive board [F] (☞ x 2, ☞ x 1, 1 flat cable)

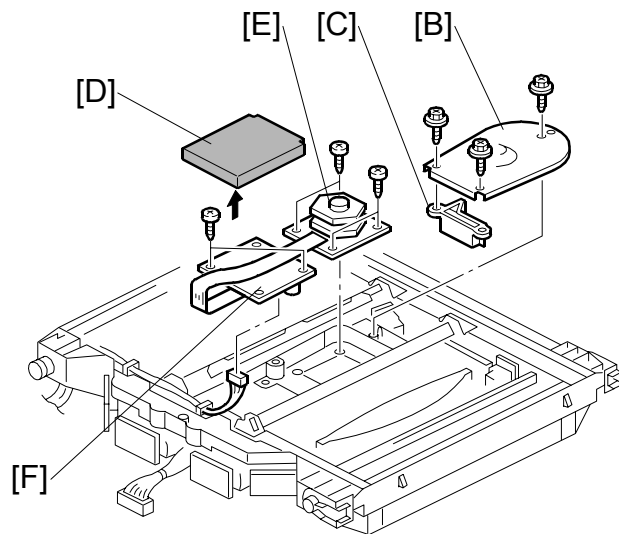

G105R109.WMF

3.3.5 LASER SYNCHRONIZING DETECTOR BOARDS

1. LDU (☛ 3.3.2)
2. Top cover
3. Synchronizing detector board unit [A] (🔩 x 1)
4. Synchronizing detector board [B] (🔩 x 1, 📏 x 1)

NOTE: Do not touch the mirrors.
Clean with an optics cloth if you touch the mirrors.

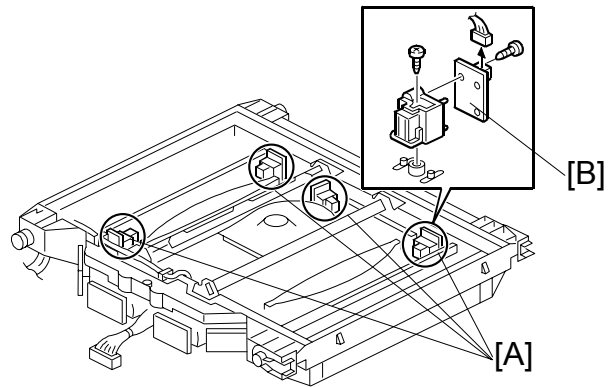

G105R110.WMF

3.3.6 LDU SHUTTER MOTOR UNIT AND SENSOR

1. Electrical boards unit (☛3.2.1)
2. LDU (☛ 3.3.2)
3. LDU shutter motor unit [A] (🔩 x 2, 📏 x 2, 📏 x 1)
4. Slide up the gear [B] (⊕ x1).

NOTE: To do this, place the projection [E] of the gear as shown in the diagram below. The worm gear [F] must turn.

5. LDU shutter sensor [C]
6. LDU shutter motor [D] (🔩 x 2, 📏 x 1)

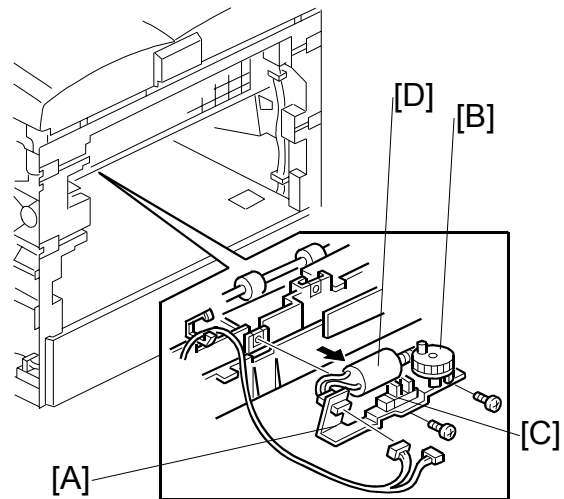

G105R155.WMFF

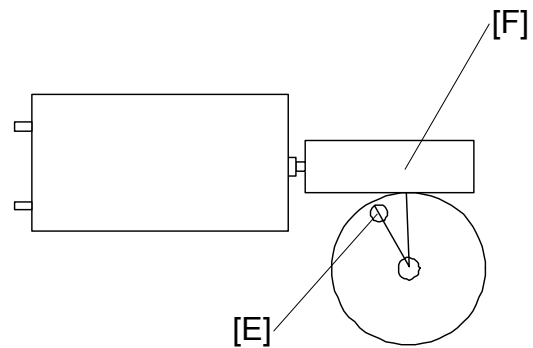

G105R929.WMF

3.4 PAPER FEED

3.4.1 PAPER FEED ROLLER

1. Standard tray [A]

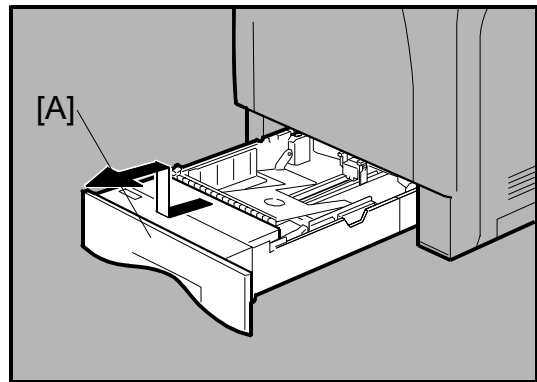

G105R904.WMF

Replacement
Adjustment

2. Slide the side roller holder [B]
3. Paper feed roller [C]

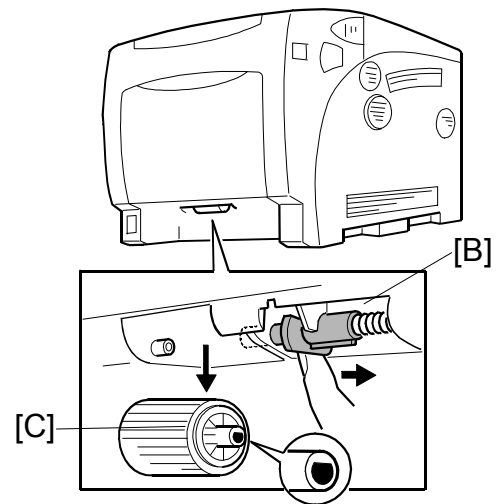

G105R149.WMF

3.4.2 PAPER FRICTION PAD

1. Standard tray (☛ 3.4.1)

2. Paper friction pad [A]

NOTE: Make sure that the paper friction pad stick is put through the spring when you reassemble it.

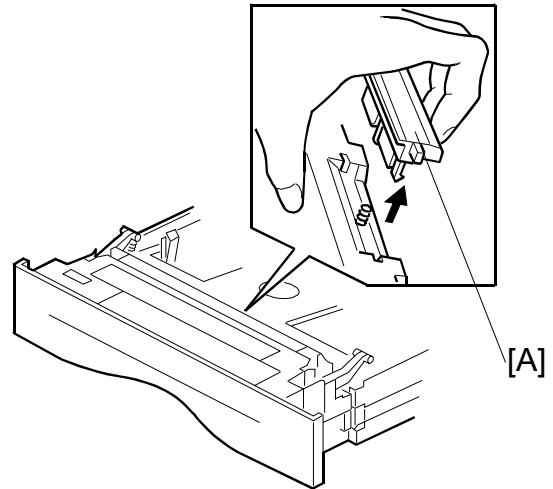

G105R150.WMFF

3.4.3 BY-PASS PAPER SIZE SENSOR

1. By-pass tray cover [A]

2. By-pass paper size sensor [B] (☛ x 1)

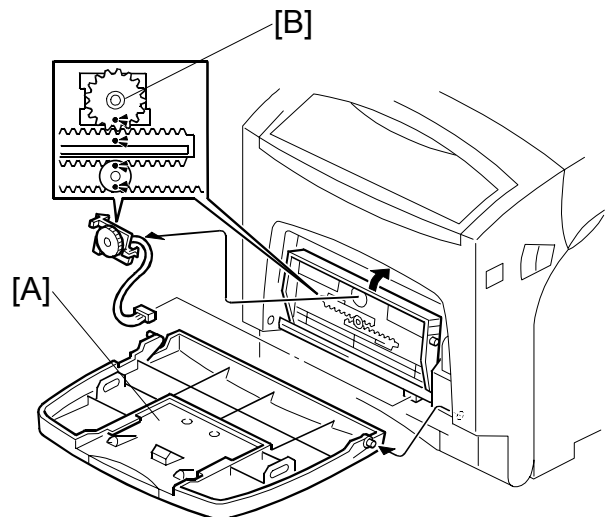

G105R112.WMF

3.4.4 BY-PASS FEED ROLLER, FRICTION PAD

1. By-pass tray cover [A]
2. By-pass tray [B] (⌘ x 2, ≡ x 1) and the harness cover [C]

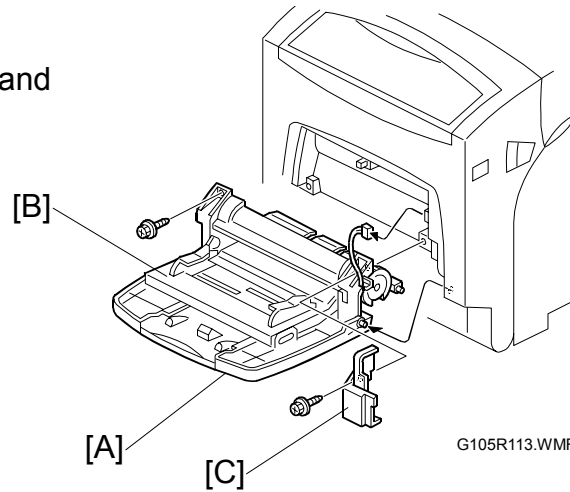

3. By-pass feed shaft cover [D]
4. Move the holding roller left [E]
5. By-pass feed roller [F]

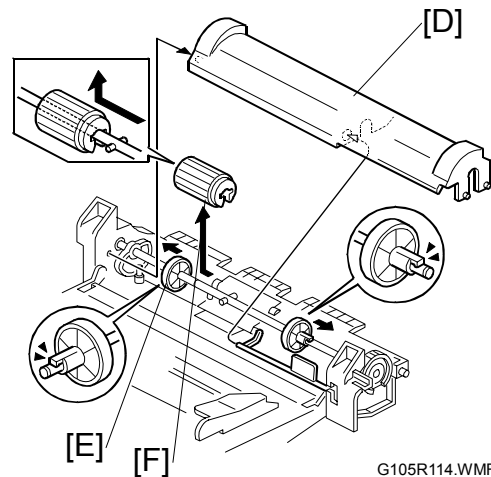

6. By-pass friction pad [G]
 - 1) Pull up the edge of the by-pass friction pad (①).
 - 2) Pull the by-pass friction pad forward. When you do this, hold down the edge where its shaft is located (②).

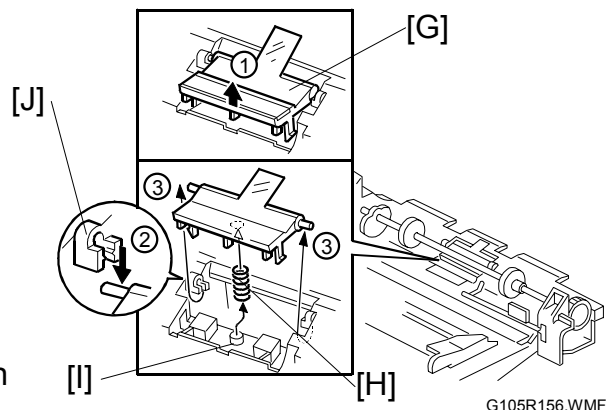

Reassembling the by-pass friction pad

1. Place the spring [H] on the projection [I] of the by-pass tray.
2. Hold down the by-pass friction pad after you put the spring on the projection of pad's reverse side (③).
3. Release the by-pass tray friction pad when it passes through the bushing [J].
4. Pull up the shaft of the by-pass friction pad to the busing until it is clicked.

Replacement Adjustment

3.4.5 REGISTRATION SENSOR

1. Front Door
2. Fusing unit (☛ 3.8.1)
3. Registration guide [A]
4. Registration sensor [B] (☛ x 1)

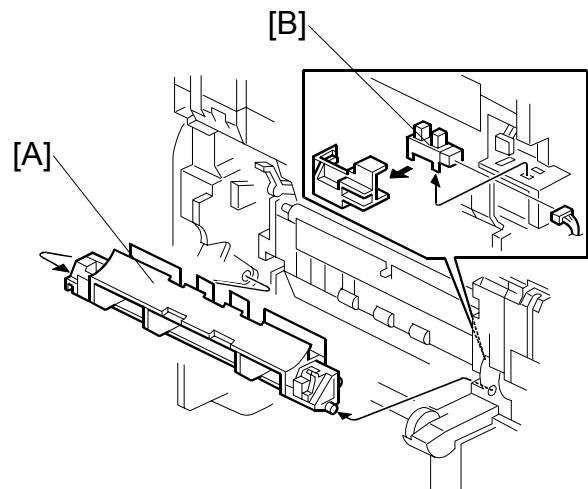

G105R139.WMF

3.4.6 PAPER VOLUME SENSOR, END SENSOR AND PAPER WIDTH SENSOR

1. Standard tray (☛ 3.4.1)
2. Front door
3. Fusing unit (☛ 3.8.1)
4. Harness cover [A] (🔩 x 1)
5. Front door cover [B] (🔩 x 1, 📐 x 2)

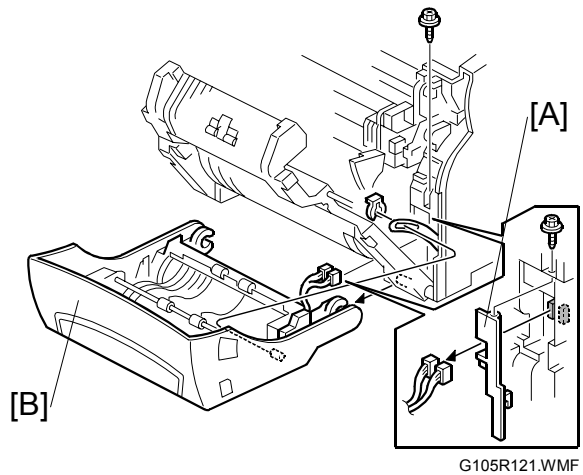

Replacement Adjustment

6. Registration guide (☛ 3.4.5)
7. Paper dust case holder [C]

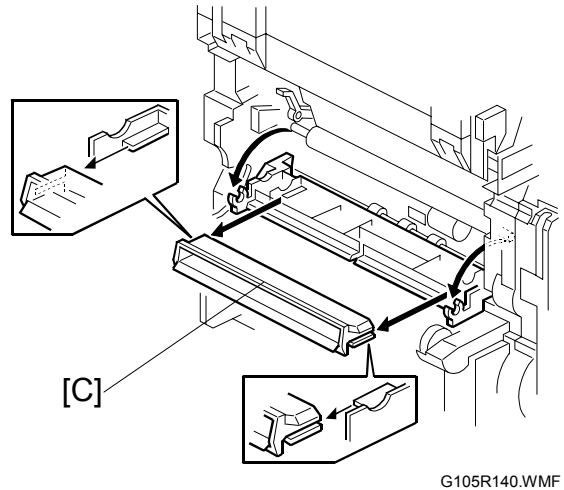

8. Tray paper sensor box [D] (🔩 x 2)

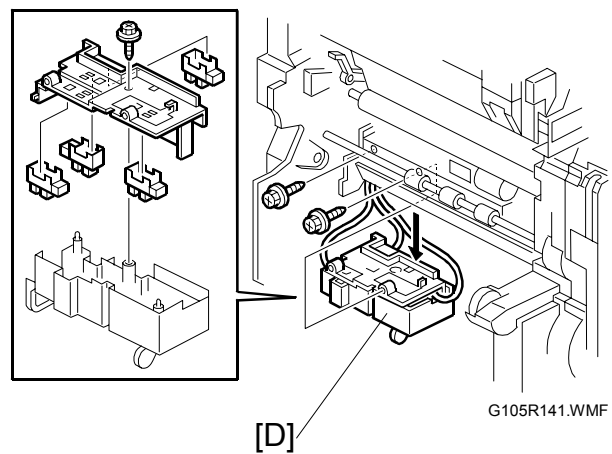

- 9. Tray paper sensor box cover [A] (🔩 x 1,)
- 10. Paper height sensor [B] (🔌 x 1)
- 11. Paper height sensor [C] (🔌 x 1)
- 12. Paper end sensor [D] (🔌 x 1)
- 13. Paper width sensor [E] (🔌 x 1)

NOTE: Each sensor and each cable have a number written on them. Make sure to connect the correct cables to each sensor.

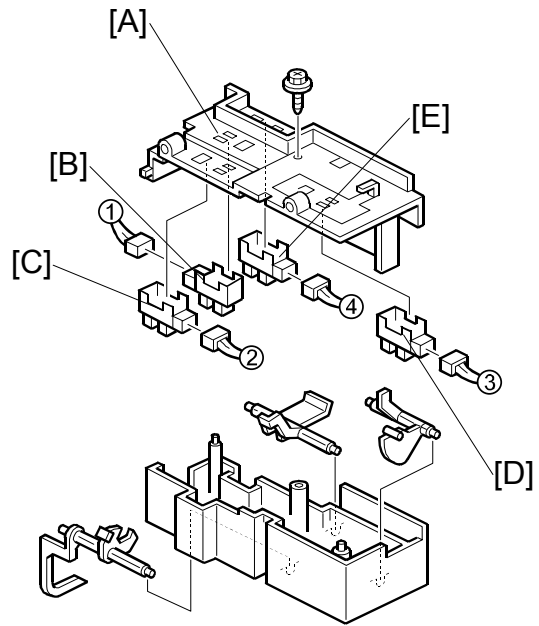

G105R142.WMF

3.4.7 PAPER SIZE SENSOR AND TEMPERATURE/ HUMIDITY SENSOR

- 1. Standard tray (☛ 3.4.1)
- 2. Rear cover [A]
- 3. Paper size sensor [B] (🔌 x 1)
- 4. Temperature/Humidity sensor [C] (🔩 x 1, 🔌 x 1)

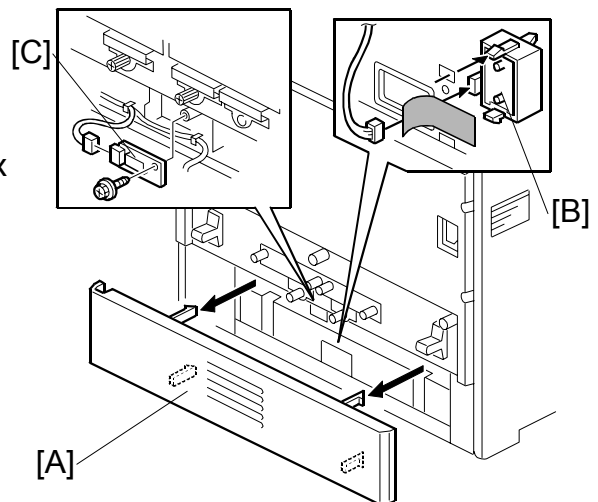

G105R147.WMFF

3.4.8 PAPER FEED MOTOR

1. Front door cover (☛ 3.4.6)
2. Right cover (🔩 x 1)
3. Side bar (☛ 3.2.1)
4. Harness guide [A] (🔩 x 1, 📏 x 3)
5. Front support unit [B] (🔩 x 3)

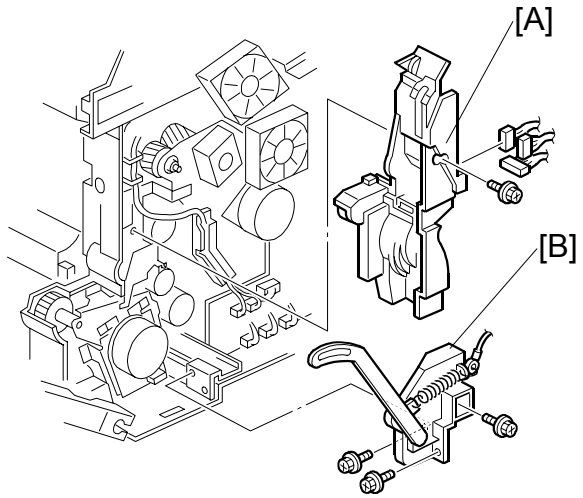

G105R128.WMF

Replacement
Adjustment

6. Paper feed motor [C] (🔩 x 4, 📏 x 1)

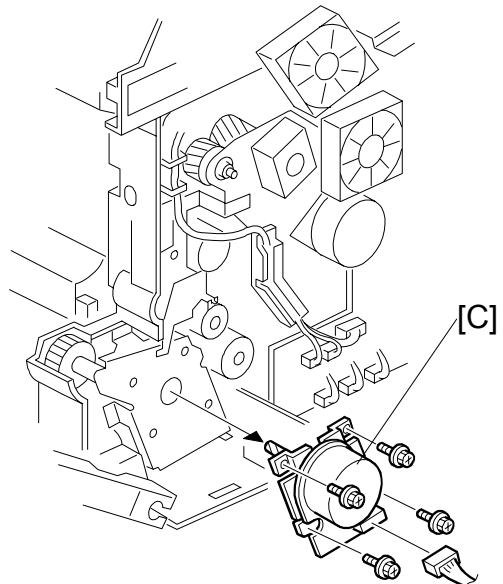

G105R131.WMF

3.4.9 PAPER REGISTRATION CLUTCH, PAPER FEED CLUTCH AND BY-PASS CLUTCH

1. Front door
2. Front door cover (☛ 3.2.1)
3. Right cover (☛ 3.2.1)
4. Side bar (☛ 3.2.1)
5. Harness cover (☛ 3.7.3)
6. Paper registration clutch [A] (☛ x 1, ☛ x1)
7. By-pass clutch [B] (☛ x 1, ☛ x 1)
8. Front support unit (☛ 3.5.5)
9. Paper feed clutch support [C] (☛ x 1)
10. Paper feed clutch [D] (☛ x 1)

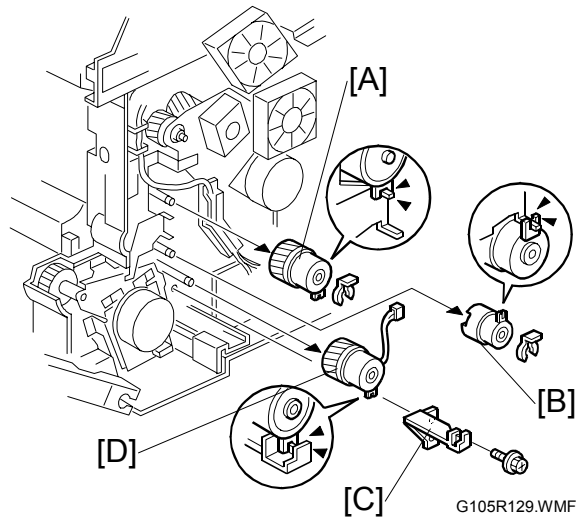

3.5 DEVELOPMENT

3.5.1 COLOR DEVELOPMENT MOTOR, COLOR OPC MOTOR AND BLACK OPC/DEVELOPMENT MOTOR

1. Front door
2. Right cover (☛ 3.2.1)
3. Color development motor [A] (🔩 x 4, 📐 x 1)
4. Color OPC motor [B] (🔩 x 4, 📐 x 1)
5. Black OPC/development motor [C] (🔩 x 4, 📐 x 1)

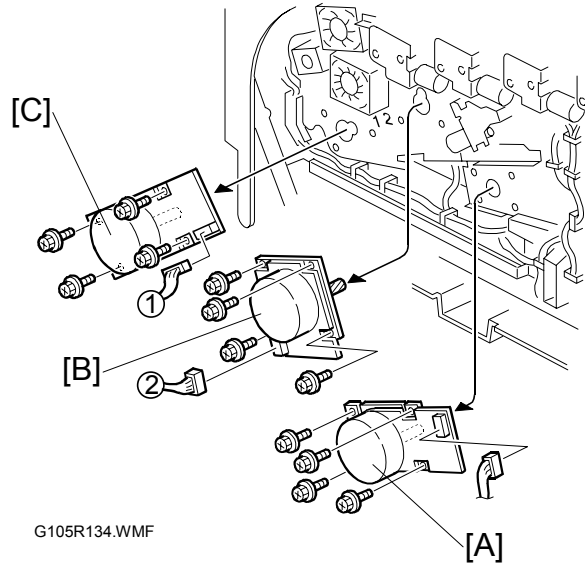

3.5.2 DEVELOPMENT CLUTCH

1. Front door
2. Top cover
3. Right cover (☛ 3.2.1)
4. Development clutch plate [A] (🔩 x 2)
5. Development clutch [B] (metal pin x 1, 📐 x 1)

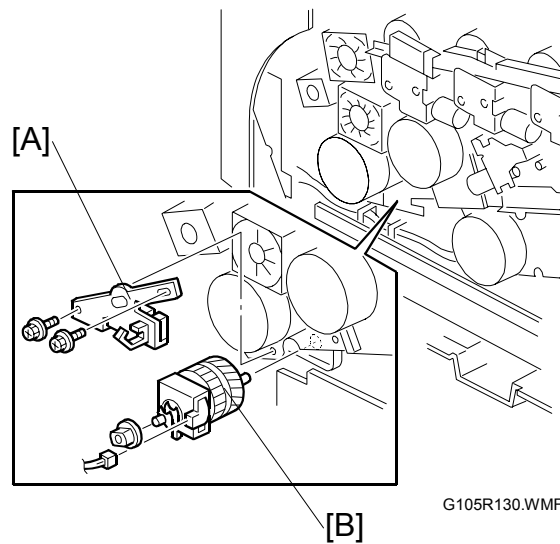

3.5.3 TRANSFER BELT CONTACT MOTOR

1. Front door
2. Top cover
3. Right cover (☛ 3.2.1)
4. Transfer belt contact motor unit [A]
(⚙ x 2, ⚙ x 1)

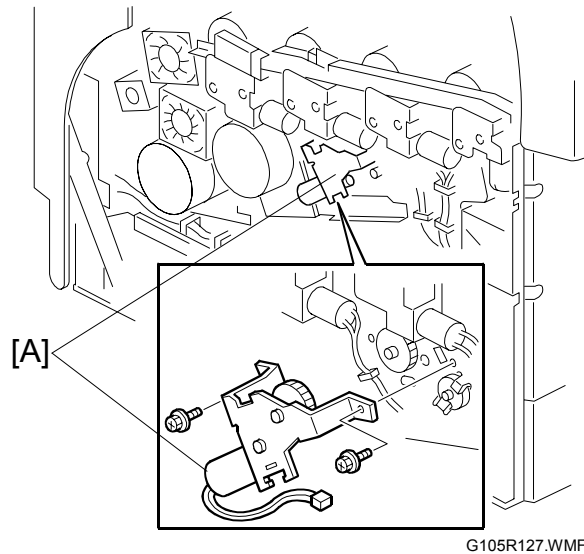

G105R127.WMF

3.5.4 TONER SUPPLY MOTOR

1. Front cover
2. Top cover
3. Right cover (☛ 3.2.1)
4. Toner supply motor unit [A] (⚙ x 2, ⚙ x 1)
5. Toner supply motor [B] (⚙ x 2)

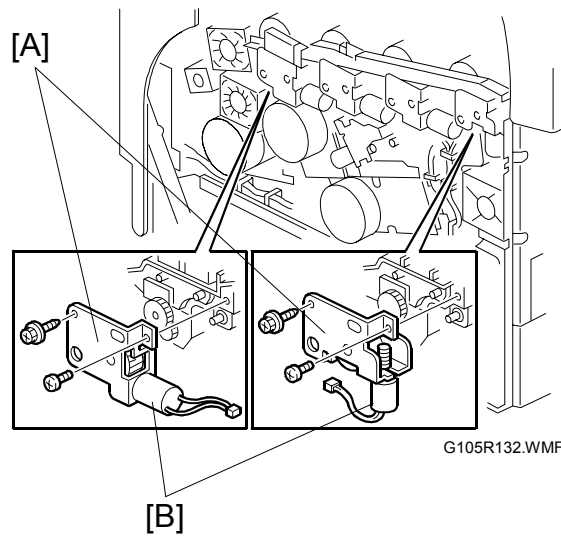

G105R132.WMF

3.5.5 TRANSFER ROLLER CONTACT MOTOR

1. Front door
2. Left cover
3. Front door support unit [A] (⚙️ x 2, ⚙️ x 1)

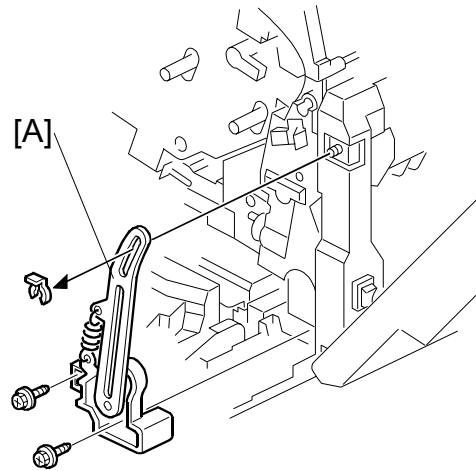

G105R143.WMF

Replacement Adjustment

4. Inner cover [B] (⚙️ x 2)

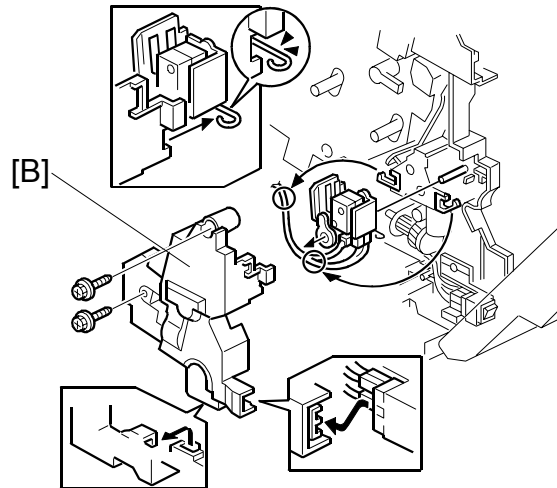

G105R144.WMF

5. Transfer roller contact motor unit [C] (⚙️ x 2, ⚙️ x 1)
6. Transfer roller contact motor [D] (⚙️ x 2)

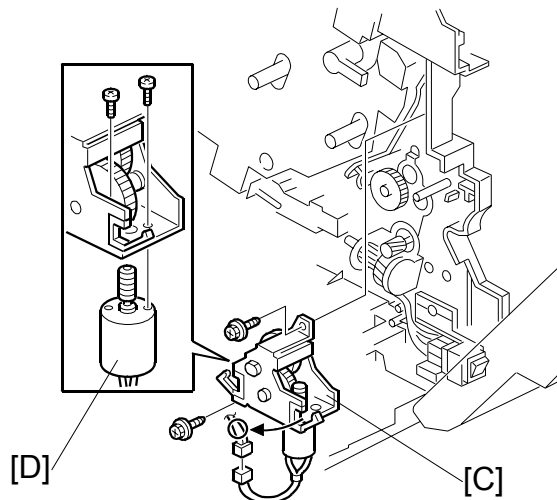

G105R145.WMF

3.5.6 ID SENSORS

1. Front door
 2. Fusing unit (☛ 3.8.1)
 3. ID sensor cover [A] (🔩 x 1)
 4. ID sensor bracket [B] (🔩 x 3, 📏 x 1)
- NOTE:** Do SP 2111 4 to adjust the ID sensors after you replace the ID sensor.

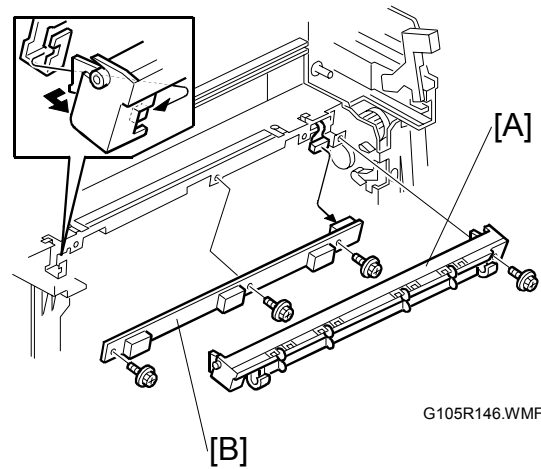

3.6 DRIVE

3.6.1 DRIVE UNIT

1. Top cover
 2. Front door
 3. Left cover
 4. Transfer belt unit
 5. PCU x 4
 6. Toner bottle x 4
 7. Toner supply motor unit x 4 (☛ 3.5.4)
- NOTE:** Clean the toner hopper and toner transport path before you remove the toner supply motor unit. If not, toner scattering can occur.

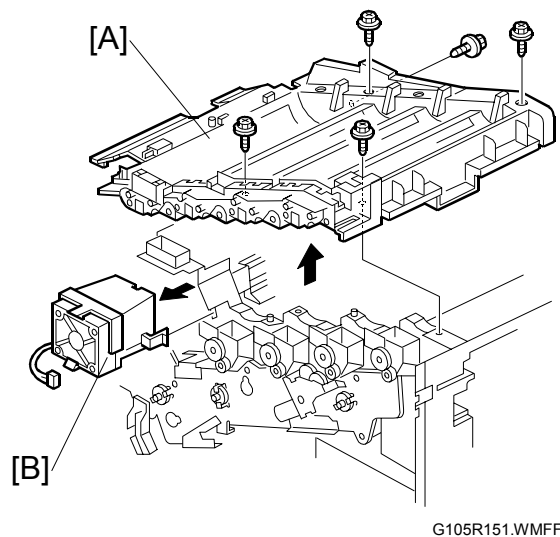

8. Right cover (☛ 3.2.1)
9. Top frame [A] (🔩 x 5)
10. Fusing unit fan [B] (📏 x 1)
11. Harness guide [C] (🔩 x 2)
12. Drive unit [D] (🔩 x 6, 📏 x 16)

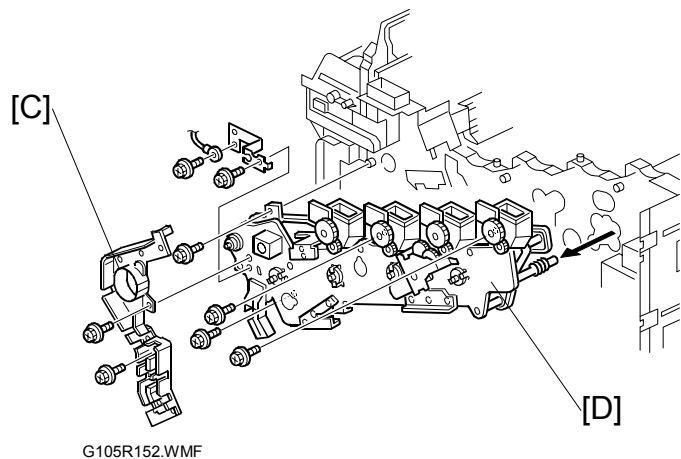

3.7 DUPLEX

3.7.1 DUPLEX JAM SENSOR

1. Front door cover (☛ 3.4.6)
2. Duplex jam sensor 1 [A] (☛ x 1)
3. Duplex jam sensor 2 [B] (☛ x 1)

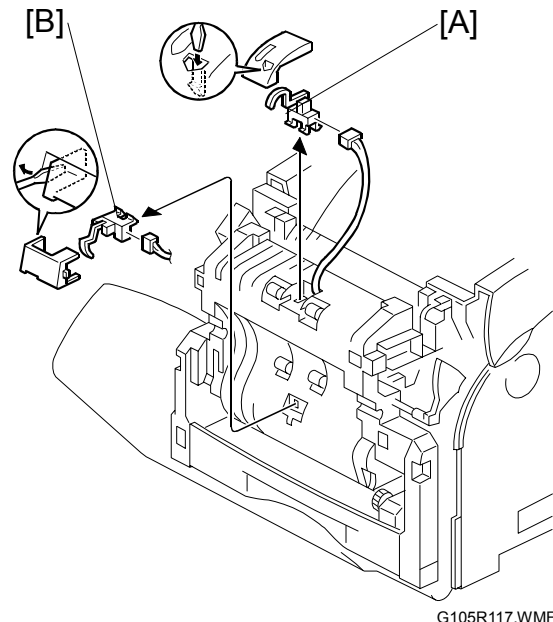

G105R117.WMF

3.7.2 INVERTER SENSOR

1. Front door
2. Duplex paper guide plate [A] (☛ x 6)
3. Inverter sensor board [B]
4. Inverter sensor [C] (☛ x 1)

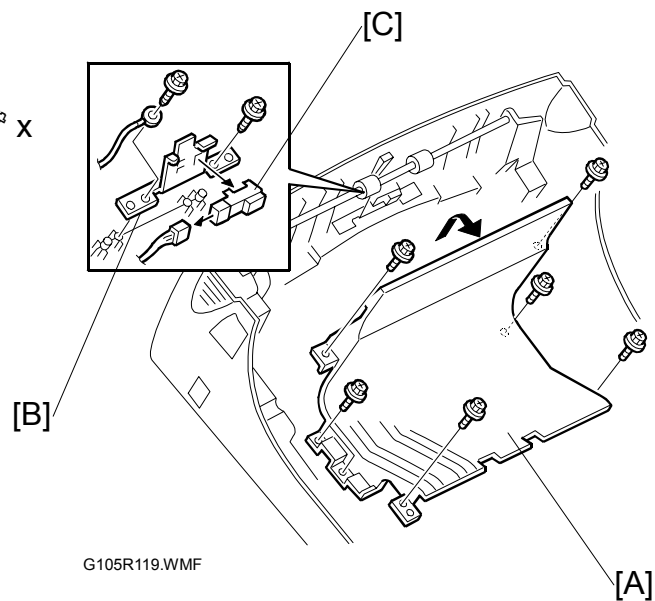

G105R119.WMF

3.7.3 DUPLEX MOTOR AND INVERTER MOTOR

1. Front door
2. Front door cover (☛3.4.6)
3. Duplex paper guide plate [A] (🔩 x 6)
4. Harness cover [B] (🔩 x 2)

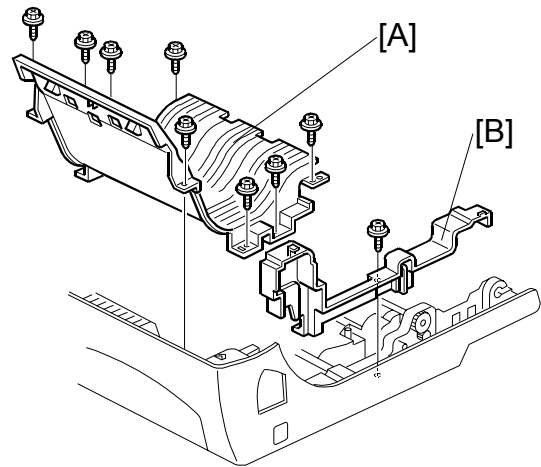

G105R153.WMF

5. Inverter motor [C] (🔩 x 2, ⚙️ x 1)
6. Harness [D]
7. Harness cover [E]
8. Duplex roller unit [F] (🔩 x 4)
9. Duplex motor [G] (🔩 x 2, ⚙️ x 1)

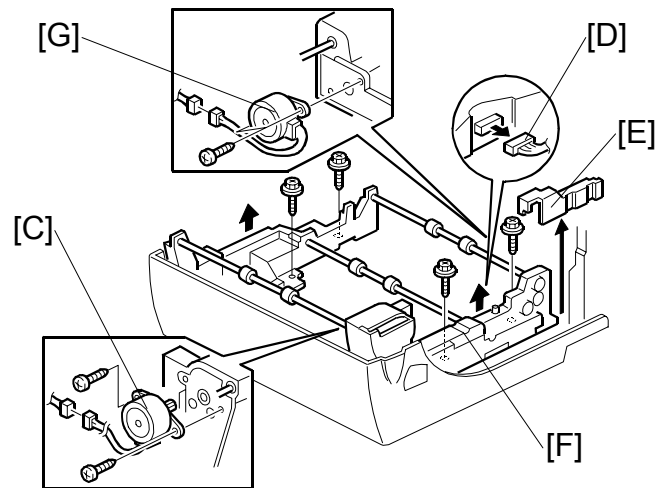

G105R154.WMF

3.8 FUSING

⚠ CAUTION

1. Make sure that the fusing unit is cool before you touch it. The fusing unit can be very hot.
2. Make sure to restore the insulators, shields, etc after you service the fusing unit.

3.8.1 FUSING UNIT

1. Front door
2. Fusing unit [A]

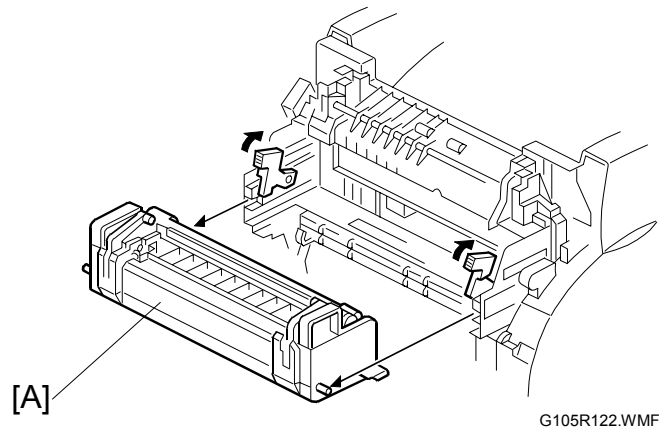

G105R122.WMF

3.8.2 THERMISTOR AND THERMOSTAT

1. Front door
2. Fusing unit (☛ 3.8.1)
3. Fusing unit upper cover [A] (⚙ x 4)
4. Fusing unit lower cover [B] (⚙ x 6)

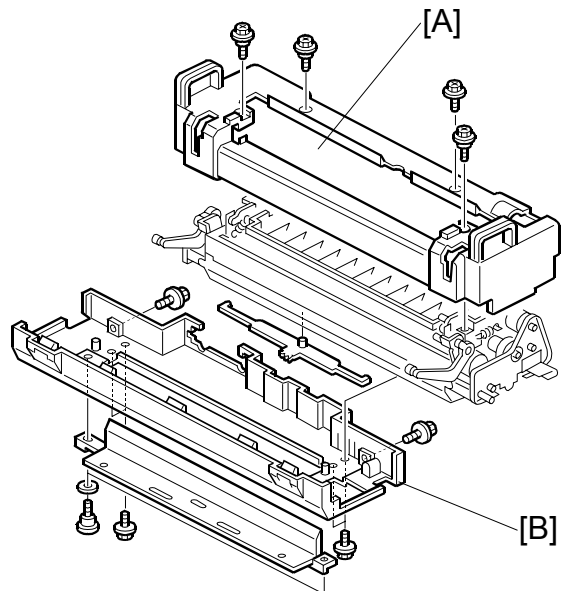

G105R126.WMF

5. Fusing supporter right [A] (⚙️ x 2) and left plate [B] (⚙️ x 2)

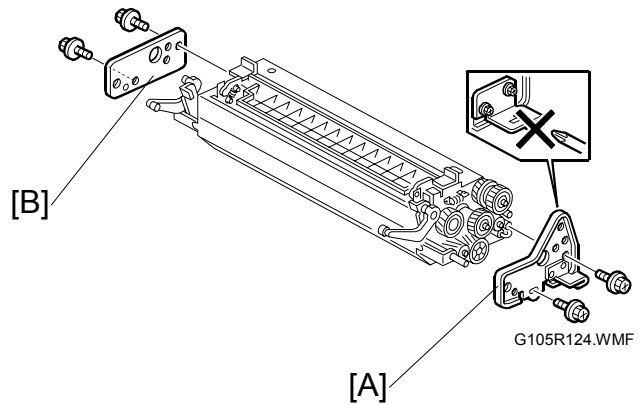

6. Thermistor [C] (⚙️ x 1, 📏 x 1)
 7. Thermostat [D] x 2 (⚙️ x 3)
- NOTE:** Do not recycle a thermostat that is already opened. Safety is not guaranteed if you do this.

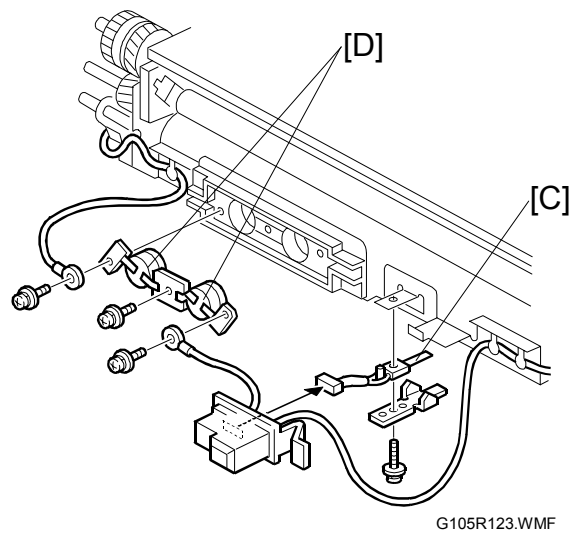

3.8.3 FUSING LAMP

1. Fusing unit
2. Fusing unit upper and lower cover (☛ 3.8.2)
3. Fusing supporter right and left plate (☛ 3.8.2)
4. Fusing lamp supporter right [A] (⚙️ x 1) and left plate [B] (⚙️ x 1)
5. Fusing lamp [C] (⚙️ x 2)

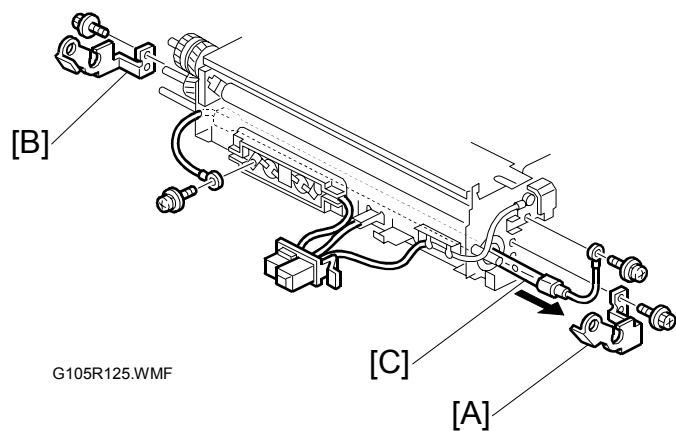

3.8.4 FUSING EXIT SENSOR AND PAPER EXIT SENSOR

1. Front door
2. Paper exit unit (⚙️ x 3)
3. Sensor board [A] (⚙️ x 1, 📡 x 2)
4. Fusing exit sensor [B]
5. Paper exit sensor [C]

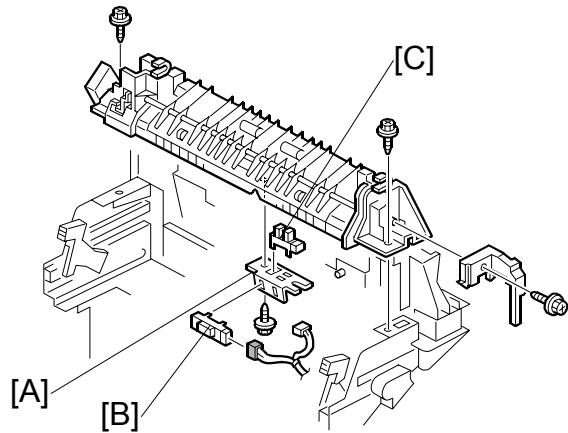

G105R116.WMF

Replacement
Adjustment

3.8.5 FUSING REGISTRATION SENSOR

1. Front door
2. Paper guide [A] (⚙️ x 2, 📡 x 1)
3. Fusing registration sensor [B]

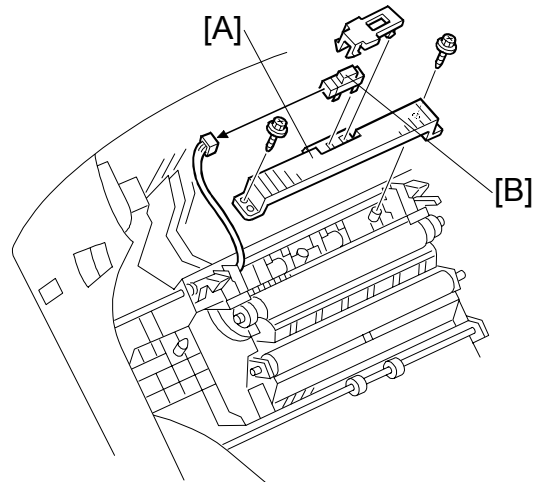

G105R118.WMF

3.8.6 FAN DIRECTION

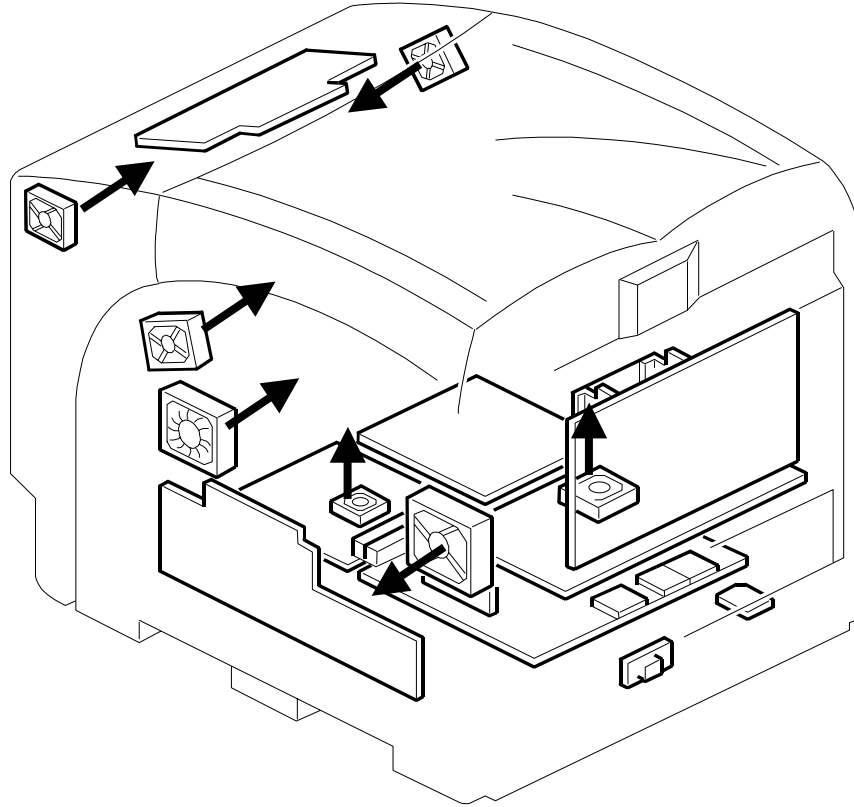

G105V204.WMF

NOTE: You must reinstall the cooling fans in the original orientations. Do not reinstall the cooling fans opposite to the original orientations, or the air will be blown in the wrong directions.

3.9 ADJUSTMENTS

3.9.1 GAMMA ADJUSTMENT

NOTE: Clean and/or replace related parts first to solve color quality problems. Do these procedures if adjustments are necessary:

Summary

To adjust the printer gamma:

- Select the print mode you want to calibrate
- Print a color calibration test sheet
- Make the gradation scales on the printout smooth from the lowest to the highest density. Adjust the CMY gradation scale at the top of the chart by balancing the density of the C, M, and Y gradation scales – the CMY gray scale should change smoothly from minimum to maximum. There should be no coloration.

Replacement Adjustment

Examine this color adjustment sheet:

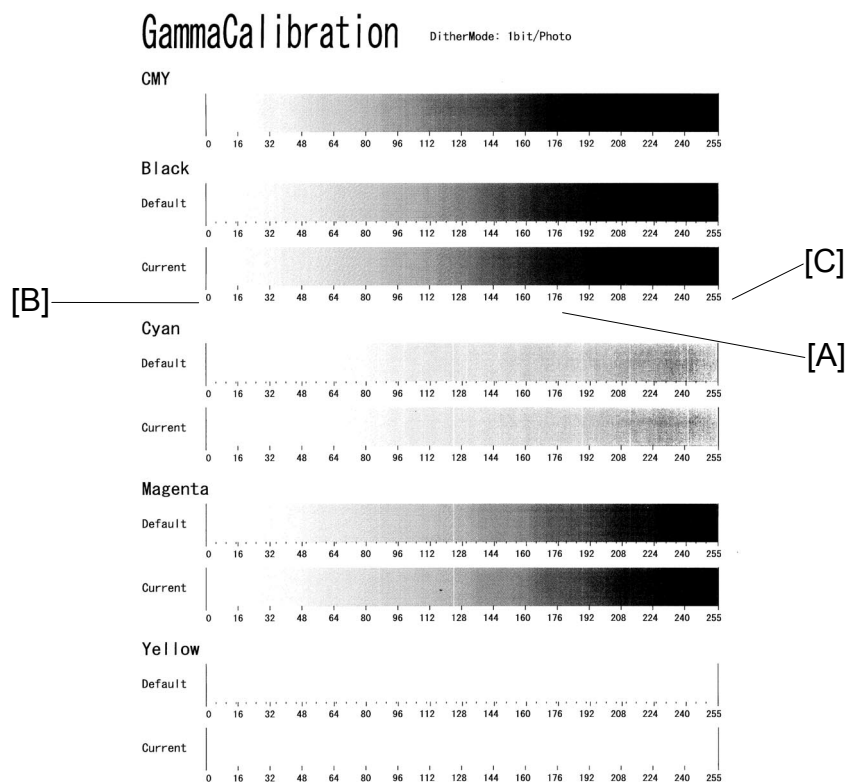

G105R913.JPG

You can adjust 15 points for each color: (example [A]) between 0 (lowest density) [B] and 255 (highest density) [C]. For each point, you can adjust the density within 0 and 255.

The gradation scales marked 'Default' are printed according to the default gamma settings in the flash ROM in the controller. The gamma adjustment changes the densities at the adjustable points in the gradation scale. The gradation scale marked "Current" shows the current settings.

Compare the "Current" gradation scale with the 'Default' at the time you do the adjustment procedure. Select the density for each of the 15 adjustable points, excluding points 0 and 255, from the 'Default' gradation scale.

The NVRAM holds three sets of controller gamma settings:

- Those saved this time: Controller SP 1101 ToneCtlSet - Tone (Current)
- Those saved in the previous adjustment: Controller SP 1101 ToneCtlSet - Tone (Prev)
- The factory settings: Controller SP 1101 ToneCtlSet - Tone (Factory).

Adjustment Procedure

1. Enter the controller service mode.
2. Use the down arrow key to select Controller SP 1102 "ToneCtlSet". Then press the Enter key.
3. Use the up/down key to select the mode you want to calibrate, Then press the Escape key until you get back to the controller service mode menu.
4. Use the down arrow key to select Controller SP 1103 "PrnColorSheet". Then press the Enter key.
5. Use the up/down key to select Controller SP 1103 001 "ToneCtlSheet" (normally this is displayed by default). Then press the Enter key.
6. Press the Enter key to print out the "color calibration test sheet". When "Execute?" shows.
7. Press the Escape key 2 times to exit from the menu. when "Execute OK" shows. (You return to Controller SP 1103 "PrnColorSheet" in the controller service menu.)
8. Use the down arrow key to select Controller SP 1104 "ToneCtlValue". Then press the enter key.

9. Use the up/down arrow key to select the setting you want to adjust. Then press the enter key. The three digits in the display (example '016') indicate a position on the color calibration test sheet.

Operation Panel Display	Color Calibration Test Sheet
Set Black 1	Default Value 16
Set Black 2	Default Value 32
Set Black 3	Default Value 48
⋮	⋮
Set Black 13	Default Value 208
Set Black 14	Default Value 224
Set Black 15	Default Value 240
Set Cyan 1 ~ 15	See Set Black 1 ~ 15
Set Magenta 1 ~ 15	See Set Black 1 ~ 15
Set Yellow 1 ~ 15	See Set Black 1 ~ 15

Adjust the color density at each of the 15 points for each of the four colors.

NOTE: 1) Do these to decide what density value to input:

- 2) Look at the color adjustment sheet.
- 3) Look at the gradation scale entitled 'Default' for the color you want to adjust.
- 4) Go along the scale until you reach the density you want to input.
- 5) Read off the value on the scale and store it in the machine.
 - a) Use the up/down key to move the cursor along the three-digit display. Then press the Enter key.
 - b) Use the up/down key to change the digit at the cursor. Then press the Enter key.
 - c) Press the Escape key to exit from the menu.
- 6) Do the same for all 15 points.

10. When the density setting is complete for all colors, print out a color adjustment sheet again and make sure that the gradation scale for each printed color is smooth and that the CMY gradation scale is gray. Do the adjustment again if there is an anomaly (normally, repeat this procedure 3 to 5 times).

11. Do these when the adjustment results are satisfactory:

- 1) Use Controller SP 1105 "ToneCtlSave" in the controller service menu, to store the new settings in the controller.
- 2) Reset the controller (press the **[Reset]** key when the machine is off line") to use the new settings.

NOTE: You must reset the controller to keep the new settings in the controller NVRAM.

4. TROUBLESHOOTING

4.1 PROCESS CONTROL RESULT

The table below lists the process control results shown in SP 3821.

Number	Result	Notes
10	Success	No error
21	ID sensor correction error	SC 400
22	ID sensor: LED adjustment error	SC 418
31	Charge bias correction error	SC 300 to 307
51	High Vmin (Bk), High K2 (Color) error	SP3145 NOTE
52	Low K2 (Color) error	SP3146 NOTE
53	High K5 error	SP3147 NOTE
54	Low K5 error	SP3147 NOTE
55	High development gamma	$\gamma > 5.0$, NOTE
56	Low development gamma	$\gamma < 0.5$, NOTE
57	Development bias adjustment error	Vk > 150V NOTE
58	Development bias adjustment error	Vk < -150V NOTE
90	No process control	-
99	Not successful	Interrupt during the process control (e.g. Door open)

NOTE: This error code does not usually occur. If no problem is observed with image density and/or development gamma, nothing needs to be done. If an image problem such as low image density is observed, check the following points: Transfer belt / PCU / ID sensor / Toner Bottle

The 8 numbers on the LCD in SP 3821 indicate the process control result for each color.

There are two numbers for each color. The numbers are shown from left to right on the display as follows: Black, Magenta, Cyan, Yellow.

For example, if process control for each color is successful:

10 (Black), 10 (Magenta), 10 (Cyan), 10 (Yellow)

4.2 SERVICE CALL CONDITIONS

4.2.1 SUMMARY

1. All SCs are logged.
2. First disconnect then reconnect the connectors before you replace the PCBs if the problem concerns electrical circuit boards.
3. First check the mechanical load before you replace motors or sensors if the problem concerns a motor lock.

There are 4 levels of service call conditions.

Level	Definition	Reset Procedure
A	To prevent damage to the machine, the main machine cannot be operated until a service representative has reset the SC.	Do SP 5810, and then turn the main power switch off and on.
B	SCs that disable only the features that use the defective item. Although these SCs are not shown to the user under normal conditions, they are displayed on the operation panel only when the defective feature is selected.	Turn the operation switch or main switch off and on.
C	The SC history is updated. The machine can be operated as usual.	The SC will not be displayed. Only the SC history is updated.
D	Turning the main switch off then on resets SCs displayed on the operation panel. These are redisplayed if the error occurs again.	Turn the operation switch off and on.

4.2.2 SC CODE DESCRIPTIONS

NOTE: Remove the NVRAM from the old board and install it on the new one when you replace the EGB or the controller board.

- The SC level is indicated under SC number in the below list.
- The symbol “•” that is in the “Possible Cause/ Requirement Action” column indicates the possible cause.
- The figure “1,etc.” that is in the “Possible Cause/Requirement Action” column indicates the requirement action.

Engine SC

SC [Level]	Item	
	Symptom	Possible Cause/Required Action
195 [D]	Incorrect serial number	
	When checking the registered product number, it does not match the printer's product number.	<ul style="list-style-type: none"> • Registered product number does not match the printer's product number. <ol style="list-style-type: none"> 1. Try again to input the correct product number with SP5811-001.
202 [D]	Polygon motor error: Time out with the polygon motor activated	
	After the polygon motor turns on or changes the speed, the SCRDI_N is not active within 10 seconds.	<ul style="list-style-type: none"> • Disconnected cable from the polygon motor drive board or defective connection • Defective polygon motor or drive board
203 [D]	Polygon motor error: Time out with the polygon motor inactivated	
	After the polygon motor turns off or changes the speed, the SCRDI_N is not inactive within 10 seconds.	<ul style="list-style-type: none"> • Disconnected cable from the polygon motor drive board or defective connection • Defective polygon motor or drive board
204 [D]	Polygon motor error: XSCRDI signal error	
	PMRDI_N signal consecutively detects that the polygon motor is an inactive state while LDB unit scans.	<ul style="list-style-type: none"> • Disconnected cable from the polygon motor drive board or defective connection • Defective polygon motor or drive board <ol style="list-style-type: none"> 1. Check the connectors. 2. Replace the polygon motor. 3. Replace the polygon motor drive board.
205 [D]	Polygon motor error: XSCRDI signal not stable	
	PMRDI_N signal consecutively detects that the polygon motor is an inactive state while the polygon motor turns on or changes the speed.	<ul style="list-style-type: none"> • Disconnected cable from the polygon motor drive board or defective connection • Defective polygon motor or drive board. <ol style="list-style-type: none"> 1. Check the connectors. 2. Replace the polygon motor. 3. Replace the polygon motor drive board.



Trouble-shooting

SC [Level]	Item	
	Symptom	Possible Cause/Required Action
210 [C]	Trailing edge laser detection error: [K]	
	The laser synchronizing detection signal for LDB [K] of the trailing edge is not detected for one second after the LDB unit turned on when detecting the main scan magnification.	<ul style="list-style-type: none"> • Disconnected cable from the laser synchronizing detection unit or defective connection • Defective laser synchronizing detector • Defective LDB • Defective EGB <ol style="list-style-type: none"> 1. Check the connectors. 2. Replace the laser-synchronizing detector. 3. Replace the LDB. 4. Replace the EGB.
211 [C]	Trailing edge laser detection error: [Y]	
	The laser synchronizing detection signal for LDB [Y] of the trailing edge is not detected for one second after the LDB unit turned on when detecting the main scan magnification.	Same as SC 210
212 [C]	Trailing edge laser detection error: [M]	
	The laser synchronizing detection signal for LDB [M] of the trailing edge is not detected for one second after the LDB unit turned on when detecting the main scan magnification.	Same as SC 210
213 [C]	Trailing edge laser detection error: [C]	
	The laser synchronizing detection signal for LDB [C] of the trailing edge is not detected for one second after the LDB unit turned on when detecting the main scan magnification.	Same as SC 210
220 [D]	Laser Synchronizing Detection Error: LDB of the leading edge [K]	
	The laser synchronizing detection signal for LDB [K] of the leading edge is not output for two seconds after LDB unit turns on while the polygon motor is rotating normally.	<ul style="list-style-type: none"> • Disconnected cable from the laser synchronizing detection unit or defective connection • Defective laser synchronizing detector • Defective LDB • Defective EGB <ol style="list-style-type: none"> 1. Check the connectors. 2. Replace the laser-synchronizing detector. 3. Replace the LDB. 4. Replace the EGB.

SC [Level]	Item	
	Symptom	Possible Cause/Required Action
222 [D]	Leading edge laser detection error: [Y] The laser synchronizing detection signal for LDB [Y] of the leading edge is not output for two seconds after LDB unit turns on while the polygon motor is rotating normally.	Same as SC 221
224 [D]	Leading edge laser detection error: [M] The laser synchronizing detection signal for LDB [M] of the leading edge is not output for two seconds after LDB unit turns on while the polygon motor is rotating normally.	Same as SC 221
226 [D]	Leading edge laser detection error: [C] The laser synchronizing detection signal for LDB [C] of the leading edge is not output for two seconds after LDB unit turns on while the polygon motor is rotating normally.	Same as SC 221
230 [C]	FGATE: On error [K] The PFGATE ON signal does not assert within 5 seconds after processing the image in normal job or MUSIC for [K] starts.	<ul style="list-style-type: none"> • Defective connection between the controller board and EGB • Defective cable between the EGB and LDB <ol style="list-style-type: none"> 1. Check the connectors. 2. Replace the LDB. 3. Replace the EGB.
231 [C]	FGATE: Off error [K] 1. The PFGATE ON signal still asserts within 5 seconds after processing the image in normal job or MUSIC for [K] ends. 2. The PFGATE ON signal still asserts when the next job starts.	<ul style="list-style-type: none"> • Defective connection between the controller board and EGB • Defective cable between the EGB and LDB <ol style="list-style-type: none"> 1. Check the connectors. 2. Replace the LDB. 3. Replace the EGB.
232 [C]	FGATE: On error [Y] The PFGATE register of GAVD does not assert within 5 seconds after processing the image in normal job or MUSIC for [Y] started.	Same as SC 230

Trouble-shooting

SC [Level]	Item	
	Symptom	Possible Cause/Required Action
233 [C]	FGATE: Off error [Y] 1. The PFGATE ON signal still asserts within 5 seconds after processing the image in normal job or MUSIC for [K] ends. 2. The PFGATE ON signal still asserts when the next job starts.	Same as SC 231
234 [C]	FGATE: On error [M] The PFGATE register of GAVD does not assert within 5 seconds after processing the image in normal job or MUSIC for [M] started.	Same as SC 230
235 [C]	FGATE: Off error [M] 1. The PFGATE ON signal still asserts within 5 seconds after processing the image in normal job or MUSIC for [M] ends. 2. The PFGATE ON signal still asserts when the next job starts.	Same as SC 231
236 [C]	FGATE: On error [C] The PFGATE register of GAVD does not assert within 5 seconds after processing the image in normal job or MUSIC for [C] started.	Same as SC 230
237 [C]	FGATE: Off error [C] 1. The PFGATE ON signal still asserts within 5 seconds after processing the image in normal job or MUSIC for [C] ends. 2. The PFGATE ON signal still asserts when the next job starts.	Same as SC 231
240 [D]	LDB error [K] The EGB detects LDB error a few times consecutively when LDB unit turns on after LDB initialisation.	<ul style="list-style-type: none"> • Defective LDB 1. Replace the LDB.

SC [Level]	Item	
	Symptom	Possible Cause/Required Action
241 [D]	LDB error [Y] The EGB detects LDB error a few times consecutively when LDB unit turns on after LDB initialisation.	Same as SC240
242 [D]	LDB error [M] The EGB detects LDB error a few times consecutively when LDB unit turns on after LDB initialisation.	Same as SC240
243 [D]	LDB error [C] The EGB detects LDB error a few times consecutively when LDB unit turns on after LDB initialisation.	Same as SC240
270 [D]	LDU shutter error Sensor output does not change even if 1 second passes after the LDU shutter motor is on.	<ul style="list-style-type: none"> • Sensor defective or LDU shutter motor defective <ol style="list-style-type: none"> 1. Replace the LDU shutter sensor or shutter motor.
 300 [D]	High voltage power board: Charge voltage output error [K] The measured voltage is not proper when EGB measures the charge output for each color.	<ul style="list-style-type: none"> • Defective charge roller • Defective connectors • Disconnected harness • Defective high voltage power 1 <ol style="list-style-type: none"> 1. Check the connectors. 2. Replace the PCU for black. 3. Replace the drum positioning plate. 4. Replace the high voltage power 1.
 301 [D]	High voltage power board: Charge voltage output error [M] The measured voltage is not proper when EGB measures the charge output for each color.	<ul style="list-style-type: none"> • Defective charge roller • Defective connectors • Disconnected harness • Defective high voltage power 1 <ol style="list-style-type: none"> 1. Check the connectors. 2. Replace the PCU for magenta. 3. Replace the drum positioning plate. 4. Replace the high voltage power 1.
 302 [D]	High voltage power board: Charge voltage output error [C] The measured voltage is not proper when EGB measures the charge output for each color.	<ul style="list-style-type: none"> • Defective charge roller • Defective connectors • Disconnected harness • Defective high voltage power 1 <ol style="list-style-type: none"> 1. Check the connectors. 2. Replace the PCU for cyan. 3. Replace the drum positioning plate. 4. Replace the high voltage power 1.

Trouble-shooting



SC [Level]	Item	
	Symptom	Possible Cause/Required Action
303 [D]	High voltage power board: Charge voltage output error [Y]	
	The measured voltage is not proper when EGB measures the charge output for each color.	<ul style="list-style-type: none"> • Defective charge roller • Defective connectors • Disconnected harness • Defective high voltage power 1 <ol style="list-style-type: none"> 1. Check the connectors. 2. Replace the PCU for yellow. 3. Replace the drum positioning plate. 4. Replace the high voltage power 1.
304 [D]	Charge AC bias error [K]	
	The charge current less than 200 μ A is detected.	<ul style="list-style-type: none"> • Defective charge roller • Defective connectors • Disconnected harness • Defective high voltage power 1 <ol style="list-style-type: none"> 1. Check the connectors. 2. Replace the PCU for black. 3. Replace the drum positioning plate. 4. Replace the high voltage power 1.
305 [D]	Charge AC bias error [M]	
	The charge current less than 200 μ A is detected.	<ul style="list-style-type: none"> • Defective charge roller • Defective connectors • Disconnected harness • Defective high voltage power 1 <ol style="list-style-type: none"> 1. Check the connectors. 2. Replace the PCU for magenta. 3. Replace the drum positioning plate. 4. Replace the high voltage power 1.
306 [D]	Charge AC bias error [C]	
	The charge current less than 200 μ A is detected.	<ul style="list-style-type: none"> • Defective charge roller • Defective connectors • Disconnected harness • Defective high voltage power 1 <ol style="list-style-type: none"> 1. Check the connectors. 2. Replace the PCU for cyan. 3. Replace the drum positioning plate. 4. Replace the high voltage power 1.
307 [D]	Charge AC bias error [Y]	
	The charge current less than 200 μ A is detected.	<ul style="list-style-type: none"> • Defective charge roller • Defective connectors • Disconnected harness • Defective high voltage power 1 <ol style="list-style-type: none"> 1. Check the connectors. 2. Replace the PCU for yellow. 3. Replace the drum positioning plate. 4. Replace the high voltage power 1.

SC [Level]	Item	
	Symptom	Possible Cause/Required Action
325 [D]	Color development motor error	
	<ol style="list-style-type: none"> 1. LOCK signal is not detected for more than two seconds while the motor START signal is on. 2. LOCK signal is not cancelled within two seconds after the motor is off. 	<ul style="list-style-type: none"> • Color development motor slip due to the increase of the load torque <ol style="list-style-type: none"> 1. Adjust the load torque properly by replacing or cleaning the development unit. 2. Replace or repair the development motor if the load torque is normal.
360 [D]	TD sensor: Output maximum error [K]	
	Vt is more than the maximum value (4.5) for three times consecutively.	<ul style="list-style-type: none"> • Defective connector connection • Increasing toner density <ol style="list-style-type: none"> 1. Replace the PCU.
361 [D]	TD sensor: Output maximum error [M]	
	Same as SC 360	
362 [D]	TD sensor: Output maximum error [C]	
	Same as SC 360	
363 [D]	TD sensor: Output maximum error [Y]	
	Same as SC 360	
364 [D]	TD sensor: Output minimum error [K]	
	Vt is less than the minimum value (0.5) for three times consecutively.	<ul style="list-style-type: none"> • Defective connector connection • Decreasing toner density <ol style="list-style-type: none"> 1. Replace the PCU.
365 [D]	TD sensor Output minimum error [M]	
	Same as SC 364	
366 [D]	TD sensor: Output minimum error [C]	
	Same as SC 364	
367 [D]	TD sensor: Output minimum error [Y]	
	Same as SC 364	
368 [D]	TD sensor: Initial control voltage error [K]	
	<ol style="list-style-type: none"> 1. Vt is less than 1 V even though the control power voltage is adjusted to the maximum. 2. Vt is more than 1 V even though the control power voltage is adjusted to the minimum. 	<ul style="list-style-type: none"> • Defective connector connection • Defective TD sensor • The toner density in the developer is different from the initial condition. <ol style="list-style-type: none"> 1. Replace the PCU.
369 [D]	TD sensor: Initial control voltage error [M]	
	Same as SC 368	
370 [D]	TD sensor: Initial control voltage error [C]	
	Same as SC 368	
371 [D]	TD sensor: Initial control voltage error [Y]	
	Same as SC 368	

Trouble-shooting

SC [Level]	Item	
	Symptom	Possible Cause/Required Action
372 [D]	TD sensor: Initial adjustment error [K] Vt is not ($A \pm 0.2$) when initial setting for TD sensor is executed. A = SP3011-001 for [K]	<ul style="list-style-type: none"> Defective connector connection Defective TD sensor The toner density in the developer is different from the initial condition. <ol style="list-style-type: none"> 1. Replace the PCU.
373 [D]	TD sensor: Initial adjustment error [M] Vt is not ($A \pm 0.2$) when initial setting for TD sensor is executed. A = SP3011-002 for [M]	Same as 372
374 [D]	TD sensor: Initial adjustment error [C]: same as 372 Vt is not ($A \pm 0.2$) when initial setting for TD sensor is executed. A = SP3011-003 for [C]	Same as 372
375 [D]	TD sensor: Initial adjustment error [Y]: same as 372 Vt is not ($A \pm 0.2$) when initial setting for TD sensor is executed. A = SP3011-004 for [Y]	Same as 372
380 [C]	Drum gear position sensor error When receiving the input signal of drum gear position sensor is not correctly done, SC380 is logged.	<ul style="list-style-type: none"> Unclean or defective drum gear position sensor <ol style="list-style-type: none"> 1 Clean the drum gear position sensor. 2 Replace the drive unit.
396 [D]	Drum motor error [K] The LOCK signal is not detected for 2 seconds more while the start signal of the drum motor for black PCU is output.	<ul style="list-style-type: none"> OPC motor slip due to the excessive load <ol style="list-style-type: none"> 1. Clean the PCU. 2. Check the cable from the Black OPC/ Development motor. Replace it if necessary. 3. Replace the EGB. 4. Replace the Black OPC/ Development motor.
397 [D]	Drum motor error [CMY] The LOCK signal is not detected for 2 seconds more while the start signal of the drum motor for color PCU is output.	Same as SC 396
400 [D]	ID sensor correction error Regular Vsp is not (4 ± 0.5 V) when ID sensor correction is executed.	<ul style="list-style-type: none"> Defective ID sensors Dirty ID sensors or transfer belt ID sensor life is over. <ol style="list-style-type: none"> 1. Replace the ID sensors.
418 [D]	ID sensor: LED adjustment error LED PWM adjustment is not [A] for three times consecutively. [A] = $50 < [A] < 400$	<ul style="list-style-type: none"> Defective ID sensors Dirty ID sensors or transfer belt ID sensor life is over. <ol style="list-style-type: none"> 1. Replace the ID sensors.

SC [Level]	Item	
	Symptom	Possible Cause/Required Action
442 [D]	Transfer belt contact error The transfer belt contact sensor does not detect the movement of actuator at the sensor while the polygon motor rotates.	<ul style="list-style-type: none"> • Dirty transfer belt contact sensor • Defective transfer belt contact motor • Disconnected connector of transfer belt contact sensor or motor • Disconnected cable <ol style="list-style-type: none"> 1. Replace the transfer belt contact sensor. 2. Replace the transfer belt contact motor.
452 [D]	Transfer roller contact error The transfer roller contact sensor does not detect the movement of actuator at the sensor while the polygon motor rotates.	<ul style="list-style-type: none"> • Defective transfer roller contact sensor • Defective transfer roller contact motor • Defective IOB <ol style="list-style-type: none"> 1. Replace the transfer roller contact sensor. 2. Replace the transfer roller contact motor. 3. Replace the IOB.
490 [D]	High Voltage Power 1: High voltage output error Error signal is detected for 10 times consecutively.	<ul style="list-style-type: none"> • One of the DC bias outputs for each PCU is shorted or one of the transfer belt bias outputs for [Y], [M] and [C]. • Power leaking • Defective connection • Disconnected cable • Defective PCU • Defective High Voltage Power 1 <ol style="list-style-type: none"> 1. Replace the High Voltage Power 1. 2. Reset the cables and components. 3. Replace the PCU.
491 [D]	High Voltage Power 2: High voltage output error Error signal is detected for 10 times consecutively.	<ul style="list-style-type: none"> • One of the separation bias output, development bias output and transfer belt cleaning bias output is shorted or one of the transfer belt bias output for [K] and transfer roller bias output is shorted. • Power leaking • Defective connection • Defective PCU • Defective High Voltage Power 2 <ol style="list-style-type: none"> 1. Replace the High Voltage Power 2. 2. Reset the cables and components. 3. Replace the PCU.
531 [D]	Paper feed / Fusing motor error 1. LOCK signal is not detected for more than two seconds while the motor START signal is on. 2. LOCK signal is not cancelled within two seconds after the motor is off.	<ul style="list-style-type: none"> • Defective paper feed/ fusing motor <ol style="list-style-type: none"> 1. Replace the paper feed/ fusing motor.

Trouble-shooting

SC [Level]	Item	
	Symptom	Possible Cause/Required Action
532 [D]	<p>Fan motor error</p> <p>The fan motor "On" signal is not detected for the components below after the drum motor for black is set to "On".</p> <ul style="list-style-type: none"> • PSU fan • Fusing unit fan • Polygon motor fan • Drive unit fan • Exit paper fan 	<ul style="list-style-type: none"> • Defective fan motor <ol style="list-style-type: none"> 1. If the error occurs again, one of the fans is defective. Remove the covers, find the defective fan and replace it.
541 [A]	<p>Thermistor error</p> <p>The thermistor output is less than 0°C for six seconds.</p>	<ul style="list-style-type: none"> • Disconnected thermistor • Defective connector connection
542 [A]	<p>Print ready temperature error</p> <ol style="list-style-type: none"> 1. The heating roller temperature increase that is less than 67 degrees for 9 seconds is detected five times consecutively. 2. The fusing temperature does not reach the print ready temperature within 15 seconds after the fusing lamp was controlled. 	<ul style="list-style-type: none"> • Defective thermistor • Thermistor coming off • Incorrect power supply input at the main power socket • Defective fusing lamp
543 [A]	<p>High temperature detection: Software</p> <p>The thermistor detects 230°C for 0.2 seconds.</p>	<ul style="list-style-type: none"> • Defective thermistor • Defective I/O board • Defective EGB
544 [A]	<p>High temperature detection: Hard</p> <p>The thermistor detects 250°C.</p>	<ul style="list-style-type: none"> • Defective thermistor • Defective I/O board • Defective EGB • Defective fusing unit, PSU, or EGB <ol style="list-style-type: none"> 1. Replace the fusing unit. 2. Replace the PSU.
545 [A]	<p>Heating lamp error</p> <p>The fusing lamp is full-powered for 8 seconds after the heating roller reaches the print ready temperature.</p>	<ul style="list-style-type: none"> • Deformed thermistor • Thermistor coming off • Defective fusing lamp

SC [Level]	Item	
	Symptom	Possible Cause/Required Action
547 [D]	<p>Zero cross error</p> <ol style="list-style-type: none"> The zero cross signal is detected three times even though the heater relay is off when turning on the main power. The zero cross signal is not detected for three seconds even though the heater relay is on after turning on the main power or closing the front door. The detection error occurs twice or more in the ten zero cross signal detections. This error is defined when the detected zero cross signal is less than 17 for 200 ms. 	<ul style="list-style-type: none"> Defective fusing lamp relay Defective fusing lamp relay circuit Unstable power supply <ol style="list-style-type: none"> Check the power supply source. Replace the PSU.
557 [C]	<p>Zero cross frequency error</p> <p>The detection error occurs ten times in a row in ten zero cross signal detections. This error is defined when the detected zero cross signal is more than 28 for 200 ms. This SC is only logged. In this case, the power frequency is defined as 60 Hz.</p>	<ul style="list-style-type: none"> Noise (High frequency) <ol style="list-style-type: none"> Check the power supply source.
670 [D]	<p>Engine start-up error</p> <p>The ready signal from the engine board is not detected.</p>	<ul style="list-style-type: none"> Defective engine board. <ol style="list-style-type: none"> Replace the engine board.
687 [D]	<p>Controller board command error</p> <p>A command from the controller board is not received.</p>	<ul style="list-style-type: none"> Loose connection Defective controller board Defective EGB <ol style="list-style-type: none"> Check the connection of the controller board. Replace the controller board. Replace the EGB
690 [D]	<p>EGB data error</p> <p>The data transfer in the EGB is interrupted by some incident (e.g. cover open etc.) during the data transfer.</p>	<ul style="list-style-type: none"> Defective EGB <ol style="list-style-type: none"> Replace the EGB.

Trouble-shooting

Controller Error

The following table shows the controller error codes. These codes show at these times if an error occurs:

- Power-on
- After the power-on self diagnostic test

Important: Always try turning the main switch off and on and check if the problem persists.



SC	Item	
	Symptom	Possible Cause/Required Action
818 [D]	[00FF] Watch-dog error	
	While the system program is running, other processes do not operate at all.	<ul style="list-style-type: none"> • Defective controller 1. Replace the controller if it occurs frequently.
819 [D]	[0696e] Kernel stop: Process error	
	System completely down	<ul style="list-style-type: none"> • Defective RAM DIMM • Defective SD card in slot 1 • Defective controller • Software error 1. Check and/or replace the RAM DIMM. 2. Check and/or replace the SD card in slot 1. 3. Replace the controller. 4. See NOTE at the end of the SC table.
	[0766d] Kernel stop: VM full error	
	Unexpected system memory size	<ul style="list-style-type: none"> • Defective RAM DIMM • Defective SD card in slot 1 • Defective controller • Software error 1. Check and/or replace the RAM DIMM. 2. Check and/or replace the SD card in slot 1. 3. Replace the controller. 4. See "NOTE" at the end of the SC table.
	[4361] Kernel stop: Cache error	
	Cache error in the CPU	<ul style="list-style-type: none"> • Defective CPU 1. Replace the controller board.
[----] Kernel stop: The others		
Error in OS	<ul style="list-style-type: none"> • Defective memory • Defective flash memory • Defective CPU 1. Replace the controller board.	

SC	Item	
	Symptom	Possible Cause/Required Action
820 [D]	[0001-0015] [000A-000D] Self-diagnostic error– CPU: Detailed error code	
	During the boot monitor program and self-diagnostic, any exception or cut-in are not supposed to happen. If these happen, it is defined as SC.	<ul style="list-style-type: none"> • Defective CPU device • Defective boot monitor program or self-diagnostic program <ol style="list-style-type: none"> 1. Replace the controller board. 2. Reinstall the system firmware.
	[00FF] Self-diagnostic error– CPU: Detailed error code	
	Cache access error in the CPU	<ul style="list-style-type: none"> • Defective CPU • Defective local bus <ol style="list-style-type: none"> 1. Turn the main switch off and on. 2. Reinstall the system program. 3. Replace the controller board.
	[0601, 0602, 0605, 0606, 0607, 0609] Self-diagnostic error– CPU: Detailed error code	
	Exceptional command does not operate even though it is executed on purpose.	<ul style="list-style-type: none"> • Defective CPU devices <ol style="list-style-type: none"> 1. Replace the controller board
	[060A-060E] Self-diagnostic error– CPU: Detailed error code	
	Cut-in command does not operate when it is executed.	<ul style="list-style-type: none"> • Defective CPU devices • Defective ASIC devices <ol style="list-style-type: none"> 1. Replace the controller board
	[0610] Self-diagnostic error– CPU: Detailed error code	
	Timer cut-in does not operate even though it is set.	<ul style="list-style-type: none"> • Defective CPU devices <ol style="list-style-type: none"> 1. Replace the controller board
	[0612] Self-diagnostic error– CPU: Detailed error code	
	Cut-in in ASIC occurs.	<ul style="list-style-type: none"> • Defective ASIC • Defective devices in which ASIC detects cut-in. <ol style="list-style-type: none"> 1. Replace the controller board.
	[06FF] Self-diagnostic error– CPU: Detailed error code	
	The pipeline clock frequency rate is different from the prescribed value.	<ul style="list-style-type: none"> • Defective CPU devices • Mode bit data error, which is used for initialising CPU <ol style="list-style-type: none"> 1. Replace the controller board
	[0702] Self-diagnostic error– CPU: Detailed error code	
	The result when the program is executed in the command cache is different from desirable value.	<ul style="list-style-type: none"> • Insufficient CPU cache • Insufficient memory process speed <ol style="list-style-type: none"> 1. Replace the controller board. 2. Replace the RAM DIMM.
[0709, 070A] Self-diagnostic error– CPU: Detailed error code		
Even you write the data in the only cache of memory, the data is actually written in another area of memory.	<ul style="list-style-type: none"> • Defective CPU devices • Incorrect SPD • Boot mode setting error <ol style="list-style-type: none"> 1. Replace the controller board. 2. Replace the RAM DIMM. 	

Trouble-shooting

SC	Item	
	Symptom	Possible Cause/Required Action
	[0801, 0804, 0807, 0808, 0809, 80A] Self-diagnostic error– CPU: Detailed error code	
	An error occurs when checking the TLB.	<ul style="list-style-type: none"> • Defective CPU devices <ol style="list-style-type: none"> 1. Replace the controller board.
	[4002-4005] Self-diagnostic error– CPU: Detailed error code	
	The calculation error in the CPU occurs.	<ul style="list-style-type: none"> • Defective CPU <ol style="list-style-type: none"> 1. Replace the CPU.
	[0B00] Self-diagnostic error - ASIC	
821 [D]	ASIC and CPU timer error detected during self-diagnostic.	<ul style="list-style-type: none"> • Defective controller <ol style="list-style-type: none"> 1. Replace the controller if the error is frequent.
	[0D05] Self-diagnostic error– ASIC	
	The CPU checks if the ASIC timer works properly compared with the CPU timer. If the ASIC timer does not function in the specified range, this SC code is displayed.	<ul style="list-style-type: none"> • System firmware problem • Defective RAM-DIMM • Defective controller <ol style="list-style-type: none"> 1. Reinstall the controller system firmware. 2. Replace the RAM-DIMM. 3. Replace the controller board.
822 [B]	[3003] Self-diagnostic error– HDD: Time out error	
	When the main switch is turned on or starting the self-diagnostic, the HDD stays busy for the specified time or more.	<ul style="list-style-type: none"> • Loose connection • Defective HDD • Defective controller <ol style="list-style-type: none"> 1. Check that the HDD is properly connected to the controller. 2. Replace the HDD. 3. Replace the controller.
	[3004] Self-diagnostic error– HDD: Command error	
	When the main switch is turned on or starting the self-diagnostic, the diagnostic error from HDD occurs.	<ul style="list-style-type: none"> • Defective HDD <ol style="list-style-type: none"> 1. Replace the HDD.
823 [B]	[6101] Self-diagnostic error – NIC: MAC address check sum error	
	The result of the MAC address check sum does not match the check sum stored in ROM.	<ul style="list-style-type: none"> • Defective controller <ol style="list-style-type: none"> 1. Replace the controller.
	[6104] Self-diagnostic error – NIC: PHY IC error	
	The PHY IC on the controller cannot be properly recognized.	Same as [6101]
	[6105] Self-diagnostic error – NIC: PHY IC loop back error	
	An error occurred during the loop-back test for the PHY IC on the controller.	Same as [6101]

SC	Item	
	Symptom	Possible Cause/Required Action
824 [D]	[1401] Self-diagnostic error – NVRAM	
	The controller cannot recognize the standard NVRAM installed or detects that the NVRAM is defective.	<ul style="list-style-type: none"> • Loose connection • Defective standard NVRAM • Defective controller <ol style="list-style-type: none"> 1. Check the standard NVRAM is firmly inserted into the socket. 2. Replace the NVRAM. 3. Replace the controller.
827 [D]	[0201] Self-diagnostic error – RAM: Verification error	
	Error detected during a write/verify check for the standard RAM (SRAM DIMM).	<ul style="list-style-type: none"> • Loose connection • Defective RAM DIMM • Defective controller <ol style="list-style-type: none"> 1. Replace the RAM DIMM. 2. Replace the controller.
828 [D]	[0101] Self-diagnostic error – ROM: Check sum error 1	
	The boot monitor and OS program stored in the ROM DIMM is checked. If the check sum of the program is incorrect, this SC code is displayed.	<ul style="list-style-type: none"> • Defective SD card in slot 1 • Defective controller <ol style="list-style-type: none"> 1. Replace the SD card in slot 1. 2. Replace the controller.
	[0104] Self-diagnostic error – ROM: Check sum error 2	
	All areas of the ROM DIMM are checked. If the check sum of all programs stored in the ROM DIMM is incorrect, this SC code is displayed.	Same as [0101]
829 [B]	[0302] Self-diagnostic error – RAM: Composition error (Slot 0)	
	The result of checking the composition data of the RAM in Slot 0 (CN5) on the controller is incorrect.	<ul style="list-style-type: none"> • Not specified RAM DIMM installed • Defective RAM DIMM <ol style="list-style-type: none"> 1. Replace the RAM DIMM. 2. Replace the controller board.
	[0401] Self-diagnostic error – RAM: Verification error (Slot 1)	
	The data stored in the RAM in Slot 1 does not match the data when reading.	Same as SC 829 [0302]
	[0402] Self-diagnostic error – RAM: Composition error (Slot 1)	
	The result of checking the composition data of the RAM in Slot 1 (CN6) on the controller is incorrect.	Same as SC 829 [0302]
850 [B]	Network interface error	
	The network is unusable.	<ul style="list-style-type: none"> • Defective controller <ol style="list-style-type: none"> 1. Replace the controller.

Trouble-shooting

SC	Item	
	Symptom	Possible Cause/Required Action
851 [B]	IEEE1394 interface error The 1394 interface is unusable.	<ul style="list-style-type: none"> • Defective IEEE1394 • Defective controller. <ol style="list-style-type: none"> 1. Replace the IEEE1394 interface board. 2. Replace the controller.
853 [B]	Wireless LAN card not detected The wireless LAN card is not detected before communication is established, though the wireless LAN board is detected.	<ul style="list-style-type: none"> • Loose connection <ol style="list-style-type: none"> 1. Check the connection.
854 [B]	Wireless LAN card not detected The wireless LAN card is not detected after communication is established, though the wireless LAN board is detected.	<ul style="list-style-type: none"> • Loose connection <ol style="list-style-type: none"> 1. Check the connection.
855 [B]	Wireless LAN card error An error is detected in the wireless LAN card.	<ul style="list-style-type: none"> • Loose connection • Defective wireless LAN card <ol style="list-style-type: none"> 1. Check the connection. 2. Replace the wireless LAN card.
856 [B]	Wireless LAN card error An error is detected in the wireless LAN board.	<ul style="list-style-type: none"> • Defective wireless LAN board • Loose connection <ol style="list-style-type: none"> 1. Check the connection. 2. Replace the wireless LAN board.
857 [B]	USB interface error The USB interface cannot be used due to a driver error.	<ul style="list-style-type: none"> • Defective USB driver • Loose connection <ol style="list-style-type: none"> 1. Check the connection. 2. Replace the controller.
860 [B]	HDD: Initialization error The controller detects that the hard disk fails.	<ul style="list-style-type: none"> • HDD not initialized • Defective HDD <ol style="list-style-type: none"> 1. Reformat the HDD. (SP5832) 2. Replace the HDD.
861 [D]	HDD: Reboot error The HDD does not become ready within 30 seconds after the power is supplied to the HDD.	<ul style="list-style-type: none"> • Loose connection • Defective cables • Defective HDD • Defective controller <ol style="list-style-type: none"> 1. Check the connection between the HDD and controller. 2. Check and replace the cables. 3. Replace the HDD. 4. Replace the controller.

SC	Item	
	Symptom	Possible Cause/Required Action
863 [D]	HDD: Read error The data stored in the HDD cannot be read correctly.	<ul style="list-style-type: none"> • Defective HDD • Defective controller <ol style="list-style-type: none"> 1. Replace the HDD. 2. Replace the controller.
864 [D]	HDD: CRC error While reading data from the HDD or storing data in the HDD, data transmission fails.	<ul style="list-style-type: none"> • Defective HDD <ol style="list-style-type: none"> 1. Replace the HDD.
865 [D]	HDD: Access error An error is detected while operating the HDD.	<ul style="list-style-type: none"> • Defective HDD <ol style="list-style-type: none"> 1. Replace the HDD.
866 [B]	SD card authentication error A correct license is not found in the SD card.	<ul style="list-style-type: none"> • SD-card data is corrupted. <ol style="list-style-type: none"> 1. Store correct data in the SD card.
867 [D]	SD card error The SD card is ejected from the slot.	<ul style="list-style-type: none"> • The SD card is ejected from the slot. <ol style="list-style-type: none"> 1. Install the SD card.
868 [D]	SD card access error [243-253: File system error, 254 or blank: Device error] SD card error occurs when SD card is activated.	<ul style="list-style-type: none"> • Defective SD card • Defective SD card controller <ol style="list-style-type: none"> 1. For a file system error, format the SD card on your PC. 2. For a device error, turn the mains switch off and on. 3. Replace the SD card. 4. Replace the controller.
870 [B]	Address data error An error is detected in the data copied to the address book over a network.	<ul style="list-style-type: none"> • Defective software program • Defective HDD • Incorrect path to the sever <ol style="list-style-type: none"> 1. Initialize the address book data (SP 5846 50). 2. Initialize the user information (format the hard disk with SP5832). 3. Replace the HDD.
900 [D]	Electric counter error Abnormal data is stored in the counters.	<ul style="list-style-type: none"> • Defective NVRAM • Defective controller <ol style="list-style-type: none"> 1. Turn the main switch off and on. 2. Check the connection between the NVRAM and controller. 3. Replace the NVRAM. 4. Replace the controller.
920 [B]	Printer function error The error that causes the malfunction in the software application is detected.	<ul style="list-style-type: none"> • Turn the main switch off/on, or install Printer Application firmware • Unexpected hardware structure (insufficient memory or hard disk space.)



SC	Item	
	Symptom	Possible Cause/Required Action
921 [B]	Printer font error No font is detected in the machines that have the font in the SD card when the printer application is run.	<ul style="list-style-type: none"> • Install the System, Printer Application, NIB, and Web System firmware.
990 [D]	Software performance error 1 The software makes an unexpected operation.	<ul style="list-style-type: none"> • Defective software • Defective controller • Software error <ol style="list-style-type: none"> 1. Reinstall the controller and/or engine main firmware. 2. See NOTE 1 at the end of the SC table.
991 [C]	Software performance error 2 Unexpected software error detected, which does not affect operation of the machine	The machine does not stop and the SC code is not displayed. The machine automatically recovers. However, the SC code is logged in the engine summary sheet (SMC).
992 [D]	SC not defined SC that is not controlled in the system occurs.	<ul style="list-style-type: none"> • Defective system software
998 [D]	Application start error No applications start within 60 seconds after the power is turned on.	<ul style="list-style-type: none"> • Loose connection of RAM-DIMM, SD card in slot 1 • Defective controller • Software problem <ol style="list-style-type: none"> 1. Check if the RAM-DIMM and SD card in slot 1 are properly connected. 2. Reinstall the controller system firmware. 3. Replace the controller.

NOTE 1: If a problem always occurs in a specific condition (for example. printer driver setting, image file), the problem may be caused by a software error. In this case, the following data and information needs to be sent back to your product specialist.

- Symptom / Possible Causes / Action taken
- Summary sheet (SP mode “1 Service/Printer SP”, SP 1004 [Print Summary])
- SMC - All (SP 5990 2)
- SMC - Logging (SP 5990 4)
- Printer driver settings used when the problem occurs
- All data displayed on the screen (SC code, error code, and program address where the problem is logged.)
- Image file which causes the problem, if possible

4.3 TROUBLESHOOTING GUIDE

NOTE: Remove the NVRAM from the original engine control board and install it on the new one when you replace the engine control board.

4.3.1 BLANK PRINT

Symptom	Possible cause	Necessary actions
No image is printed.	Defective LDU	Replace the LDU.
	Defective PCU	Replace the PCU.
	Defective transfer belt unit	Replace the transfer belt unit.
	Incorrect action of transfer roller	Check the guide and the transfer roller.
	Defective high voltage supply board	Replace high voltage supply board 1 or 2.
	Defective engine board (EGB)	Replace the engine board (EGB).

4.3.2 ALL-BLACK PRINT

Symptom	Possible cause	Necessary actions
All the paper is black.	Incorrectly installed PCU	Install the PCU correctly.
	Defective PCU	Replace the PCU.
	Defective high voltage supply board	Replace high voltage supply board 1 or 2.
	Defective LDU	Replace the LDU.
	Defective engine board (EGB)	Replace the engine board (EGB).
	Defective main board	Replace the main board.

4.3.3 MISSING CMY COLOR

Symptom	Possible cause	Necessary actions
C, M, or Y is missing.	Defective PCU	Replace the PCU.
	Loose connection between printer cartridge and engine board (EGB)	Replace the drum positioning cover. (☛3.2.1)
	Transfer belt not contacting PCU	Check the belt tension unit.
	Defective the color OPC motor	Replace the color OPC motor.
	Defective engine board (EGB)	Replace the engine board (EGB).

4.3.4 LIGHT PRINT

Symptom	Possible cause	Necessary actions
Printed images are too weak.	Loose connection between transfer roller and high voltage supply unit	Check the connection between the transfer roller and the high voltage supply unit.
	Dust in the laser beam path	Clean the laser beam path.
	Transfer belt not contacting PCU	Check the transfer unit.
	Defective PCU	Replace the PCU.
	Defective transfer roller	Repair the transfer roller.
	Defective fusing unit	Replace the fusing unit.
	Defective engine board (EGB)	Replace the engine board (EGB).

4.3.5 REPEATED SPOTS OR LINES ON PRINTS

Symptom	Possible cause	Necessary actions
The same spots or lines appear at regular intervals.		
At intervals of 35.0 mm (1.38 inches)	Defective charge roller	Replace the PCU.
At intervals of 35.8 mm (1.41 inches)	Defective OPC cleaning brush roller	Replace the PCU.
At intervals of 40.5 mm (1.59 inches)	Defective belt entrance roller	Replace the transfer belt unit.
At intervals of 41.1 mm (1.62 inches)	Defective belt transfer roller	Replace the transfer belt unit.
At intervals of 47.1 mm (1.86 inches)	Defective toner mixing auger	Replace the PCU.
At intervals of 56.5 mm (2.23 inches)	Defective development roller	Replace the PCU
At intervals of 72.8 mm (2.87 inches)	Defective belt tension roller	Replace the transfer belt unit.
At intervals of 82.2 mm (3.24 inches)	Defective transfer belt drive roller	Replace the transfer belt unit.
At intervals of 82.5 mm (3.25 inches)	Defective transfer roller	Replace the transfer roller.
At intervals of 94.2 mm (3.71 inches)	Defective OPC drum or pressure roller	Replace the PCU or the fusing unit
At intervals of 141.4 mm (5.57 inches)	Defective fusing belt	Replace the fusing unit.

Trouble-shooting

4.3.6 DARK VERTICAL LINE IN PRINT

Symptom	Possible cause	Necessary actions
A dark line appears. The line is parallel to the paper feed direction.		
Of one CMY color	Defective PCU	Replace the PCU.
Of any color (not C, M, or Y)	Dust in the laser beam path	Clean the laser beam path.
	Defective transfer belt unit	Replace the transfer belt unit.
	Defective fusing unit	Replace the fusing unit.

4.3.7 WHITE HORIZONTAL LINES OR BANDS

Symptom	Possible cause	Necessary actions
White lines or bands appear in images of all toner colors.	Defective PCU	Replace the PCU.
	Defective transfer belt unit	Replace the transfer belt unit.
	Defective transfer roller	Replace the transfer roller.

4.3.8 MISSING PARTS OF IMAGES

Symptom	Possible cause	Necessary actions
Some parts of images are missing.	Defective PCU	Replace the PCU.
	Defective transfer belt unit	Replace the transfer belt unit.
	Defective transfer roller	Replace the transfer roller.
	Defective fusing unit	Replace the fusing unit.

4.3.9 DIRTY BACKGROUND

Symptom	Possible cause	Necessary actions
Backgrounds are too dense.		
Of one CMYK color	Defective PCU	Replace the PCU.
Of more than one CMYK color	Defective high voltage supply board	Replace the high voltage supply board (1 or 2).

4.3.10 PARTIAL CMY COLOR DOTS

Symptom	Possible cause	Necessary actions
Unexpected dots of the same color appear at irregular intervals.	Defective PCU	Replace the PCU.
	Defective transfer belt unit	Replace the transfer belt unit.
	Defective fusing unit	Replace the fusing unit.

4.3.11 DARK IRREGULAR STREAKS ON PRINTS

Symptom	Possible cause	Necessary actions
Unexpected streaks appear at irregular intervals.	Defective transfer belt	Replace the transfer belt unit.

4.3.12 CMY COLOR IRREGULAR STREAKS

Symptom	Possible cause	Necessary actions
Unexpected streaks of the same color appear at irregular intervals.	Defective PCU	Replace the PCU.
	Defective transfer belt unit	Replace the transfer belt unit.

4.3.13 GHOSTING

Symptom	Possible cause	Necessary actions
The same or similar image appears two or more times. They get weaker and weaker.	Defective PCU	Replace the PCU.
	Defective transfer unit	Replace the transfer unit.

4.3.14 UNFUSED OR PARTIALLY FUSED PRINTS

Symptom	Possible cause	Necessary actions
Some parts of images are not fused very well.	Non-standard paper in use	Use recommended paper.
	Incorrect media type mode	Select an appropriate media mode.
	Defective fusing unit	Replace the fusing unit.

Trouble-shooting

4.3.15 IMAGE SKEW

Symptom	Possible cause	Necessary actions
Images are skewed	Incorrect installation of paper	Install the paper correctly.
	Incorrect paper guide position	Adjust the paper guide correctly.
	Defective registration roller	Repair the paper feed unit.
	Incorrect action of transfer roller	Check the transfer roller.
	Defective engine board (EGB)	Replace the engine board (EGB).
	Unclean separation pad	Clean the separation pad.
Defective spring	Replace the spring for the friction pad.	

4.3.16 BACKGROUND STAIN

Symptom	Possible cause	Necessary actions
The reverse side of the paper is not clean.	Unclean transfer roller	Clean the transfer roller.
	Unclean paper path	Clean the paper path.
	Unclean registration roller	Clean the registration roller.
	Unclean fusing unit exit	Clean the fusing unit exit.
	Defective fusing unit	Replace the fusing unit.

4.3.17 NO PRINTING ON PAPER EDGE

Symptom	Possible cause	Necessary actions
Images are not printed in the areas around the paper edges.	Defective PCU	Replace the PCU.
	Defective toner cartridge	Replace the toner cartridge.
	Defective transfer belt unit	Replace the transfer belt unit.
	Transfer belt not contacting PCU	Check the transfer unit.

4.3.18 IMAGE NOT CENTERED WHEN IT SHOULD BE

Symptom	Possible cause	Necessary actions
Images do not come to the center.	Incorrect installation of paper	Install the paper correctly.
	Incorrect paper guide position	Adjust the paper guide correctly.
	Incorrect margin setting	Adjust the margin setting.
	Defective engine control board	Replace the engine control board.

4.4 ELECTRICAL COMPONENT DEFECTS

4.4.1 SENSORS

No.	Sensor Name/ Sensor Board Name	Active	CN No./ Pin No.	Condition	Symptom
1	Color Drum Gear Position Sensor	H	CN222/2	Open	SC380
				Shorted	
2	Black Drum Gear Position Sensor	H	CN222/5	Open	SC380
				Shorted	
3	Toner End Sensor (K) Toner End Sensor (M) Toner End Sensor (C) Toner End Sensor (Y)	L	CN222/8 CN230/13 CN230/26 CN230/29	Open	Toner end cannot be detected.
				Shorted	Toner end is detected even if the there is enough toner.
				Open	
				Shorted	
4	Transfer Belt Contact Sensor	H	CN222/11	Open	SC442
				Shorted	
5	Transfer Roller Contact Sensor	L	CN222/14	Open	SC452
				Shorted	
6	TD Sensor (K) TD Sensor (M) TD Sensor (C) TD Sensor (Y)	A	CN222/20 CN225/4 CN230/4 CN230/20	Open	SC368 (K) SC369 (M)
				Shorted	SC370 (C) SC371 (Y)
8	Transfer Belt Rotation	L	CN222/27	Open	Automatic line position adjustment error: Transfer belt unit speed cannot be detected, causing the image skew.
				Shorted	
10	Front Door Sensor	H	CN206/1	Open	"Close Front/Left Cover" is displayed.
				Shorted	The front cover open cannot be detected.
11	Waste Toner Overflow Sensor	H	CN230/10	Open	Waste Toner near full is indicated.
				Shorted	Waste toner full cannot be detected even if the waste toner bottle is full.
12	Left Cover Sensor	H	C230/15	Open	"Close Front/Left Cover" is displayed.
				Shorted	The left cover open cannot be detected.
13	Temperature/Humidity Sensor	A A	CN231/1 CN231/3	Open	Printed image is wrong such as rough image, dirty background or weak image.
				Shorted	
14	Paper Size Sensor	L	CN214/17 CN214/15 CN214/14 CN214/13	Open	Paper size error
				Shorted	
15	Fusing Entrance Sensor	L	CN213/6	Open	Paper jam is not detected even if there is a paper
				Shorted	Paper jam is detected even if the there is no paper.
16	Duplex Jam Sensor 1	L	CN213/1	Open	Paper jam is not detected even if there is a paper
				Shorted	Paper jam is detected even if the there is no paper.

No.	Sensor Name/ Sensor Board Name	Active	CN No./ Pin No.	Condition	Symptom
17	Duplex Jam Sensor 2	L	CN213/3	Open	Paper jam is not detected even if there is a paper
				Short	Paper jam is detected even if there is no paper.
18	By-pass Paper Detection Sensor	L	CN211/22	Open	Paper is not detected on the by-pass tray
				Shorted	Paper is detected even if there is no paper on the by-pass tray.
19	By-pass Paper Size Sensor	L	CN211/17 CN211/16 CN211/20 CN211/19	Open	Paper size error
				Shorted	
20	Inverter Sensor	L	CN211/2	Open	Paper jam Z
				Shorted	
21	Fusing Exit Sensor	L	CN210/13	Open	Paper Jam A
				Shorted	
22	Paper Overflow Sensor	L	CN210/10	Open	The paper overflow message is not displayed even when a paper overflow condition exists, causing paper jam.
				Shorted	The paper overflow message is displayed.
23	Paper Exit Sensor	L	CN210/7	Open	Paper Jam A
				Shorted	
24	ID Sensors	A	CN209	Open	SC400/418
				Shorted	
25	Fusing Thermistor	A	CN209/1	Open	SC541
				Shorted	
26	Fusing Set Sensor	L	CN209/3 CN209/4	Open	"Reset Fusing Unit correctly" is displayed.
		L		Shorted	
27	Top Cover Sensor	H	CN208/2	Open	"Close Top Cover" is displayed.
				Shorted	The top cover open cannot be detected.
28	LDU Shutter Sensor	H	CN207/17	Open	SC270
				Shorted	
29	Registration Sensor	L	CN207/14	Open	Paper Jam A
				Shorted	
30	Paper Width Sensor	H	CN207/11	Open	Always, small paper is detected, causing printing speed down.
				Shorted	Small paper size does not detect.
31	Paper Height Sensor 1/2	H	CN207/5 CN207/8	Open	Remaining paper volume is wrong on Web Image Monitor.
				Shorted	
32	Paper End Sensor	H	CN2072	Open	The paper end detects even if paper is placed in the paper tray.
				Shorted	The paper end does not detect even if there is no paper in the paper tray, causing paper jam.

4.5 BLOWN FUSE CONDITIONS

Power supply unit

Fuse	Rating		Symptom when turning on the main switch
	115V	220V-240V	
FU1	15A/125V	8A/250V	No response.
FU2	8A/125V	4A/250V	No response.
FU3	1A/250V	1A/250V	Tray Heater does not turn on.
FU4	4A/250V	4A/250V	No display.
FU5	6.3A/250V	6.3A/250V	SC270 is displayed.
FU6	6.3A/250V	6.3A/250V	SC270 is displayed.

IOB

Fuse	Rating	Symptom when turning on the main switch
FU897	3.15A	Optional Paper Tray Unit dose not work.
FU898	2.0A	Toners are not supplied.
FU899	1.6A	SC270 is displayed.

4.6 LEDS

No LEDs are used for this model (except for the Network Interface).

5. SERVICE TABLES

5.1 SERVICE PROGRAM MODE

⚠ CAUTION

Before accessing the service menu, do the following:

Confirm that there is no print data in the printer buffer (the Data In LED must not be lit or blinking).

If there is some data in the buffer, wait until all data has been printed.

5.1.1 SERVICE MODE OPERATION

NOTE: The Service Program Mode is for use by service representatives only so that they can properly maintain product quality. If this mode is used by anyone other than service representatives for any reason, data might be deleted or settings might be changed. In such case, product quality cannot be guaranteed any more.

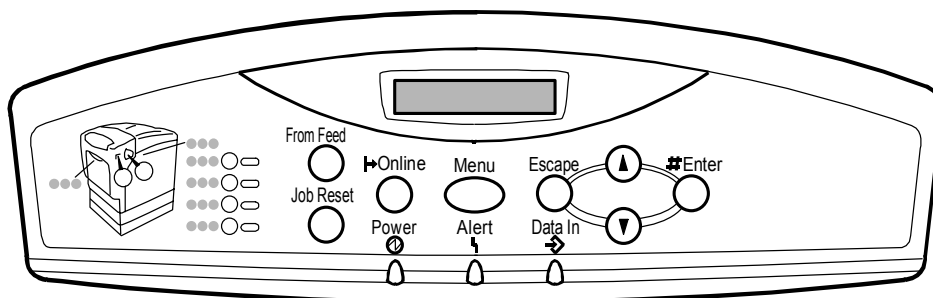

G105S902.WMF

Service
Tables

Entering the Service Mode

There are two ways to enter the service mode.

Method 1: Turn the machine on while pressing the “On Line” key and “Escape” key together until “SYSTEMver x.xx/ 1. Service” shows on the display.

NOTE: If you switch the machine off, any jobs stored on the hard disk using the sample print and protected print features will be deleted. Check first with the user tools to see if there are any jobs stored with these features (Menu key - Sample Print, or Protected Print).

Method 2: Press the “Up/Down arrow” keys together for about 5 seconds, then press the “Enter” key.

The “SYSTEMver x.xx/ 1. Service” appears on the display.

NOTE: The machine automatically goes off line when you enter the service mode.

Accessing the Required Program

Use the “Up/Down arrow” keys to scroll through the menu listing.

1. Service Menu: Controller service modes
2. Engine Maintenance: Engine service modes
- 3: End: Exit service mode

To select an item, press the “Enter” key. Then the sub-menu will appear.

Scroll through the sub menu items using the “Up/Down arrow” keys.

To go back to a higher level, press the “Escape” key.

Inputting a Value or Setting for a Service Program

Enter the required program mode as explained above. The setting appearing on the display is the current setting.

Select the required setting using the “Up/Down arrow” keys, then press the “Enter” key. The previous value remains if the “Enter” key is not pressed.

Exiting Service Mode

Select “3. End” from the service mode main menu, then press the “Enter” key.

NOTE: To make the settings effective, turn the main switch off and on after exiting service mode.

5.1.2 REMARKS

Display on the Control Panel Screen

Since the maximum number of characters which can be displayed on the control panel screen is limited (14 or 16 characters), the description of SP modes displayed on the screen needs to be abbreviated. The following are the major abbreviations used for the SP modes for which the full description is over 14 or 16 characters.

Paper Type

N: Plain paper 1, N2 or Normal 2: Plain paper 2 (plain & recycled)
 TC: Thick paper, Thick 1: Thick paper 1, Thick 2: Thick paper 2
 TN: Thin paper
 SP: Special paper

Color Mode [Color]

[K]: Black in B&W mode
 [Y], [M], or [C]: Yellow, Magenta, or Cyan in Full Color mode
 [YMC]: Only for Yellow, Magenta, and Cyan
 [FC], [CI]: Full Color mode
 [FC, K], [FC, Y], [FC, M], or [FC, C]: Black, Yellow, Magenta, or Cyan in full color mode

Process Speed

LS: Low speed xx
 RS: Regular speed xxx
 HS: High speed xxx

As shown in the following table, the process speed (mm/s) depends on the print mode (B&W or Color), resolution, and/or type of paper selected. Some SP mode settings depend on the process speed.

Mode	Resolution (dpi)	Line speed (mm/s)	Print speed (ppm)
B/W	600 x 600	155	25
	1,200 x 600		
Color	1,200 x 1,200	77.5	12.5
	600 x 600	155	25
	1,200 x 600		
OHP/Thick	1,200 x 1,200	77.5	12.5
	600 x 600	77.5	12.5
	1,200 x 600		
	1,200 x 1,200		

Count Unit

R: Rotation
 S: Prints

Environment

LL: Low temperature and Low humidity
ML: Medium temperature and Low humidity
MM: Medium temperature and Medium humidity
MH: Medium temperature and High humidity
HH: High temperature and High humidity

Others

The following symbols are used in the SP mode tables.

FA: Factory setting

(Data may be adjusted from the default setting at the factory.)

DFU: Design/Factory Use only

Do not touch the SP mode in the field.

“P” in the right hand side of the mode number column means that this SP mode relates to the Printer Controller. If “P” is not in the column, this SP mode relates to the Printer Engine.

A sharp (#) to the right hand side of the mode number column means that the main switch must be turned off and on to effect the setting change.

An asterisk (*) to the right hand side of the mode number column means that this mode is stored in the NVRAM (Engine and Printer Controller). If you do a RAM clear, this SP mode will be reset to the default value. “EGB”, “CTL” and “NV” indicate which NVRAM contains the data.

- EGB: NVRAM on the EGB board
- CTL: NVRAM on the controller board
- NV: NVRAM on the NVRAM expansion board (user account enhancement kit)

The settings of each SP mode are explained in the right-hand column of the SP table in the following manner.

[Adjustable range / **Default setting** / Step] Alphanumeric

NOTE: If “Alphanumeric” is written to the right of the bracket as shown above, the setting of the SP mode is displayed on the screen using alphanumeric characters instead of only numbers. However, the settings in the bracket in the SP mode table are explained by using only the numbers.

5.1.3 BIT SWITCH PROGRAMMING

Do not change the bit switches unless you are told to do this by the manufacturer.

1. Start the SP mode. The “Service” menu is shown.
2. Press the enter key two times.
3. To select a bit switch, press the up arrow key or the down arrow key.
4. Push the enter key.
5. Set the value with these keys:
 - [Up] [Down]: Moves the cursor to one of the adjacent bits.
 - [Escape]: Goes out of the program without saving changes.
 - [Enter]: Goes out of the program and saves changes.

NOTE: The digit at the left [A] is bit 7 and the digit at the right [B] is bit 0.

Sw#1	00000000
bit0	—

6. Push the escape key one or more times until the menu “Service” is shown.
7. Select “End” and push the enter key.

5.2 SERVICE MODE TABLE

5.2.1 CONTROLLER SERVICE MODE

1001	[Bit Switch]		
1001 001	Bit Switch 1	*CTL	Adjusts bit switch settings. DFU
1001 002	Bit Switch 2	*CTL	Bit 0 to 2: Not used. Do not change settings. Bit 3: Changing print language (PCL <-> PS) 0: Enabled 1: Disabled (No change) Bit 4 to 7: Not used. Do not change settings.
1001 003	Bit Switch 3	*CTL	Bit 0: PostScript3 Euro glyph 0: Disabled 1: Enabled (Even if there is no Euro Glyph in ROM, it is possible to load the Euro Glyph data.) Bit 1: Not used. Do not change setting. Bit 2:PCL5e/5c (HP4000/HP8000) The left space command is set to "0", the machine is changed to "1" 0: Disabled 1: Enabled Bit 3: PCL5e/GL2: pen # of PW 0: Normal 1: Patch Bit 4: Tray selecting 0: Select tray is determined auto tray selecting 1: Like HP/SV Bit 5 to 7: Not used. Do not change settings.
1001 004	Bit Switch 4	*CTL	Adjusts bit switch settings. DFU
1001 005	Bit Switch 5	*CTL	Bit 0 to 2: Not used. Do not change settings. Bit 3: Enabled the "%%" command of the PostScript detection condition for the auto print language selection function. 0: Enabled 1: Disabled Bit 4 to 7: Not used. Do not change settings.
1001 006	Bit Switch 6	*CTL	Adjusts bit switch settings. DFU
1001 007	Bit Switch 7	*CTL	
1001 008	Bit Switch 8	*CTL	
1001 009	Bit Switch 9	*CTL	
1001 010	Bit Switch A	*CTL	

1001 011	Bit Switch B	*CTL	
1001 012	Bit Switch C	*CTL	
1001 013	Bit Switch D	*CTL	
1001 014	Bit Switch E	*CTL	
1001 015	Bit Switch F	*CTL	
1001 016	Bit Switch G	*CTL	

1003	[Clear Setting]		
1003 001	Init. System		Initializes settings in the System menu of the user mode.
1003 003	Delete Program		DFU

1004	[Print Summary]		
1004 001	Print Summary 1		Prints the service summary sheet (a summary of all the controller settings).
1004 002	Print Summary 2		Prints the service summary sheet (a summary of all the controller settings and debug information). FA

1005	[Disp. Version]		
	Displays the version of the controller firmware.		

1101	[ToneCtlSet]		
1101 001	Tone (Factory)	*CTL	Recalls a set of gamma settings. This can be either a) the factory setting, b) the previous setting, or c) the current setting.
1101 002	Tone (Prev.)	*CTL	
1101 003	Tone (Current)	*CTL	

1102	[ToneCtlSet]	*CTL	
	Sets the printing mode (resolution) for the printer gamma adjustment. The asterisk (*) shows which mode is set.		
	<ul style="list-style-type: none"> • *1200x1200Photo • 600x600Text • 1200x600Text • 600x600Photo • 1200x600Photo 		

1103	[PrnColorSheet]		
1103 001	ToneCtlSheet		Prints the test page to check the color balance before and after the gamma adjustment.
1103 002	ColorChart		

Service Tables

1104	[ToneCtlValue]		
	Adjusts the printer gamma for the mode selected in the Mode Selection menu.		
1104 001	Set Black 1	*CTL	[0 to 255 / 16 / 1/step]
1104 021	Set Cyan 1	*CTL	
1104 041	Set Magenta 1	*CTL	
1104 061	Set Yellow 1	*CTL	
1104 002	Set Black 2	*CTL	[0 to 255 / 32 / 1/step]
1104 022	Set Cyan 2	*CTL	
1104 042	Set Magenta 2	*CTL	
1104 062	Set Yellow 2	*CTL	
1104 003	Set Black 3	*CTL	[0 to 255 / 48 / 1/step]
1104 023	Set Cyan 3	*CTL	
1104 043	Set Magenta 3	*CTL	
1104 063	Set Yellow 3	*CTL	
1104 004	Set Black 4	*CTL	[0 to 255 / 64 / 1/step]
1104 024	Set Cyan 4	*CTL	
1104 044	Set Magenta 4	*CTL	
1104 064	Set Yellow 4	*CTL	
1104 005	Set Black 5	*CTL	[0 to 255 / 80 / 1/step]
1104 025	Set Cyan 5	*CTL	
1104 045	Set Magenta 5	*CTL	
1104 065	Set Yellow 5	*CTL	
1104 006	Set Black 6	*CTL	[0 to 255 / 96 / 1/step]
1104 026	Set Cyan 6	*CTL	
1104 046	Set Magenta 6	*CTL	
1104 066	Set Yellow 6	*CTL	
1104 007	Set Black 7	*CTL	[0 to 255 / 112 / 1/step]
1104 027	Set Cyan 7	*CTL	
1104 047	Set Magenta 7	*CTL	
1104 067	Set Yellow 7	*CTL	
1104 008	Set Black 8	*CTL	[0 to 255 / 128 / 1/step]
1104 028	Set Cyan 8	*CTL	
1104 048	Set Magenta 8	*CTL	
1104 068	Set Yellow 8	*CTL	
1104 009	Set Black 9	*CTL	[0 to 255 / 144 / 1/step]
1104 029	Set Cyan 9	*CTL	
1104 049	Set Magenta 9	*CTL	
1104 069	Set Yellow 9	*CTL	
1104 010	Set Black 10	*CTL	[0 to 255 / 160 / 1/step]
1104 030	Set Cyan 10	*CTL	
1104 050	Set Magenta 10	*CTL	
1104 070	Set Yellow 10	*CTL	
1104 011	Set Black 11	*CTL	[0 to 255 / 176 / 1/step]
1104 031	Set Cyan 11	*CTL	
1104 051	Set Magenta 11	*CTL	
1104 071	Set Yellow 11	*CTL	
1104 012	Set Black 12	*CTL	[0 to 255 / 192 / 1/step]
1104 032	Set Cyan 12	*CTL	
1104 052	Set Magenta 12	*CTL	

1104 072	Set Yellow 12	*CTL	
1104 013	Set Black 13	*CTL	[0 to 255 / 208 / 1/step]
1104 033	Set Cyan 13	*CTL	
1104 053	Set Magenta 13	*CTL	
1104 073	Set Yellow 13	*CTL	
1104 014	Set Black 14	*CTL	[0 to 255 / 224 / 1/step]
1104 034	Set Cyan 14	*CTL	
1104 054	Set Magenta 14	*CTL	
1104 074	Set Yellow 14	*CTL	
1104 015	Set Black 15	*CTL	[0 to 255 / 240 / 1/step]
1104 035	Set Cyan 15	*CTL	
1104 055	Set Magenta 15	*CTL	
1104 075	Set Yellow 15	*CTL	

1105	[ToneCtlSave]		
	Saves the print gamma (adjusted with the Gamma Adj.) as the new Current Setting. Before the machine stores the new “current setting”, it moves the data stored as the “current setting” to the “previous setting” memory-storage location.		

1106	[Toner Limit]		
	Adjusts the maximum toner amount for image development.		
1106 001	TonerLimitPhot	*CTL	[100 to 400 / 260 / 1 %/step]
1106 002	TonerLimitText	*CTL	[100 to 400 / 200 / 1 %/step]

1107	[FactoryTestPrt]		
	Prints the test page to check the color balance before transportation (600 x 600 2 bit). DFU		

1108	[Ext. Toner Save]		
1108 001	Mode 1: Text		DFU
1108 002	Mode 2: Text		
1108 003	Mode 1: Image		
1108 004	Mode 2: Image		
1108 005	Mode 1: Line		
1108 006	Mode 2: Line		
1108 007	Mode 1: paint		
1108 008	Mode 2: Paint		

Service Tables

5.2.2 ENGINE SERVICE MODE

SP1-XXX (Feed)

1001	<p>[Lead Edge Reg.] Leading Edge Registration (Tray or By-pass, Paper Type, Process Speed) Paper Type ->N: Plain paper 1, N2 or Normal 2: Plain paper 2, Thick2: Thick paper 2 (see the Specifications table for details on these paper weights) Process Speed: LS: Low speed, RS: Regular speed</p>		
	<p>Adjusts the leading edge registration. This SP changes the registration clutch operation timing for each mode. +value sets the registration start timing earlier. -value sets the registration start timing later. NOTE: The value of the normal paper in RS is the standard value. The values of papers other than normal are added to the value of the normal paper in RS.</p>		
1001 001	Tray 1: Normal: LS	*EGB	[-10.0 to 10.0 / 0.0 / 0.1 mm/step]
1001 002	Tray 1: Normal: RS	*EGB	[-10.0 to 10.0 / -3.0 / 0.1 mm/step]
1001 003	Tray 1: Thick	*EGB	[-10.0 to 10.0 / 1.5 / 0.1 mm/step]
1001 004	Tray 1: OHP	*EGB	[-10.0 to 10.0 / 0.0 / 0.1 mm/step]
1001 005	Tray 2: Normal: LS	*EGB	[-10.0 to 10.0 / 0.0 / 0.1 mm/step]
1001 006	Tray 2: Normal: RS	*EGB	[-10.0 to 10.0 / -3.0 / 0.1 mm/step]
1001 007	Tray 2: Thick	*EGB	[-10.0 to 10.0 / 1.5 / 0.1 mm/step]
1001 008	Tray 2: OHP	*EGB	[-10.0 to 10.0 / 0.0 / 0.1 mm/step]
1001 009	Tray 3: Normal: LS	*EGB	[-10.0 to 10.0 / 0.0 / 0.1 mm/step]
1001 010	Tray 3: Normal: RS	*EGB	[-10.0 to 10.0 / -3.0 / 0.1 mm/step]
1001 011	Tray 3: Thick	*EGB	[-10.0 to 10.0 / 1.5 / 0.1 mm/step]
1001 012	Tray 3: OHP	*EGB	[-10.0 to 10.0 / 0.0 / 0.1 mm/step]
1001 013	By-pass: N: LS	*EGB	[-10.0 to 10.0 / 0.0 / 0.1 mm/step]
1001 014	By-pass: N: RS	*EGB	[-10.0 to 10.0 / -3.0 / 0.1 mm/step]
1001 015	By-pass: Thick	*EGB	[-10.0 to 10.0 / 1.5 / 0.1 mm/step]
1001 016	By-pass: OHP	*EGB	[-10.0 to 10.0 / 0.0 / 0.1 mm/step]
1001 017	Duplex: Normal: LS	*EGB	[-10.0 to 10.0 / 0.0 / 0.1 mm/step]
1001 018	Duplex: Normal: RS	*EGB	[-10.0 to 10.0 / -3.0 / 0.1 mm/step]
1001 019	Duplex: Thick	*EGB	[-10.0 to 10.0 / 1.0 / 0.1 mm/step]
1001 020	Duplex: N2: LS	*EGB	[-10.0 to 10.0 / 1.0 / 0.1 mm/step]
1001 021	Duplex: N2: RS	*EGB	[-10.0 to 10.0 / 1.0 / 0.1 mm/step]
1001 022	Tray 1: Normal 2: LS	*EGB	[-10.0 to 10.0 / 1.0 / 0.1 mm/step]
1001 023	Tray 1: Normal 2: RS	*EGB	[-10.0 to 10.0 / 1.0 / 0.1 mm/step]
1001 024	Tray 1: Thick 2	*EGB	[-10.0 to 10.0 / 1.5 / 0.1 mm/step]
1001 025	Tray 1: Thin: LS	*EGB	[-10.0 to 10.0 / 0.0 / 0.1 mm/step]
1001 026	Tray 1: Thin: RS	*EGB	[-10.0 to 10.0 / 0.0 / 0.1 mm/step]
1001 027	Tray 1: Special	*EGB	[-10.0 to 10.0 / 1.5 / 0.1 mm/step]
1001 028	Tray 2: Normal 2: LS	*EGB	[-10.0 to 10.0 / 1.0 / 0.1 mm/step]
1001 029	Tray 2: Normal 2: RS	*EGB	[-10.0 to 10.0 / 1.0 / 0.1 mm/step]
1001 030	Tray 2: Thick 2	*EGB	[-10.0 to 10.0 / 1.5 / 0.1 mm/step]
1001 031	Tray 2: Thin: LS	*EGB	[-10.0 to 10.0 / 0.0 / 0.1 mm/step]
1001 032	Tray 2: Thin: RS	*EGB	[-10.0 to 10.0 / 0.0 / 0.1 mm/step]
1001 033	Tray 2: Special	*EGB	[-10.0 to 10.0 / 1.5 / 0.1 mm/step]
1001 034	Tray 3: Normal 2: LS	*EGB	[-10.0 to 10.0 / 1.0 / 0.1 mm/step]

1001 035	Tray 3: Normal 2: RS	*EGB	[-10.0 to 10.0 / 1.0 / 0.1 mm/step]
1001 036	Tray 3: Thick 2	*EGB	[-10.0 to 10.0 / 1.5 / 0.1 mm/step]
1001 037	Tray 3: Thin: LS	*EGB	[-10.0 to 10.0 / 0.0 / 0.1 mm/step]
1001 038	Tray 3: Thin: RS	*EGB	[-10.0 to 10.0 / 0.0 / 0.1 mm/step]
1001 039	Tray 3: Special	*EGB	[-10.0 to 10.0 / 1.5 / 0.1 mm/step]
1001 040	By-pass: N2: LS	*EGB	[-10.0 to 10.0 / 1.0 / 0.1 mm/step]
1001 041	By-pass: N2: RS	*EGB	[-10.0 to 10.0 / 1.0 / 0.1 mm/step]
1001 042	By-pass: Thick 2	*EGB	[-10.0 to 10.0 / 1.5 / 0.1 mm/step]
1001 043	By-pass: Thin: LS	*EGB	[-10.0 to 10.0 / 0.0 / 0.1 mm/step]
1001 044	By-pass: Thin: RS	*EGB	[-10.0 to 10.0 / 0.0 / 0.1 mm/step]
1001 045	By-pass: Special	*EGB	[-10.0 to 10.0 / 1.5 / 0.1 mm/step]

1002	[S-to-S Reg.] Side-to-Side Registration		
1002 001	By-pass	*EGB	Adjusts the side-to-side registration for each mode. This SP changes the laser main scan start position. [-10.0 to 10.0 / 0.0 / 0.1 mm/step]
1002 002	Tray 1	*EGB	
1002 003	Tray 2	*EGB	
1002 004	Tray 3	*EGB	
1002 005	Duplex	*EGB	

1003	[Paper Buckle] Paper Buckle (Tray or By-pass, Paper Type, Process Speed) Paper Type ->N: Plain paper 1, N2 or Normal 2: Plain paper 2, Thick2: Thick paper 2 (see the Specifications table for details on these paper weights) Process Speed-> LS: Low speed, RS: Regular speed		
1003 001	Tray 1: Normal: LS	*EGB	Adjusts the amount of paper buckle at the registration roller for each mode. This SP changes the paper feed timing. [-10.0 to 10.0 / 0.0 / 0.1 mm/step]
1003 002	Tray 1: Normal: RS	*EGB	
1003 003	Tray 1: Thick	*EGB	
1003 004	Tray 1: OHP	*EGB	
1003 005	Tray 2: Normal: LS	*EGB	
1003 006	Tray 2: Normal: RS	*EGB	
1003 007	Tray 2: Thick	*EGB	
1003 008	Tray 2: OHP	*EGB	
1003 009	Tray 3: Normal: LS	*EGB	
1003 010	Tray 3: Normal: RS	*EGB	
1003 011	Tray 3: Thick	*EGB	
1003 012	Tray 3: OHP	*EGB	
1003 013	By-pass: N:LS	*EGB	
1003 014	By-pass: N:RS	*EGB	
1003 015	By-pass: Thick	*EGB	
1003 016	By-pass: OHP	*EGB	
1003 017	Duplex: Normal: LS	*EGB	
1003 018	Duplex: Normal: RS	*EGB	
1003 019	Duplex: Thick	*EGB	
1003 020	Duplex: N2: LS	*EGB	
1003 021	Duplex: N2: RS	*EGB	
1003 022	Tray 1: Normal 2: LS	*EGB	
1003 023	Tray 1: Normal 2: RS	*EGB	
1003 024	Tray 1: Thick 2	*EGB	

1003 025	Tray 1: Thin: LS	*EGB	
1003 026	Tray 1: Thin: RS	*EGB	
1003 027	Tray 1: Special	*EGB	
1003 028	Tray 2: Normal 2: LS	*EGB	
1003 029	Tray 2: Normal 2: RS	*EGB	
1003 030	Tray 2: Thick 2	*EGB	
1003 031	Tray 2: Thin: LS	*EGB	
1003 032	Tray 2: Thin: RS	*EGB	
1003 033	Tray 2: Special	*EGB	
1003 034	Tray 3: Normal 2: LS	*EGB	
1003 035	Tray 3: Normal 2: RS	*EGB	
1003 036	Tray 3: Thick 2	*EGB	
1003 037	Tray 3: Thin: LS	*EGB	
1003 038	Tray 3: Thin: RS	*EGB	
1003 039	Tray 3: Special	*EGB	
1003 040	By-pass: N2: LS	*EGB	
1003 041	By-pass: N2: RS	*EGB	
1003 042	By-pass: Thick 2	*EGB	
1003 043	By-pass: Thin: LS	*EGB	
1003 044	By-pass: Thin: RS	*EGB	
1003 045	By-pass: Special	*EGB	

1004	[Mt Speed] Drive Motor Speed		DFU
	(Unit, Process Speed, Paper Type) Paper Type ->N: Plain paper 1, N2 or Normal 2: Plain paper 2, Thick2: Thick paper 2 (see the Specifications table for details on these paper weights) Process Speed-> LS: Low speed, RS: Regular speed CW: Clockwise, CCW: Counterclockwise PFU: Optional paper tray unit		
1004 001	DEV / OPC [K]: LS	*EGB	Adjusts the black development and OPC motor speed. [-4.00 to 4.00 / -1.35 / 0.01 %/step]
1004 002	DEV / OPC [K]: RS	*EGB	
1004 003	DEV [CMY]: LS	*EGB	Adjusts the color development motor speed. [-4.00 to 4.00 / 0.0 / 0.01%/step]
1004 004	DEV [CMY]: RS	*EGB	
1004 005	OPC [CMY]: LS	*EGB	Adjusts the color OPC motor speed. [-4.00 to 4.00 / -1.35 / 0.01%/step]
1004 006	OPC [CMY]: RS	*EGB	
1004 007	Fusing: LS	*EGB	Adjusts the paper exit and fusing motor speed. [-4.00 to 4.00 / 1.4 / 0.01%/step]
1004 008	Fusing: RS	*EGB	
1004 009	Transfer Belt: LS	*EGB	Adjusts the transfer belt motor speed. [-4.00 to 4.00 / 0.0 / 0.01%/step]
1004 010	Transfer Belt: RS	*EGB	
1004 011	PFU: LS	*EGB	Adjusts the speed of the feed motor in the optional paper tray unit. [-4.00 to 4.00 / -0.36 / 0.01%/step]
1004 012	PFU: RS	*EGB	
1004 013	Duplex: LS: Add	*EGB	Adjusts the duplex motor speed. [-4.00 to 4.00 / 0.0 / 0.01%/step]
1004 014	Duplex: RS: Add	*EGB	
1004 015	Duplex: LS	*EGB	Adjusts the duplex motor speed. [-4.00 to 4.00 / -0.36 / 0.01%/step]
1004 016	Duplex: RS	*EGB	
1004 017	Reverse: LS: CW	*EGB	Adjusts the inverter motor speed.

1004 018	Reverse: RS: CW	*EGB	[-4.00 to 4.00 / 1.4 / 0.01%/step]
1004 019	Reverse: LS: CCW	*EGB	Adjusts the inverter motor speed.
1004 020	Reverse: RS: CCW	*EGB	[-4.00 to 4.00 / 0.0 / 0.01%/step]
1004 021	DEV / OPC [K]: LS: N2	*EGB	Adjusts the black development and OPC motor speed.
1004 022	DEV / OPC [K]: RS: N2	*EGB	[-4.00 to 4.00 / -1.35 / 0.01%/step]
1004 023	DEV [CMY]: LS: N2	*EGB	Adjusts the color development motor speed.
1004 024	DEV [CMY]: RS: N2	*EGB	[-4.00 to 4.00 / 0.0 / 0.01%/step]
1004 025	OPC [CMY]: LS: N2	*EGB	Adjusts the color OPC motor speed.
1004 026	OPC [CMY]: RS: N2	*EGB	[-4.00 to 4.00 / -1.35 / 0.01%/step]
1004 027	Fusing: LS: N2	*EGB	Adjusts the paper exit and fusing motor speed.
1004 028	Fusing: RS: N2	*EGB	[-4.00 to 4.00 / 0.6 / 0.01%/step]
1004 029	Trans. Belt: LS: N2	*EGB	Adjusts the transfer belt motor speed.
1004 030	Trans. Belt: RS: N2	*EGB	[-4.00 to 4.00 / 0.0 / 0.01%/step]
1004 031	PFU: LS: Normal 2	*EGB	Adjusts the speed of the feed motor in the optional paper tray unit.
1004 032	PFU: RS: Normal 2	*EGB	[-4.00 to 4.00 / -1.14 / 0.01%/step]
1004 033	Duplex: LS: Add: N2	*EGB	Adjusts the duplex motor speed.
1004 034	Duplex: RS: Add: N2	*EGB	[-4.00 to 4.00 / 0.0 / 0.01%/step]
1004 035	Duplex: LS: N2	*EGB	Adjusts the duplex motor speed.
1004 036	Duplex: RS: N2	*EGB	[-4.00 to 4.00 / -0.36 / 0.01%/step]
1004 037	Reverse: LS: CW: N2	*EGB	Adjusts the inverter motor speed.
1004 038	Reverse: RS: CW: N2	*EGB	[-4.00 to 4.00 / 0.6 / 0.01%/step]
1004 039	Rever.: LS: CCW: N2	*EGB	Adjusts the inverter motor speed.
1004 040	Rever.: RS: CCW: N2	*EGB	[-4.00 to 4.00 / 0.0 / 0.01%/step]
1004 041	DEV / OPC [K]: LS: TC	*EGB	Adjusts the black development and OPC motor speed.
			[-4.00 to 4.00 / -1.35 / 0.01%/step]
1004 042	DEV [CMY]: LS: TC	*EGB	Adjusts the color development motor speed.
			[-4.00 to 4.00 / 0.0 / 0.01%/step]
1004 043	OPC [CMY]: LS: TC	*EGB	Adjusts the color OPC motor speed.
			[-4.00 to 4.00 / -1.35 / 0.01%/step]
1004 044	Fusing: LS: Thick	*EGB	Adjusts the paper exit and fusing motor speed.
			[-4.00 to 4.00 / 0.6 / 0.01%/step]
1004 045	Trans. Belt: LS: TC	*EGB	Adjusts the transfer belt motor speed.
			[-4.00 to 4.00 / 0.0 / 0.01%/step]
1004 046	PFU: LS: Thick	*EGB	Adjusts the speed of the feed motor in the optional paper tray unit.
			[-4.00 to 4.00 / -1.14 / 0.01%/step]
1004 047	Duplex: LS: Add: TC	*EGB	Adjusts the duplex motor speed.
			[-4.00 to 4.00 / 0.0 / 0.01%/step]
1004 048	Duplex: LS: Thick	*EGB	Adjusts the duplex motor speed.
			[-4.00 to 4.00 / -0.36 / 0.01%/step]
1004 049	Reverse: LS: CW: TC	*EGB	Adjusts the inverter motor speed.
			[-4.00 to 4.00 / 0.6 / 0.01%/step]
1004 050	Rever.: LS: CCW: TC	*EGB	Adjusts the inverter motor speed.
			[-4.00 to 4.00 / 0.0 / 0.01%/step]

1004 051	DEV / OPC [K] LS:TC2	*EGB	Adjusts the black development and OPC motor speed. [-4.00 to 4.00 / -1.35 / 0.01%/step]
1004 052	DEV [CMY]: LS: TC2	*EGB	Adjusts the color development motor speed. [-4.00 to 4.00 / 0.0 / 0.01%/step]
1004 053	OPC [CMY]: LS: TC2	*EGB	Adjusts the color OPC motor speed. [-4.00 to 4.00 / -1.35 / 0.01%/step]
1004 054	Fusing: LS: TC 2	*EGB	Adjusts the paper exit and fusing motor speed. [-4.00 to 4.00 / 0.6 / 0.01%/step]
1004 055	T. Belt: LS: TC 2	*EGB	Adjusts the transfer belt motor speed. [-4.00 to 4.00 / 0.0 / 0.01%/step]
1004 056	PFU: LS: Thick 2	*EGB	Adjusts the speed of the feed motor in the optional paper tray unit. [-4.00 to 4.00 / -1.14 / 0.01%/step]
1004 057	Duplex: LS: Thick 2	*EGB	Adjusts the duplex motor speed. [-4.00 to 4.00 / -0.36 / 0.01%/step]
1004 058	DEV / OPC [K]: LS: SP	*EGB	Adjusts the black development and OPC motor speed. [-4.00 to 4.00 / -1.35 / 0.01%/step]
1004 059	DEV [CMY]: LS: SP	*EGB	Adjusts the color development motor speed. [-4.00 to 4.00 / 0.0 / 0.01%/step]
1004 060	OPC [CMY]: LS: SP	*EGB	Adjusts the color OPC motor speed. [-4.00 to 4.00 / -1.35 / 0.01%/step]
1004 061	Fusing: LS: SP	*EGB	Adjusts the paper exit and fusing motor speed. [-4.00 to 4.00 / 0.6 / 0.01%/step]
1004 062	Trans. Belt: LS: SP	*EGB	Adjusts the transfer belt motor speed. [-4.00 to 4.00 / 0.0 / 0.01%/step]
1004 063	PFU: LS: SP	*EGB	Adjusts the speed of the feed motor in the optional paper tray unit. [-4.00 to 4.00 / -1.14 / 0.01%/step]
1004 064	Duplex: LS: SP	*EGB	Adjusts the duplex motor speed. [-4.00 to 4.00 / -0.36 / 0.01%/step]
1004 065	DEV / OPC [K]: LS: TN	*EGB	Adjusts the black development and OPC motor speed. [-4.00 to 4.00 / -1.35 / 0.01 %/step]
1004 066	DEV / OPC [K]: RS: TN	*EGB	
1004 067	DEV [CMY]: LS: Thin	*EGB	Adjusts the color development motor speed. [-4.00 to 4.00 / 0.0 / 0.01%/step]
1004 068	DEV [CMY]: RS: Thin	*EGB	
1004 069	OPC [CMY]: LS: Thin	*EGB	Adjusts the color OPC motor speed. [-4.00 to 4.00 / -1.35 / 0.01%/step]
1004 070	OPC [CMY]: RS: Thin	*EGB	
1004 071	Fusing: LS: Thin	*EGB	Adjusts the paper exit and fusing motor speed. [-4.00 to 4.00 / 1.4 / 0.01%/step]
1004 072	Fusing: RS: Thin	*EGB	
1004 073	Trans. Belt: LS: TN	*EGB	Adjusts the transfer belt motor speed. [-4.00 to 4.00 / 0.0 / 0.01%/step]
1004 074	Trans. Belt: RS: TN	*EGB	
1004 075	PFU: LS: Thin	*EGB	Adjusts the speed of the feed motor in the optional paper tray unit. [-4.00 to 4.00 / -0.36 / 0.01%/step]
1004 076	PFU: RS: Thin	*EGB	
1004 077	Duplex: LS: Thin	*EGB	Adjusts the duplex motor speed. [-4.00 to 4.00 / -0.36 / 0.01%/step]
1004 078	Duplex: RS: Thin	*EGB	

1004 079	DEV / OPC [K]: LS: OHP	*EGB	Adjusts the black development and OPC motor speed. [-4.00 to 4.00 / -1.35 / 0.01 %/step]
1004 080	DEV [CMY]: LS: OHP	*EGB	Adjusts the color development motor speed. [-4.00 to 4.00 / 0.0 / 0.01%/step]
1004 081	OPC [CMY]: LS: OHP	*EGB	Adjusts the color OPC motor speed. [-4.00 to 4.00 / -1.35 / 0.01%/step]
1004 082	Fusing: LS: OHP	*EGB	Adjusts the paper exit and fusing motor speed. [-4.00 to 4.00 / 0.6 / 0.01%/step]
1004 083	T.Belt: LS: OHP	*EGB	Adjusts the transfer belt motor speed. [-4.00 to 4.00 / 0.0 / 0.01%/step]
1004 084	PFU: LS: OHP	*EGB	Adjusts the speed of the feed motor in the optional paper tray unit. [-4.00 to 4.00 / -1.14 / 0.01%/step]
1004 085	Duplex: LS: OHP	*EGB	Adjusts the duplex motor speed. [-4.00 to 4.00 / -0.36 / 0.01%/step]

1006	[Phase Adjust.] Phase Adjustment		
1006 001	Angle	*EGB	Adjusts the phase angle between the K drum and the CMY drums. [-180 to 180 / 0 / 1°/step] DFU

1104	[Fusing Cont.] Fusing Control		
1104 001	Control Method	*EGB	[0 or 1 / 1 / -] Alphanumeric
	Selects the fusing control method. 0: ON/OFF Control 1: PID Control (Phase control)		
1104 022	Max. Wait Time	*EGB	[0 to 255 / 30 / 1 sec/step]
	Adjusts the maximum waiting time for the target printing temperature of fusing unit. After this interval, printing will start if the temperature did not get to the target.		
1104 023	Paper Feed. Temp.	*EGB	[0 to 30 / 5 / 1°/step]
	Adjusts the increase in the temperature of the fusing unit between the ready condition and the start of paper feed at the start of a new job.		
1104 024	1st Add Time: LS		[0 to 50 / 0 / 0.1 sec/step]
	For print jobs at low speed. If the interval between jobs is less than this setting, then the temperature change (1104 025) for the first page of a new job is not applied.		
1104 025	1st Add Temp.	*EGB	[0 to 20 / 0 / 1°C/step]
	Adds this value to the basic fusing temperature, for the first page of a new job. This extra temperature is necessary because when the printer starts the first page, the fusing unit is not warm enough.		
1104 026	1st Temp. Maint.	*EGB	[0 to 50 / 0 / 1 sec/step]
	Adjusts the time for maintaining the temperature change that is set with 1104 025.		
1104 027	1st Print Inter.	*EGB	[0 to 100 / 0.2 / 0.1 sec/step]
	For print jobs at regular speed. If the interval between jobs is less than this setting, then the temperature change (1104 025) for the first page of a new job is not applied.		

1105	[Fusing Temp.] Fusing Temperature (Paper Type, Mode, Color, Process Speed) Paper Type -> N: Plain paper 1, N2: Plain paper 2, TC: Thick, TN: Thin, SP: Special, OHP Mode -> Simple [one-sided] or Duplex Color -> K: Black only, FC: Full color Process Speed -> LS: Low speed, RS: Regular speed Reload: Print ready, between jobs		
	Adjusts the fusing unit temperature for each mode.		
1105 022	Reload Temp.	*EGB	[100 to 200 / 160 / 1°C/step]
1105 025	TC1: Simple: [K]	*EGB	[120 to 180 / 160 / 1°C/step]
1105 026	TC1: Duplex: [K]	*EGB	
1105 027	TC1: Simple: [FC]	*EGB	
1105 028	TC1: Duplex: [FC]	*EGB	
1105 029	TC2: Simple: [K]	*EGB	
1105 031	TC2: Simple: [FC]	*EGB	
1105 033	N: Simple: [K]: LS	*EGB	[120 to 180 / 145 / 1°C/step]
1105 034	N: Simple: [K]: RS	*EGB	[120 to 180 / 160 / 1°C/step]
1105 035	N: Duplex: [K]: LS	*EGB	[120 to 180 / 145 / 1°C/step]
1105 036	N: Duplex: [K]: RS	*EGB	[120 to 180 / 160 / 1°C/step]
1105 037	N: Simple: [FC]: LS	*EGB	[120 to 180 / 145 / 1°C/step]
1105 039	N: Simple: [FC]: RS	*EGB	[120 to 180 / 160 / 1°C/step]
1105 040	N: Duplex: [FC]: LS	*EGB	[120 to 180 / 145 / 1°C/step]
1105 042	N: Duplex: [FC]: RS	*EGB	[120 to 180 / 160 / 1°C/step]
1105 043	Check Temp. Time	*EGB	[0 to 10 / 2.0 / 0.1 sec/step]
	Adjusts the rotation time before checking the fusing unit temperature. If the main switch is turned on and off for a short time, it might be possible that the checked temperature is high even though the whole of the fusing unit is not high enough for printing condition.		
1105 049	N2: Simple: [K]: LS	*EGB	[120 to 180 / 150 / 1°C/step]
1105 050	N2: Simple: [K]: RS	*EGB	[120 to 180 / 165 / 1°C/step]
1105 051	N2: Duplex: [K]: LS	*EGB	[120 to 180 / 150 / 1°C/step]
1105 052	N2: Duplex: [K]: RS	*EGB	[120 to 180 / 165 / 1°C/step]
1105 053	N2: Simple: [FC] LS	*EGB	[120 to 180 / 150 / 1°C/step]
1105 054	N2: Simple: [FC] RS	*EGB	[120 to 180 / 165 / 1°C/step]
1105 055	N2: Duplex: [FC] LS	*EGB	[120 to 180 / 150 / 1°C/step]
1105 056	N2: Duplex: [FC] RS	*EGB	[120 to 180 / 165 / 1°C/step]
1105 057	TN: Simple: [K]: LS	*EGB	[120 to 180 / 135 / 1°C/step]
1105 058	TN: Simple: [K]: RS	*EGB	[120 to 180 / 150 / 1°C/step]
1105 059	TN: Duplex: [K]: LS	*EGB	[120 to 180 / 135 / 1°C/step]
1105 060	TN: Duplex: [K] RS	*EGB	[120 to 180 / 150 / 1°C/step]
1105 061	TN: Simple: [FC] LS	*EGB	[120 to 180 / 135 / 1°C/step]
1105 062	TN: Simple: [FC] RS	*EGB	[120 to 180 / 150 / 1°C/step]
1105 063	TN: Duplex: [FC] LS	*EGB	[120 to 180 / 135 / 1°C/step]
1105 064	TN: Duplex: [FC] RS	*EGB	[120 to 180 / 150 / 1°C/step]
1105 065	SP1: Simple: [K] LS	*EGB	[120 to 180 / 165 / 1°C/step]
1105 067	SP1: Duplex: [K] LS	*EGB	[120 to 180 / 165 / 1°C/step]

1105 069	SP1: Simp.: [FC] LS	*EGB	[120 to 180 / 165 / 1°C/step]
1105 071	SP1: Dupl.: [FC] LS	*EGB	[120 to 180 / 165 / 1°C/step]
1105 089	OHP: [K]: LS	*EGB	[120 to 180 / 160 / 1°C/step]
1105 090	OHP: [FC]: LS	*EGB	[120 to 180 / 160 / 1°C/step]

1106	[Fusing Temp.] Fusing Temperature H. Roller: Heat Roller		
1106 002	H. Roller Temp.		Displays the heating roller temperature at this time. [0 to 230 / 0 / 1°C/step]

1911	[Print Speed Ctl] Print Speed Control for small paper sizes (A5 or smaller) (Sheets of paper, Interval time or Temperature, Process Speed) Simple [one-sided] or Duplex Process Speed -> LS: Low speed, RS: Regular speed See section 6 for more about these SPs.		
1911 001	PPM Down: RS: S	*EGB	The print speed (PPM) is reduced after the machine has printed this number of pages continuously. [0 to 99 / 15 / 1 sheet/step]
1911 002	PPM Down: LS: S	*EGB	
1911 003	PPM Down Inter.	*EGB	The print speed goes back to the normal speed after this interval. [0 to 255 / 30 / 1 sec/step]
1911 004	S-size Temp. 1	*EGB	The temperature is decreased by this amount to prevent overheating the fusing unit for small size paper. [0 to 200 / 2 / 1°C/step]
1911 006	S-size Temp. 2	*EGB	These SPs control when the above temperature reductions are done. [0 to 255 / 30 / 1 sheet/step]
1911 008	S-size Temp. 3	*EGB	
1911 014	S-size Temp.: S1	*EGB	
1911 016	S-size Temp.: S2	*EGB	[0 to 255 / 20 / 1 sheet/step]
1911 018	S-size Temp.: S3	*EGB	[0 to 255 / 50 / 1 sheet/step]
1911 021	Simple Temp. 1	*EGB	Adjusts the temperature reduction for one-sided printing. [0 to 200 / 2 / 1°C/step]
1911 022	Simple Temp. 2	*EGB	[0 to 200 / 5 / 1°C/step]
1911 023	Simple Temp.:S1	*EGB	These SPs control when the above temperature reductions are done. [0 to 500 / 100 / 1 sheet/step]
1911 024	Simple Temp.:S2	*EGB	[0 to 500 / 30 / 1 sheet/step]
1911 025	Duplex Temp. 1	*EGB	Adjusts the temperature reduction for duplex printing. [0 to 200 / 2 / 1°C/step]
1911 026	Duplex Temp. 2	*EGB	[0 to 200 / 5 / 1°C/step]
1911 027	Duplex Temp.: S1	*EGB	These SPs control when the above temperature reductions are done. [0 to 500 / 80 / 1 sheet/step]

1911 028	Duplex Temp.: S2	*EGB	[0 to 500 / 20 / 1 sheet/step]
----------	------------------	------	---------------------------------------

1912	[Fusing Rotat.] Fusing Unit Roller Rotation Control Paper Type -> TC1: Thick paper 1, TC2: Thick paper 2, OHP, SP: Special		
1912 001	Rotation	*EGB	[0 or 1 / 1 / -] 0: Off 1: On.
	When the printer is in the ready condition, the nip between the hot roller and pressure roller is in the same position. This may cause deformation of the rollers. Therefore, a temporary rotation prevents this problem. SP 1912 001 turns this feature on or off. SP1912-003 and 004 control this rotation. Pre-rotation: Fusing idling		
1912 002	Prerotat. Speed	*EGB	[0 to 2 / 2 / -]
	Adjusts the speed of the fusing-unit rollers during fusing idling. 0: 1/3 regular speed, 1: Low speed, 2: Regular speed		
1912 003	Rotation Freque.	*EGB	[1 to 24 / 4 / 1 hour/step]
	Adjusts the frequency of the fusing-unit roller rotation if the machine is in the ready condition for a very long interval.		
1912 004	Rotation Inter.	*EGB	[0 to 25 / 0.1 / 0.1 sec/step]
	Adjusts the duration of the fusing-unit roller rotation		
1912 005	Prerotat. Temp.	*EGB	[0 to 200 / 100 / 1°C/step]
	Fusing idling is not done if the fusing unit temperature is above this value.		
1912 006	Prerotat. Inter.	*EGB	[0 to 180 / 1 / 1 min/step]
	Adjusts the duration of fusing idling immediately after the power is turned on.		
1912 007	Ex. Rotation Time	*EGB	[0 to 10 / 5 / 1 sec/step]
	Adjusts the time for extra rotation of the fusing unit rollers at the end of a job. If the fusing motor stops before the fusing lamp turns off, the temperature can become very high.		
1912 008	Prerotat. Ext.	*EGB	[0 to 255 / 0 / 1 sec/step]
	Adjusts the additional time for pre-rotation of the fusing rollers.		
1912 010	TC1: Rotat. Ext.	*EGB	[0 to 255 / 10 / 1 sec/step]
	Adjusts the additional time of the fusing roller pre-rotation for thick paper 1.		
1912 011	TC2 Rotat. Ext.	*EGB	[0 to 255 / 15 / 1 sec/step]
	Adjusts the additional time of the fusing roller pre-rotation for thick paper 2.		
1912 012	OHP: Rotat. Ext.	*EGB	[0 to 255 / 15 / 1 sec/step]
	Adjusts the additional time of the fusing roller pre-rotation for OHP.		
1912 013	SP: Rotat. Ext.	*EGB	[0 to 255 / 15 / 1 sec/step]
	Adjusts the additional time of the fusing roller pre-rotation for special paper.		

1913	[Heating Roller] Heating Roller Control		
1913 002	Stand-by Temp.	*EGB	[0 to 200 / 150 / 1°C/step]
	Adjusts the heating roller temperature when the machine is in the ready condition.		

1916	[Nip Measure] Fusing Nip Width Measurement		DFU
1916 001	Nip Measure Exe.		[0 or 1 / 0 /-] 0: Not execute, 1: Execute Performs the nip width measurement.
1916 002	Prerotation Time	*EGB	[0 to 60 / 10 / 1 sec/step] Adjusts the rotation time of the fusing unit rollers before the nip measurement.

1917	[Environ. Adapt.] Fusing Idling: Environment Correction The machine automatically adjusts the duration of fusing idling, depending on room temperature measured by the temperature/humidity sensor (Paper Type, Temperature Environment, Value of Temperature/ Rotation Time) Paper Type ->N1: Plain paper 1, N2: Plain paper 2, T1: Thick paper 1, T2: Thick paper 2, SP: Special (see the Specifications table for details on these paper weights) Temperature Environment -> H: High temperature, L: Low temperature Value of Temperature/ Time: Dec.: Decrease, Inc.: Increase		
1917 003	H: Rotat. Time Dec.	*EGB	Adjusts the rotation time decrease at high temperature. [-120 to 0 / 0 / 1 sec/step]
1917 004	N1: H: Temp. Dec.	*EGB	Adjusts the temperature decrease for plain paper 1 at high temperature. [-50 to 0 / 0 / 1°C/step]
1917 005	N1: L: Temp. Inc.	*EGB	Adjusts the temperature increase for plain paper 1 at low temperature. [0 to 30 / 7 / 1°C/step]
1917 006	L: Rotat. Time Inc.	*EGB	Adjusts the rotation time increase at low temperature. [0 to 120 / 0 / 1 sec/step]
1917 007	H: Standard Temp.	*EGB	Sets the threshold temperature detected as high temperature. [25 to 40 / 30 / 1°C/step]
1917 008	L: Standard Temp.	*EGB	Sets the threshold temperature detected as low temperature. [-15 to 30 / 18 / 1°C/step]
1917 009	L: Rotation Dec.	*EGB	Adjusts the rotation time decrease at low temperature. [0 to 100 / 20 / 1 sec/step]
1917 010	N2: H: Temp. Dec.	*EGB	Adjusts the temperature decrease for plain paper 2 at high temperature. [-50 to 0 / 0 / 1 sec/step]
1917 011	N2: L: Temp. Inc.	*EGB	Adjusts the temperature increase for plain paper 2 at low temperature. [0 to 30 / 10 / 1°C/step]
1917 012	TN: H: Temp. Dec.	*EGB	Adjusts the temperature decrease for thin paper at high temperature. [-50 to 0 / 0 / 1 sec/step]
1917 013	TN: L: Temp. Inc.	*EGB	Adjusts the temperature increase for thin paper at low temperature. [0 to 30 / 7 / 1°C/step]

1917 014	TC1: H: Temp. Dec.	*EGB	Adjusts the temperature decrease for thick paper 1 at high temperature. [-50 to 0 / 0 / 1 sec/step]
1917 015	TC1: L: Temp. Inc.	*EGB	Adjusts the temperature increase for thick paper 1 at low temperature. [0 to 30 / 7 / 1°C/step]
1917 016	TC2: H: Temp. Dec.	*EGB	Adjusts the temperature decrease for thick paper 2 at high temperature. [-50 to 0 / 0 / 1 sec/step]
1917 017	TC2: L: Temp. Inc.	*EGB	Adjusts the temperature increase for thick paper 2 at low temperature. [0 to 30 / 7 / 1°C/step]
1917 018	OHP: H: Temp. Dec.	*EGB	Adjusts the temperature decrease for OHP at high temperature. [-50 to 0 / 0 / 1 sec/step]
1917 019	OHP: L: Temp. Inc.	*EGB	Adjusts the temperature increase for OHP at low temperature. [0 to 30 / 7 / 1°C/step]
1917 020	SP: H: Temp. Dec.	*EGB	Adjusts the temperature decrease for special paper at high temperature. [-50 to 0 / 0 / 1 sec/step]
1917 021	SP: L: Temp. Inc.	*EGB	Adjusts the temperature increase for special paper at low temperature. [0 to 30 / 7 / 1°C/step]

SP2-XXX (Drum)

2101	[Color Regist.] Color Registration Correction ([Color], M: Main scan, S: Sub scan)		
	You can adjust these SPs if the color registration is not good after the Line Position Adjustment (also known as 'MUSIC') is done. The [K] value (-001) is the standard value in the main scan adjustment. The values other than [k] value are added to [K] value. So, [K] value normally does not need to be adjusted in the main scan adjustment.		
2101 001	[K]: M Regist. Dot	*EGB	Adjusts the side edge registration by a dot for each mode. [-128 to 127 / 0 / 1 dot/step]
2101 002	[M]: M Regist. Dot	*EGB	
2101 003	[C]: M Regist. Dot	*EGB	
2101 004	[Y]: M Regist. Dot	*EGB	
2101 005	[K]: M Reg. SubD	*EGB	Adjusts the side edge registration by 1/16 dot. [-15 to 15 / 0 / 1/16dot/step]
2101 006	[K-M]: M Reg. SubD	*EGB	
2101 007	[K-C]: M Reg. SubD	*EGB	
2101 008	[K-Y]: M Reg. SubD	*EGB	
2101 013	[K-M]: S Reg. 600	*EGB	[-128 to 127 / 0 / 1 line/step]
2101 014	[K-C]: S Reg. 600	*EGB	
2101 015	[K-Y]: S Reg. 600	*EGB	
2101 016	[K-M]: S Reg. 1200	*EGB	
2101 017	[K-C]: S Reg. 1200	*EGB	
2101 018	[K-Y]: S Reg. 1200	*EGB	

2103	[Trim Adjust.] Erase Margin Adjustment Lead Ed: Leading Edge, Trail. Ed: Trailing Edge, Left/Right Ed: Left/ Right Edge		
2103 001	Lead Ed. Width	*EGB	Adds this value to the leading edge erase margin position in the sub scan direction. [-127 to 127 / 71 / 1 line/step]
2103 002	Trail. Ed. Width	*EGB	Adds this value to the trailing edge erase margin position in the sub scan direction. [-127 to 127 / 71 / 1 line/step]
2103 003	Left Ed. Width	*EGB	Adds this value to the left edge erase margin position in the main scan direction. [-127 to 127 / 47 / 1 dot/step]
2103 004	Right Ed. Width	*EGB	Adds this value to the right edge erase margin position in the main scan direction. [-127 to 127 / 47 / 1 dot/step]

2104	[Magnifi. Adj.] Magnification Adjustment ([Color], Main Scan Magnification)		
2104 001	[K]: M Magnifi.	*EGB	Adjusts the main scan magnification. [-1.00 to 1.00 / 0.00 / 0.01%/step]
2104 002	[M]: M Magnifi.	*EGB	
2104 003	[C]: M Magnifi.	*EGB	
2104 004	[Y]: M Magnifi.	*EGB	

2105	[LD Power Cont.] LD Power Control ([Color], Process Speed) Process Speed -> LS: Low speed, RS: Regular speed		
2105 001	[K] 0	*EGB	Adjusts the LD power. [10 to 200 / 100 / 1%/step] DFU
2105 002	[M] 0	*EGB	
2105 003	[C] 0	*EGB	
2105 004	[Y] 0	*EGB	
2105 009	[K] 0: LS	*EGB	Adjusts the LD power at low speed. [10 to 200 / 100 / 1%/step] DFU
2105 010	[M] 0: LS	*EGB	
2105 011	[C] 0: LS	*EGB	
2105 012	[Y] 0: LS	*EGB	

2109	[LD BeamPattern] LD Beam Pattern		
2109 001	Picture Addition		Adds the picture to the LD beam pattern. [0 or 1 / 0 / -] 0: Not execute, 1: Execute
2109 002	Pattern Select		Selects the LD beam pattern. [0 to 24 / 0 / 1/step]
2109 004	Color Select		Selects the color for the LD beam pattern. [0 to 4 / 0 / 1/step]

2111	[Manual Execut.] Manual Execution		
2111 001	Position Adjust.		Performs the line position adjustment.
2111 002	Pro. Position Adj.		Performs an approximate line position adjustment.
2111 003	Skew Adjust.		Performs the skew adjustment.
2111 004	ID S. Adjust.		Tests the ID sensor.

2120	[LD Off Check]		
			Displays the LD off check state.

2143	[ID S. Display] ID Sensor Display The ID sensor assembly has three sensors: Left, Center, Right		
2143 001	PWM: Left	*EGB	Displays the PWM value for each sensor. [0 to 512 / 0 / 1/step]
2143 002	PWM: Center	*EGB	
2143 003	PWM: Right	*EGB	
2143 004	Avg: Left	*EGB	Displays the average output from each sensor. [0.00 to 5.00 / 0.00 / 0.01 volt/step]
2143 005	Avg: Center	*EGB	
2143 006	Avg: Right	*EGB	
2143 007	Max: Left	*EGB	Displays the maximum output from each sensor. [0.00 to 5.00 / 0.00 / 0.01 volt/step]
2143 008	Max: Center	*EGB	
2143 009	Max: Right	*EGB	
2143 010	Min: Left	*EGB	Displays the minimum output from each sensor. [0.00 to 5.00 / 0.00 / 0.01 volt/step]
2143 011	Min: Center	*EGB	
2143 012	Min: Right	*EGB	
2143 013	Max2: Left	*EGB	Displays the maximum 2 output from each sensor.
2143 014	Max2: Center	*EGB	

2143 015	Max2: Right	*EGB	[0.00 to 5.00 / 0.00 / 0.01 volt/step]
2143 016	Min2: Left	*EGB	Displays the maximum 2 output from each sensor.
2143 017	Min2: Center	*EGB	
2143 018	Min2: Right	*EGB	[0.00 to 5.00 / 0.00 / 0.01 volt/step]

2150	[Area Magni. Cor] Area Magnification Correction ([Color], Area)		
2150 001	[K]: Area 1	*EGB	Adjusts the magnification correction for each area. [-127 to 127 / 0 / 1 sub-dot/step]
2150 002	[K]: Area 2	*EGB	
2150 003	[K]: Area 3	*EGB	
2150 004	[K]: Area 4	*EGB	
2150 005	[K]: Area 5	*EGB	
2150 006	[K]: Area 6	*EGB	
2150 007	[K]: Area 7	*EGB	
2150 008	[K]: Area 8	*EGB	
2150 009	[K]: Area 9	*EGB	
2150 010	[K]: Area 10	*EGB	
2150 011	[K]: Area 11	*EGB	
2150 012	[K]: Area 12	*EGB	
2150 013	[M]: Area 1	*EGB	Adjusts the magnification correction for each area. [-127 to 127 / 0 / 1 sub-dot/step]
2150 014	[M]: Area 2	*EGB	
2150 015	[M]: Area 3	*EGB	
2150 016	[M]: Area 4	*EGB	
2150 017	[M]: Area 5	*EGB	
2150 018	[M]: Area 6	*EGB	
2150 019	[M]: Area 7	*EGB	
2150 020	[M]: Area 8	*EGB	
2150 021	[M]: Area 9	*EGB	
2150 022	[M]: Area 10	*EGB	
2150 023	[M]: Area 11	*EGB	
2150 024	[M]: Area 12	*EGB	
2150 025	[C]: Area 1	*EGB	Adjusts the magnification correction for each area. [-127 to 127 / 0 / 1 sub-dot/step]
2150 026	[C]: Area 2	*EGB	
2150 027	[C]: Area 3	*EGB	
2150 028	[C]: Area 4	*EGB	
2150 029	[C]: Area 5	*EGB	
2150 030	[C]: Area 6	*EGB	
2150 031	[C]: Area 7	*EGB	
2150 032	[C]: Area 8	*EGB	
2150 033	[C]: Area 9	*EGB	
2150 034	[C]: Area 10	*EGB	
2150 035	[C]: Area 11	*EGB	
2150 036	[C]: Area 12	*EGB	
2150 037	[Y]: Area 1	*EGB	Adjusts the magnification correction for each area. [-127 to 127 / 0 / 1 sub-dot/step]
2150 038	[Y]: Area 2	*EGB	
2150 039	[Y]: Area 3	*EGB	
2150 040	[Y]: Area 4	*EGB	
2150 041	[Y]: Area 5	*EGB	

2150 042	[Y]: Area 6	*EGB	
2150 043	[Y]: Area 7	*EGB	
2150 044	[Y]: Area 8	*EGB	
2150 045	[Y]: Area 9	*EGB	
2150 046	[Y]: Area 10	*EGB	
2150 047	[Y]: Area 11	*EGB	
2150 048	[Y]: Area 12	*EGB	

2151	[Area Width] Area Width Correction ([Color], Area)		
2151 001	[K]: Area 1	*EGB	[0 to 1024 / 355 / 1 dot/step]
2151 002	[K]: Area 2	*EGB	
2151 003	[K]: Area 3	*EGB	[0 to 1024 / 472 / 1 dot/step]
2151 004	[K]: Area 4	*EGB	
2151 005	[K]: Area 5	*EGB	
2151 006	[K]: Area 6	*EGB	
2151 007	[K]: Area 7	*EGB	
2151 008	[K]: Area 8	*EGB	
2151 009	[K]: Area 9	*EGB	
2151 010	[K]: Area 10	*EGB	
2151 011	[K]: Area 11	*EGB	[0 to 1024 / 355 / 1 dot/step]
2151 012	[K]: Area 12	*EGB	
2151 013	[M]: Area 1	*EGB	[0 to 1024 / 355 / 1 dot/step]
2151 014	[M]: Area 2	*EGB	
2151 015	[M]: Area 3	*EGB	[0 to 1024 / 472 / 1 dot/step]
2151 016	[M]: Area 4	*EGB	
2151 017	[M]: Area 5	*EGB	
2151 018	[M]: Area 6	*EGB	
2151 019	[M]: Area 7	*EGB	
2151 020	[M]: Area 8	*EGB	
2151 021	[M]: Area 9	*EGB	
2151 022	[M]: Area 10	*EGB	
2151 023	[M]: Area 11	*EGB	[0 to 1024 / 355 / 1 dot/step]
2151 024	[M]: Area 12	*EGB	
2151 025	[C]: Area 1	*EGB	[0 to 1024 / 355 / 1 dot/step]
2151 026	[C]: Area 2	*EGB	
2151 027	[C]: Area 3	*EGB	[0 to 1024 / 472 / 1 dot/step]
2151 028	[C]: Area 4	*EGB	
2151 029	[C]: Area 5	*EGB	
2151 030	[C]: Area 6	*EGB	
2151 031	[C]: Area 7	*EGB	
2151 032	[C]: Area 8	*EGB	
2151 033	[C]: Area 9	*EGB	
2151 034	[C]: Area 10	*EGB	
2151 035	[C]: Area 11	*EGB	[0 to 1024 / 355 / 1 dot/step]
2151 036	[C]: Area 12	*EGB	
2151 037	[Y]: Area 1	*EGB	[0 to 1024 / 355 / 1 dot/step]
2151 038	[Y]: Area 2	*EGB	

2151 039	[Y]: Area 3	*EGB	[0 to 1024 / 472 / 1 dot/step]
2151 040	[Y]: Area 4	*EGB	
2151 041	[Y]: Area 5	*EGB	
2151 042	[Y]: Area 6	*EGB	
2151 043	[Y]: Area 7	*EGB	
2151 044	[Y]: Area 8	*EGB	
2151 045	[Y]: Area 9	*EGB	
2151 046	[Y]: Area 10	*EGB	[0 to 1024 / 355 / 1 dot/step]
2151 047	[Y]: Area 11	*EGB	
2151 048	[Y]: Area 12	*EGB	

2152	[Area Shading] Area Shading Correction Setting ([Color], Area)		
2152 006	[K]: Area 0	*EGB	[0.10 to 2.00 / 1.00 / 0.01/step]
2152 007	[K]: Area 1	*EGB	
2152 008	[K]: Area 2	*EGB	
2152 009	[K]: Area 3	*EGB	
2152 010	[K]: Area 4	*EGB	
2152 011	[K]: Area 5	*EGB	
2152 012	[K]: Area 6	*EGB	
2152 013	[K]: Area 7	*EGB	
2152 014	[K]: Area 8	*EGB	
2152 015	[K]: Area 9	*EGB	
2152 016	[K]: Area 10	*EGB	[0.10 to 2.00 / 1.00 / 0.01/step]
2152 017	[M]: Area 0	*EGB	
2152 018	[M]: Area 1	*EGB	
2152 019	[M]: Area 2	*EGB	
2152 020	[M]: Area 3	*EGB	
2152 021	[M]: Area 4	*EGB	
2152 022	[M]: Area 5	*EGB	
2152 023	[M]: Area 6	*EGB	
2152 024	[M]: Area 7	*EGB	
2152 025	[M]: Area 8	*EGB	
2152 026	[M]: Area 9	*EGB	
2152 027	[M]: Area 10	*EGB	[0.10 to 2.00 / 1.00 / 0.01/step]
2152 028	[C]: Area 0	*EGB	
2152 029	[C]: Area 1	*EGB	
2152 030	[C]: Area 2	*EGB	
2152 031	[C]: Area 3	*EGB	
2152 032	[C]: Area 4	*EGB	
2152 033	[C]: Area 5	*EGB	
2152 034	[C]: Area 6	*EGB	
2152 035	[C]: Area 7	*EGB	
2152 036	[C]: Area 8	*EGB	
2152 037	[C]: Area 9	*EGB	[0.10 to 2.00 / 1.00 / 0.01/step]
2152 038	[C]: Area 10	*EGB	
2152 039	[Y]: Area 0	*EGB	
2152 040	[Y]: Area 1	*EGB	

Service Tables

2152 041	[Y]: Area 2	*EGB	
2152 042	[Y]: Area 3	*EGB	
2152 043	[Y]: Area 4	*EGB	
2152 044	[Y]: Area 5	*EGB	
2152 045	[Y]: Area 6	*EGB	
2152 046	[Y]: Area 7	*EGB	
2152 047	[Y]: Area 8	*EGB	
2152 048	[Y]: Area 9	*EGB	
2152 049	[Y]: Area 10	*EGB	

2153	[MUSIC Setting] Timing for Automatic Line Position Adjustment (MUSIC)		
2153 001	Auto Execution	*EGB	Enables or disables the automatic line position adjustment. If this SP is 0, the adjustment is never done. [0 or 1 / 1 / -] Alphanumeric 0: Off, 1: On
2153 002	Process Control	*EGB	Enables or disables the adjustment after process control is done. [0 or 1 / 1 / -] Alphanumeric 0: Off, 1: On
2153 003	Initialization	*EGB	Enables or disables the adjustment immediately after the power is turned on or when recovering from energy save mode. [0 or 1 / 1 / -] Alphanumeric 0: Off, 1: On
2153 004	Data In	*EGB	Enables or disables the adjustment immediately after the machine starts to receive print job data. The adjustment is done if one of the conditions set with SP2153-012, -013 and -015 is satisfied. [0 or 1 / 1 / -] Alphanumeric 0: Off, 1: On
2153 005	Cut In	*EGB	Enables or disables the adjustment during printing. The adjustment is done if one of the conditions set with SP2153-012, -013 and -015 is satisfied. [0 or 1 / 1 / -] Alphanumeric 0: No, 1: Yes
2153 006	Job End	*EGB	Enables or disables the adjustment after printing. [0 or 1 / 0 / -] Alphanumeric 0: Off, 1: On
2153 008	Trans. Belt Speed 2	*EGB	Enables or disables the transfer belt speed correction during the adjustment. The transfer belt speed is affected by changes in temperature. A change of the transfer belt speed during the adjustment causes color registration errors. This SP keeps the transfer belt at a constant speed. [0 or 1 / 1 / -] Alphanumeric 0: Off, 1: On

2153 010	Manual Cut In	*EGB	If this number of pages was printed after the previous adjustment was done, then the adjustment is done again. The number of sheets is counted in SP7806-003 and -004. [10 to 999 / 190 / 1 page/step]
2153 012	MUSIC Temp.	*EGB	If the room temperature changes by this amount or more after the previous adjustment was done, then the adjustment is done again. [2 to 30 / 5 / 1°C/step]
2153 013	Passage Time	*EGB	If this amount of time has passed after the previous adjustment was done, then the adjustment is done again. [0 to 1440 / 360 / 1 min/step]
2153 015	Maginificat. Error	*EGB	Sets the threshold (magnification error) from previous MUSIC for executing MUSIC. [0 to 10 / 1 / 0.1%/step]

2181	[MUSIC Result] Result of Automatic Line Position Adjustment ([Color], Value, Unit) Value-> Skew, Bent, M. Scan Erro.: Main Scan Error, S. Scan Erro.: Sub Scan Error, M. Cor: Main Scan Correction, S. Cor: Sub Scan Correction Unit-> Dot, SubD.: Sub Dot, 600/ 1200 dpi		
	The following SPs display the result of MUSIC for each mode.		
2181 001	[K]: Skew	*EGB	[-5000 to 5000 / 0 / 1 µm/step]
2181 002	[K]: Bent	*EGB	
2181 003	[K]: M. Scan Erro.	*EGB	
2181 004	[K]: S. Scan Erro.	*EGB	
2181 005	[K]: M Cor.: Dot	*EGB	[-127 to 127 / 0 / 1 dot/step]
2181 006	[K]: M Cor.: SubD.	*EGB	[-127 to 127 / 0 / 1 sub-dot/step]
2181 007	[K]: S Cor.: 600	*EGB	[-127 to 127 / 0 / 1 line/step]
2181 008	[K]: S Cor.: 1200	*EGB	[-127 to 127 / 0 / 1/step]
2181 011	[M]: Skew	*EGB	[-5000 to 5000 / 0 / 1 µm/step]
2181 012	[M]: Bent	*EGB	
2181 013	[M]: M. Scan Erro.	*EGB	
2181 014	[M]: S. Scan Erro.	*EGB	
2181 015	[M]: M Cor.: Dot	*EGB	[-127 to 127 / 0 / 1 dot/step]
2181 016	[M]: M Cor.: SubD..	*EGB	[-15 to 15 / 0 / 1 sub-dot/step]
2181 017	[M]: S Cor.: 600	*EGB	[-127 to 127 / 0 / 1 line/step]
2181 018	[M]: S Cor.: 1200	*EGB	[-127 to 127 / 0 / 1/step]
2181 021	[C]: Skew	*EGB	[-5000 to 5000 / 0 / 1 µm/step]
2181 022	[C]: Bent	*EGB	
2181 023	[C]: M. Scan Erro.	*EGB	
2181 024	[C]: S. Scan Erro.	*EGB	
2181 025	[C]: M Cor.: Dot	*EGB	[-127 to 127 / 0 / 1 dot/step]
2181 026	[C]: M Cor.: SubD..	*EGB	[-15 to 15 / 0 / 1 sub-dot/step]
2181 027	[C]: S Cor.: 600	*EGB	[-127 to 127 / 0 / 1 line/step]
2181 028	[C]: S Cor.: 1200	*EGB	[-127 to 127 / 0 / 1/step]
2181 031	[Y]: Skew	*EGB	[-999 to 999 / 0 / 1 µm/step]
2181 032	[Y]: Bent	*EGB	

2181 033	[Y]: M. Scan Erro.	*EGB	
2181 034	[Y]: S. Scan Erro.	*EGB	
2181 035	[Y]: M Cor.: Dot	*EGB	[-127 to 127 / 0 / 1 dot/step]
2181 036	[Y]: M Cor.: SubD..	*EGB	[-15 to 15 / 0 / 1 sub-dot/step]
2181 037	[Y]: S Cor.: 600	*EGB	[-127 to 127 / 0 / 1 line/step]
2181 038	[Y]: S Cor.: 1200	*EGB	[-127 to 127 / 0 / 1/step]

2186	[MUSIC Record] Automatic Line Position Adjustment Record		
	The following SPs display the MUSIC record.		
2186 001	Year	*EGB	[0 to 99 / 0 / 1 y/step]
2186 002	Month	*EGB	[1 to 12 / 1 / 1 m/step]
2186 003	Date	*EGB	[1 to 31 / 1 / 1 d/step]
2186 004	Time	*EGB	[0 to 23 / 0 / 1 h/step]
2186 005	Minute	*EGB	[0 to 59 / 0 / 1 y/step]
2186 006	Temperature	*EGB	[0 to 100 / 0 / 1°C/step]
2186 007	Result	*EGB	[0 to 999999 / 0 / 1 /step]
2186 008	Execution	*EGB	[0 to 9999 / 0 / 1 /step]
2186 009	Failure	*EGB	[0 to 9999 / 0 / 1 /step]

2201	[Charge Bias: DC] Charge Roller Voltage: DC (Process Speed, [Color]) Process Speed -> LS: Low speed, RS: Regular speed		
	These SPs adjust the DC voltage of the drum charge roller. These are used only when SP3-501-001 is set to "1".		
2201 001	RS: [K]	*EGB	[200 to 999 / 585 / 1 V/step]
2201 002	RS: [M]	*EGB	
2201 003	RS: [C]	*EGB	
2201 004	RS: [Y]	*EGB	
2201 006	LS: [K]	*EGB	
2201 007	LS: [M]	*EGB	
2201 008	LS: [C]	*EGB	
2201 009	LS: [Y]	*EGB	

2202	[Charge Bias: AC] Charge Roller Voltage: AC (Process Speed, [Color]) Process Speed -> LS: Low speed, RS: Regular speed		
	These SPs adjust the AC voltage of the drum charge roller. These are used only when SP2-202-011 is set to "1".		
2202 001	RS: [K]	*EGB	[0 to 3000 / 2000 / 1 V/step]
2202 002	RS: [M]	*EGB	
2202 003	RS: [C]	*EGB	
2202 004	RS: [Y]	*EGB	
2202 006	LS: [K]	*EGB	
2202 007	LS: [M]	*EGB	
2202 008	LS: [C]	*EGB	
2202 009	LS: [Y]	*EGB	
2202 011	Output Control	*EGB	[0 or 1 / 0 / -] 0: Process Control, 1: Setting

2203	[Charge Bias: AC] Charge Roller Voltage: AC/I (Process Speed, [Color]) Process Speed -> LS: Low speed, RS: Regular speed		
	These SPs adjust the AC/I bias of the drum charge roller. These are used only when SP3-501-001 is set to "1".		
2203 001	RS: [K]	*EGB	[0 to 1.5 / 0.49 / 0.01 mA/step]
2203 002	RS: [M]	*EGB	[0 to 1.5 / 0.48 / 0.01 mA/step]
2203 003	RS: [C]	*EGB	[0 to 1.5 / 0.49 / 0.01 mA/step]
2203 004	RS: [Y]	*EGB	[0 to 1.5 / 0.48 / 0.01 mA/step]

2204	[Charge Bias] Charge Roller Voltage: Corrections for humidity (Environmental correction, [Color]) For more about the humidity conditions, see SP 2304.		
2204 001	Environ. : HH: [K]	*EGB	[0 to 255 / 109 / 1%/step]
2204 002	Environ. : HH: [M]	*EGB	[0 to 255 / 107 / 1%/step]
2204 003	Environ. : HH: [C]	*EGB	[0 to 255 / 104 / 1%/step]
2204 004	Environ. : HH: [Y]	*EGB	[0 to 255 / 106 / 1%/step]
2204 006	Environ. : H: [K]	*EGB	[0 to 255 / 106 / 1%/step]
2204 007	Environ. : H: [M]	*EGB	[0 to 255 / 106 / 1%/step]
2204 008	Environ. : H: [C]	*EGB	[0 to 255 / 106 / 1%/step]
2204 009	Environ. : H: [Y]	*EGB	[0 to 255 / 104 / 1%/step]
2204 011	Environ. : MM: [K]	*EGB	[0 to 255 / 101 / 1%/step]
2204 012	Environ. : MM: [M]	*EGB	
2204 013	Environ. : MM: [C]	*EGB	[0 to 255 / 100 / 1%/step]
2204 014	Environ. : MM: [Y]	*EGB	
2204 016	Environ. : L: [K]	*EGB	[0 to 255 / 105 / 1%/step]
2204 017	Environ. : L: [M]	*EGB	[0 to 255 / 104 / 1%/step]
2204 018	Environ. : L: [C]	*EGB	[0 to 255 / 103 / 1%/step]
2204 019	Environ. : L: [Y]	*EGB	[0 to 255 / 105 / 1%/step]
2204 021	Environ. : LL: [K]	*EGB	[0 to 255 / 110 / 1%/step]
2204 022	Environ. : LL: [M]	*EGB	[0 to 255 / 109 / 1%/step]
2204 023	Environ. : LL: [C]	*EGB	[0 to 255 / 110 / 1%/step]
2204 024	Environ. : LL: [Y]	*EGB	[0 to 255 / 109 / 1%/step]

2212	[Dev. Bias: DC] Development Bias: DC (Process Speed, [Color]) Process Speed -> RS: Regular speed, LS: Low speed		
	These SPs adjust the development bias. These are used only when SP3-501-001 is set to "1".		
2212 001	RS: [K]	*EGB	[50 to 800 / 350 / 1 V/step]
2212 002	RS: [M]	*EGB	
2212 003	RS: [C]	*EGB	
2212 004	RS: [Y]	*EGB	
2212 005	LS: [K]	*EGB	
2212 006	LS: [M]	*EGB	
2212 007	LS: [C]	*EGB	
2212 008	LS: [Y]	*EGB	

2251	[Manual Toner] Forced Toner Supply Execution		
2251 001	[K]		Manually executes toner supply for each color. The toner supply procedure is done 10 times (supplied for one second on and one second off, repeated 10 times).
2251 002	[M]		
2251 003	[C]		
2251 004	[Y]		

2302	[Temp./Humidity] Temperature / Humidity Display		
2302 001	Temperature		Displays the temperature. [-128 to 127 / 0 / 0.1 deg/step]
2302 002	Relative Humidity		Display the relative humidity. [0 to 100 / 0 / 0.1%RH/step]
2302 003	Absolute Humidity		Display the absolute humidity. [0 to 100 / 0 / 0.1 g/m ³ /step]
2302 004	Current Environ.		Display the current environment. [0 to 4 / 0 / 1/step] 0: LL, 1: ML, 2: MM, 3: MH, 4: HH

2303	[Envir. Correct.] Environment Correction		
2303 001	Manual Correct.	*EGB	Manually sets the environment. [0 to 5 / 0 / 1/step] 0: OFF, 1: LL, 2: ML, 3: MM, 4: MH, 5: HH

2304	[EC Threshold] Environment Correction Threshold (Humidity, Environment) A. Humidity: Absolute Humidity		
	These SPs adjust the thresholds (absolute humidity) for each environment.		
2304 001	A. Humidity: LL-MM	*EGB	[0 to 100 / 5.0 / 0.1 g/m ³ /step]
2304 002	A. Humidity: ML-MM	*EGB	[0 to 100 / 8.0 / 0.1 g/m ³ /step]
2304 003	A. Humidity: MM-MH	*EGB	[0 to 100 / 16.0 / 0.1 g/m ³ /step]
2304 004	A. Humidity: MH-HH	*EGB	[0 to 100 / 26.0 / 0.1 g/m ³ /step]

2306	[Vd Link Corre.] Vd Link Correction		
2306 001	Setting	*EGB	Sets the Vd link correction. [0 or 1 / 0 / -] Alphanumeric 0: Execute, 1: Not execute
2306 002	Correction Coef.	*EGB	Adjusts the Vd link correction coefficient. [1.00 to 2.50 / 1.00 / 0.01/step]

2314	[Trans.Belt Bias] Transfer Belt Current at Process Control		
2314 011	Process Cont. [K]	*EGB	Adjusts the transfer belt current at process control for [K]. [0 to 60 / 15.0 / 0.1 μA/step]
2314 012	Process Cont. [M]	*EGB	Adjusts the transfer belt current at process control for [M, C, Y].
2314 013	Process Cont. [C]	*EGB	
2314 014	Process Cont. [Y]	*EGB	

2326	[T.Roll2 Clean.] Transfer Roller Cleaning (Positive or Negative Bias, Process Speed) Process Speed -> RS: Regular speed, LS: Low speed		
2326 002	Posi. Bias: RS	*EGB	Adjusts the positive voltage for transfer roller cleaning. [0 to 2 / 2.0 / 0.1 KV/step]
2326 003	Posi. Bias: LS	*EGB	
2326 005	Nega. Bias: RS	*EGB	Adjusts the negative voltage for transfer roller cleaning. [0 to 60 / 60.0 / 0.1V/step]
2326 006	Nega. Bias: LS	*EGB	

2352	[Trans.Belt Bias] Transfer Belt Current ([Color], Process Speed) Process Speed -> RS: Regular speed		
2352 001	[K]: RS		Adjusts the current that is applied to the transfer belt. [0 to 60 / 15.0 / 0.1 μ A/step]

2353	[Trans.Belt Bias] Transfer Belt Current ([Color], Process Speed) Process Speed -> LS: Low speed		
2353 001	[K]: LS	*EGB	Adjusts the current that is applied to the transfer belt. [0 to 60 / 6.0 / 0.1 μ A/step]

2357	[Trans.Belt Bias] Transfer Belt Current ([Color], Process Speed) Process Speed -> RS: Regular speed		
2357 001	[FC/ K]: RS	*EGB	Adjusts the current that is applied to the transfer belt. [0 to 60 / 15.0 / 0.1 μ A/step]
2357 002	[FC/ M]: RS	*EGB	
2357 003	[FC/ C]: RS	*EGB	
2357 004	[FC/ Y]: RS	*EGB	

2358	[Trans.Belt Bias] Transfer Belt Current ([Color], Process Speed) Process Speed -> LS: Low speed		
2358 001	[FC/ K]: LS	*EGB	Adjusts the current that is applied to the transfer belt. [0 to 60 / 6.0 / 0.1 μ A/step]
2358 002	[FC/ M]: LS	*EGB	
2358 003	[FC/ C]: LS	*EGB	
2358 004	[FC/ Y]: LS	*EGB	

2402	[Normal: [K]] Transfer roller current and discharge plate voltage for the image area, plain paper 1, black toner (Process Speed, Paper Side, Unit) Process Speed -> RS: Regular speed, Paper Side: 1st or 2nd Unit -> T.Roll2: Transfer roller, Separa.: Discharge plate (paper separation)		
2402 007	RS: 1st: T. Roll2	*EGB	Adjusts the transfer roller current. [0 to 60 / 25.0 / 0.1 μ A/step]
2402 008	RS: 1st: Separa.	*EGB	Adjusts the discharge plate voltage. [0 to 4 / 2.0 / 0.1 -KV/step]

2402 012	RS: 2nd: T. Roll2	*EGB	[0 to 60 / 12.5 / 0.1 - μ A/step]
2402 013	RS: 2nd: Separa.	*EGB	[0 to 4 / 2.0 / 0.1 -KV/step]

2403	[Normal: [K]] Transfer roller current and discharge plate voltage for the image area, plain paper 1, black toner (Process Speed, Paper Side) Process Speed -> LS: Low speed, Paper Side: 1st or 2nd		
2403 007	LS: 1st: T. Roll2	*EGB	Adjusts the transfer roller current. [0 to 60 / 15.0 / 0.1 - μ A/step]
2403 008	LS: 1st: Separa.	*EGB	Adjusts the discharge plate voltage. [0 to 4 / 2.0 / 0.1 -KV/step]
2403 012	LS: 2nd: T. Roll2	*EGB	[0 to 60 / 10.0 / 0.1 - μ A/step]
2403 013	LS: 2nd: Separa.	*EGB	[0 to 4 / 2.0 / 0.1 -KV/step]

2407	[Normal: [FC]] Transfer roller current and discharge plate voltage for the image area, plain paper 1, CMY toner (Process Speed, Paper Side) Process Speed -> RS: Regular speed, Paper Side: 1st or 2 nd		
2407 013	RS: 1st: T. Roll2	*EGB	Adjusts the transfer roller current. [0 to 60 / 20.0 / 0.1 - μ A/step]
2407 014	RS: 1st: Separa.	*EGB	Adjusts the discharge plate voltage. [0 to 4 / 2.0 / 0.1 -KV/step]
2407 021	RS: 2nd: T. Roll2	*EGB	[0 to 60 / 32.5 / 0.1 - μ A/step]
2407 022	RS: 2nd: Separa.	*EGB	[0 to 4 / 2.0 / 0.1 -KV/step]

2408	[Normal: [FC]] Transfer roller current and discharge plate voltage for the image area, plain paper 1, CMY toner (Process Speed, Paper Side) Process Speed -> LS: Low speed, Paper Side: 1st or 2nd		
2408 013	LS: 1st: T. Roll2	*EGB	Adjusts the transfer roller current. [0 to 60 / 17.5 / 0.1 - μ A/step]
2408 014	LS: 1st: Separa.	*EGB	Adjusts the discharge plate voltage. [0 to 4 / 2.0 / 0.1 -KV/step]
2408 021	LS: 2nd: T. Roll2	*EGB	[0 to 60 / 22.5 / 0.1 - μ A/step]
2408 022	LS: 2nd: Separa.	*EGB	[0 to 4 / 2.0 / 0.1 -KV/step]

2421	[Normal:[K]:LE] Transfer roller current and discharge plate voltage for the leading edge area, plain paper 1, black toner Paper Side: 1st or 2 nd Unit -> T.Roll2: Transfer roller, Separation: Discharge plate (paper separation)		
2421 003	Separation	*EGB	[0 to 400 / 100 / 5%/step]
2421 007	T.Roll2: 1st	*EGB	
2421 012	T.Roll2: 2nd	*EGB	

2422	[Switch Timing] Switch timing from leading edge to normal, plain paper 1 (Paper Type, Edge) Paper Type -> N: Normal LE: Leading Edge		
2422 002	T. Roll 2: N: LE	*EGB	[0 to 200 / 10 / 1 mm/step]
2422 003	Separation: N: LE	*EGB	[0 to 200 / 25 / 1 mm/step]

2423	[Normal: [K]: TE] Transfer roller current and discharge plate voltage for the trailing edge area, plain paper 1, black toner Paper side: 1st or 2nd Unit -> T.Roll2: Transfer roller, Separation: Discharge plate (paper separation)		
2423 003	Separation	*EGB	[0 to 400 / 100 / 5%/step]
2423 007	T. Roll 2: 1st	*EGB	
2423 012	T. Roll 2: 2nd	*EGB	

2424	[Switch Timing] Switch timing from normal to trailing edge, plain paper 1 (Paper Type, Edge) Paper Type -> N: Normal, Edge ->TE: Trailing Edge		
2424 002	T. Roll 2: N: TE	*EGB	[0 to 200 / 10 / 1 mm/step]
2424 003	Separation: N: TE	*EGB	[0 to 200 / 30 / 1 mm/step]

2426	[Normal: [FC]: LE] Transfer roller current and discharge plate voltage for the leading edge area, plain paper 1, CMY toner Paper side: 1st or 2nd		
2426 003	Separation	*EGB	[0 to 400 / 100 / 5%/step]
2426 007	T. Roll 2: 1st	*EGB	
2426 012	T. Roll 2: 2nd	*EGB	

2428	[Normal: [FC]: TE] Transfer roller current and discharge plate voltage for the trailing edge area, plain paper 1, CMY toner		
2428 003	Separation	*EGB	[0 to 400 / 100 / 5%/step]
2428 007	T. Roll 2: 1st	*EGB	
2428 012	T. Roll 2: 2nd	*EGB	

2432	[Normal2: [K]] Transfer roller current and discharge plate voltage for the image area, plain paper 2, black toner (Process Speed, Paper Side, Unit) Process Speed -> RS: Regular speed, Paper Side: 1st or 2nd Unit -> T.Roll2: Transfer roller, Separat.: Discharge plate (paper separation)		
2432 007	RS: 1st: T. Roll 2	*EGB	Adjusts the transfer roller current. [0 to 60 / 20.0 / 0.1 - μ A/step]
2432 008	RS: 1st: Separat.	*EGB	Adjusts the discharge plate voltage. [0 to 4 / 2.0 / 0.1 -KV/step]
2432 012	RS: 2nd: T. Roll 2	*EGB	[0 to 60 / 10.0 / 0.1 - μ A/step]
2432 013	RS: 2nd: Separat.	*EGB	[0 to 4 / 2.0 / 0.1 -KV/step]

2433	[Normal2: [K]] Transfer roller current and discharge plate voltage for the image area, plain paper 2, black toner (Process Speed, Paper Side) Process Speed -> LS: Low speed, Paper Side: 1st or 2nd		
2433 007	LS: 1st: T. Roll 2	*EGB	Adjusts the transfer roller current. [0 to 60 / 10.0 / 0.1 - μ A/step]
2433 008	LS: 1st: Separa.	*EGB	Adjusts the discharge plate voltage. [0 to 4 / 2.0 / 0.1 -KV/step]
2433 012	LS: 2nd: T. Roll 2	*EGB	[0 to 60 / 7.5 / 0.1 - μ A/step]
2433 013	LS: 2nd: Separa.	*EGB	[0 to 4 / 2.0 / 0.1 -KV/step]

2437	[Normal2: [FC]] Transfer roller current and discharge plate voltage for the image area, plain paper 2, CMY toner (Process Speed, Paper Side) RS: Regular Speed, Paper Side: 1st or 2nd		
2437 013	RS: 1st: T. Roll 2	*EGB	Adjusts the transfer roller current. [0 to 60 / 20.0 / 0.1 - μ A/step]
2437 014	RS: 1st: Separa.	*EGB	Adjusts the discharge plate voltage. [0 to 4 / 2.0 / 0.1 -KV/step]
2437 021	RS: 2nd: T. Roll 2	*EGB	[0 to 60 / 20.0 / 0.1 - μ A/step]
2437 022	RS: 2nd: Separa.	*EGB	[0 to 4 / 2.0 / 0.1 -KV/step]

2438	[Normal2: [FC]] Transfer roller current and discharge plate voltage for the image area, plain paper 2, CMY toner (Process Speed, Paper Side) LS: Low Speed, Paper Side: 1st or 2nd		
2438 013	LS: 1st: T. Roll 2	*EGB	Adjusts the transfer roller current. [0 to 60 / 10.0 / 0.1 - μ A/step]
2438 014	LS: 1st: Separa.	*EGB	Adjusts the discharge plate voltage. [0 to 4 / 2.0 / 0.1 -KV/step]
2438 021	LS: 2nd: T. Roll 2	*EGB	[0 to 60 / 15.0 / 0.1 - μ A/step]
2438 022	LS: 2nd: Separa.	*EGB	[0 to 4 / 2.0 / 0.1 -KV/step]

2451	[Normal2:[K]:LE] Transfer roller current and discharge plate voltage for the leading edge area, plain paper 2, black toner Paper Side: 1st or 2nd Unit -> T.Roll2: Transfer roller, Separation: Discharge plate (paper separation)		
2451 003	Separation	*EGB	[0 to 400 / 100 / 5%/step]
2451 007	Trans.Roll2: 1st	*EGB	
2451 012	Trans.Roll2: 2nd	*EGB	

2452	[Switch Timing] Switch timing from leading edge to normal, plain paper 2 (Paper Type, Edge) Paper Type -> N: Normal, LE: Leading Edge		
2452 002	T. Roll 2: N2: LE	*EGB	[0 to 200 / 10 / 1 mm/step]
2452 003	Separation: N2: LE	*EGB	[0 to 200 / 25 / 1 mm/step]

2453	[Normal2: [K]: TE] Transfer roller current and discharge plate voltage for the trailing edge area, plain paper 2, black toner Paper side: 1st or 2nd Unit -> T.Roll2: Transfer roller, Separation: Discharge plate (paper separation)		
2453 003	Separation	*EGB	[0 to 400 / 100 / 5%/step]
2453 007	T. Roll 2: 1st	*EGB	
2453012	T. Roll 2: 2nd	*EGB	

2454	[Switch Timing] Switch timing from normal to trailing edge, plain paper 2 (Paper Type, Edge) Paper Type -> N: Normal, TE: Trailing Edge		
2454 002	T. Roll 2: N2: TE	*EGB	[0 to 200 / 10 / 1 mm/step]
2454 003	Separation: N2: TE	*EGB	[0 to 200 / 30 / 1 mm/step]

2456	[Normal2:[FC]:LE] Transfer roller current and discharge plate voltage for the leading edge area, plain paper 2, CMY toner Paper Side: 1st or 2nd		
2456 003	Separation	*EGB	[0 to 400 / 100 / 5%/step]
2456 007	T. Roll 2: 1st	*EGB	
2456 012	T. Roll 2: 2nd	*EGB	

2458	[Normal2:[FC]:TE] Transfer roller current and discharge plate voltage for the trailing edge area, plain paper 2, CMY toner Paper Side: 1st or 2nd		
2458 003	Separation	*EGB	[0 to 400 / 100 / 5%/step]
2458 007	T. Roll 2: 1st	*EGB	
2458 012	T. Roll 2: 2nd	*EGB	

2501	[Thick: [K]] Transfer roller current and discharge plate voltage for the image area, thick paper 1, black toner Paper Side: 1st or 2nd Unit -> T.Roll2: Transfer roller, Separa.: Discharge plate (paper separation)		
2501 007	T. Roll 2: 1st	*EGB	Adjusts the transfer roller current. [0 to 60 / 7.5 / 0.1 - μ A/step]
2501 008	Separation: 1st	*EGB	Adjusts the discharge plate voltage. [0 to 4 / 2.0 / 0.1 -KV/step]
2501 012	T. Roll 2: 2nd	*EGB	[0 to 60 / 7.5 / 0.1 - μ A/step]
2501 013	Separation: 2nd	*EGB	[0 to 4 / 2.0 / 0.1 -KV/step]

2506	[Thick: [FC]] Transfer roller current and discharge plate voltage for the image area, thick paper 1, CMY toner Paper Side: 1st or 2 nd		
2506 013	T. Roll 2: 1st	*EGB	Adjusts the transfer roller current. [0 to 60 / 10.0 / 0.1 - μ A/step]
2506 014	Separation: 1st	*EGB	Adjusts the discharge plate voltage. [0 to 4 / 2.0 / 0.1 -KV/step]
2506 021	T. Roll 2: 2nd	*EGB	[0 to 60 / 15.0 / 0.1 - μ A/step]
2506 022	Separation: 2nd	*EGB	[0 to 4 / 2.0 / 0.1 -KV/step]

2521	[Thick: [K]: LE] Transfer roller current and discharge plate voltage for the leading edge area, thick paper 1, black toner Paper Side: 1st or 2 nd		
2521 003	Separation	*EGB	[0 to 400 / 100 / 5%/step]
2521 007	T. Roll 2: 1st	*EGB	
2521 012	T. Roll 2: 2nd	*EGB	

2522	[Switch Timing] Switch timing from leading edge to normal, thick paper 1 (Paper Type, Edge) Paper Type -> TC: Thick, LE: Leading Edge		
2522 002	T. Roll 2: Thick: LE	*EGB	[0 to 200 / 10 / 1 mm/step]
2522 003	Separation: TC: LE	*EGB	[0 to 200 / 25 / 1 mm/step]

2523	[Thick: [K]: TE] Transfer roller current and discharge plate voltage for the trailing edge area, thick paper 1, black toner Paper Side: 1st or 2nd		
2523 003	Separation	*EGB	[0 to 400 / 100 / 5%/step]
2523 007	T. Roll 2: 1st	*EGB	
2523 012	T. Roll 2: 2nd	*EGB	

2524	[Switch Timing] Switch timing from normal to trailing edge, thick paper 1 (Paper Type, Edge) Paper Type -> TC: Thick, TE: Trailing Edge		
2524 002	T. Roll 2: Thick: TE	*EGB	[0 to 200 / 10 / 1 mm/step]
2524 003	Separation: TC: TE	*EGB	[0 to 200 / 30 / 1 mm/step]

2526	[Thick: [FC]: LE] Transfer roller current and discharge plate voltage for the leading edge area, thick paper 1, CMY toner Paper Side: 1st or 2nd		
2526 003	Separation	*EGB	[0 to 400 / 100 / 5%/step]
2526 007	T. Roll 2: 1st	*EGB	
2526 012	T. Roll 2: 2nd	*EGB	

2528	[Thick: [FC]: TE] Transfer roller current and discharge plate voltage for the trailing edge area, thick paper 1, CMY toner Paper Side: 1st or 2nd		
2528 003	Separation	*EGB	[0 to 400 / 100 / 5%/step]
2528 007	T. Roll 2: 1st	*EGB	
2528 012	T. Roll 2: 2nd	*EGB	

2531	[Thick2: [K]] Transfer roller current and discharge plate voltage for the image area, thick paper 2, black toner Unit -> T.Roll2: Transfer roller, Separa.: Discharge plate (paper separation)		
2531 007	Transfer Roller 2	*EGB	Adjusts the transfer roller current. [0 to 60 / 7.5 / 0.1 - μ A/step]
2531 008	Separation	*EGB	Adjusts the discharge plate voltage. [0 to 4 / 2.0 / 0.1 -KV/step]

2536	[Thick2: [FC]] Transfer roller current and discharge plate voltage for the image area, thick paper 2, CMY toner		
2536 013	Transfer Roller 2	*EGB	Adjusts the transfer roller current. [0 to 60 / 10.0 / 0.1 - μ A/step]
2536 014	Separation	*EGB	Adjusts the discharge plate voltage. [0 to 4 / 2.0 / 0.1 -KV/step]

2551	[Thick2: [K]: LE] Transfer roller current and discharge plate voltage for the leading edge area, thick paper 2, black toner		
2551 003	Separation	*EGB	[0 to 400 / 100 / 5%/step]
2551 007	Transfer Roller2	*EGB	

2552	[Switch Timing] Switch timing from leading edge to normal, thick paper 2 (Paper Type, Edge) Paper Type -> TC2: Thick 2, LE: Leading Edge		
2552 002	T. Roll 2: TC2: LE	*EGB	[0 to 200 / 10 / 1 mm/step]
2552 003	Separa.: TC2: LE	*EGB	[0 to 200 / 30 / 1 mm/step]

2553	[Thick2: [K]: TE] Transfer roller current and discharge plate voltage for the trailing edge area, thick paper 2, black toner		
2553 003	Separation	*EGB	[0 to 400 / 100 / 5%/step]
2553 007	Transfer Roller2	*EGB	

2554	[Switch Timing] Switch timing from normal to trailing edge, thick paper 2 (Paper Type, Edge) Paper Type -> TC2: Thick 2, TE: Trailing Edge		
2554 002	T. Roll 2: TC2: TE	*EGB	[0 to 200 / 10 / 1 mm/step]
2554 003	Separa.: TC2: TE	*EGB	[0 to 200 / 30 / 1 mm/step]

2556	[Thick2: [FC]: LE] Transfer roller current and discharge plate voltage for the leading edge area, thick paper 2, CMY toner		
2556 003	Separation	*EGB	[0 to 400 / 100 / 5%/step]
2556 007	Transfer Roller2	*EGB	

2558	[Thick2: [FC]: TE] Transfer roller current and discharge plate voltage for the trailing edge area, thick paper 2, CMY toner		
2558 003	Separation	*EGB	[0 to 400 / 100 / 5%/step]
2558 007	Transfer Roller2	*EGB	

2601	[OHP: [K]] Transfer roller current and discharge plate voltage for the image area, OHP, black toner Unit -> T.Roll2: Transfer roller, Separ.: Discharge plate (paper separation)		
2601 002	Transfer Roller2	*EGB	Adjusts the transfer roller current. [0 to 60 / 15.0 / 0.1 - μ A/step]
2601 003	Separation	*EGB	Adjusts the discharge plate voltage. [0 to 4 / 2.0 / 0.1 -KV/step]

2606	[OHP: [FC]] Transfer roller current and discharge plate voltage for the image area, OHP, CMY toner		
2606 005	Transfer Roller2	*EGB	Adjusts the transfer roller current. [0 to 60 / 15 / 0.1 - μ A/step]
2606 006	Separation	*EGB	Adjusts the discharge plate voltage. [0 to 4 / 2 / 0.1 -KV/step]

2621	[OHP: [K]: LE] Transfer roller current and discharge plate voltage for the leading edge area, OHP, black toner		
2621 002	Transfer Roller2	*EGB	[0 to 400 / 100 / 5%/step]
2621 003	Separation	*EGB	

2622	[Switch Timing] Switch timing from leading edge to normal, OHP (Paper Type, Edge) Paper Type -> OHP, LE: Leading Edge		
2622 002	T. Roll 2: OHP: LE	*EGB	[0 to 200 / 10 / 1 mm/step]
2622 003	Separ.: OHP: LE	*EGB	[0 to 200 / 25 / 1 mm/step]

2623	[OHP: [K]: TE] Transfer roller current and discharge plate voltage for the trailing edge area, OHP, black toner		
2623 002	Transfer Roller2	*EGB	[0 to 400 / 100 / 5%/step]
2623 003	Separation	*EGB	

2624	[Switch Timing] Switch timing from normal to trailing edge, OHP (Paper Type, Edge) Paper Type -> OHP, TE: Trailing Edge		
2624 002	T. Roll 2: OHP: TE	*EGB	[0 to 200 / 10 / 1 mm/step]
2624 003	Separ.: OHP: TE	*EGB	[0 to 200 / 30 / 1 mm/step]

2626	[OHP: [FC]: LE] Transfer roller current and discharge plate voltage for the leading edge area, OHP, CMY toner		
2626 002	Transfer Roller2	*EGB	[0 to 400 / 100 / 5%/step]
2626 003	Separation	*EGB	

2628	[OHP: [FC]: TE] Transfer roller current and discharge plate voltage for the trailing edge area, OHP, CMY toner		
2628 002	Transfer Roller2	*EGB	[0 to 400 / 100 / 5%/step]
2628 003	Separation	*EGB	

2631	[Thin: [K]] Transfer roller current and discharge plate voltage for the image area, thin paper, black toner Unit -> T.Roll2: Transfer roller, Separ.: Discharge plate (paper separation)		
2631 007	Transfer Roller 2	*EGB	Adjusts the transfer roller current. [0 to 60 / 30.0 / 0.1 - μ A/step]
2631 008	Separation	*EGB	Adjusts the discharge plate voltage. [0 to 4 / 2.0 / 0.1 -KV/step]

2633	[Thin: [K]] Transfer roller current and discharge plate voltage for the image area, thin paper, black toner Process Speed -> LS: Low Speed		
2633 007	T.Roll 2: LS	*EGB	Adjusts the transfer roller current. [0 to 60 / 15.0 / 0.5 - μ A/step]
2633 008	Separation: LS	*EGB	Adjusts the discharge plate voltage. [0 to 4 / 2.0 / 0.1 -KV/step]

2636	[Thin: [FC]] Transfer roller current and discharge plate voltage for the image area, thin paper, CMY toner		
2636 013	Transfer Roller 2	*EGB	Adjusts the transfer roller current. [0 to 60 / 25.0 / 0.1 - μ A/step]
2636 014	Separation	*EGB	Adjusts the discharge plate voltage. [0 to 4 / 2.0 / 0.1 -KV/step]

2638	[Thin: [FC]] Transfer roller current and discharge plate voltage for the image area, thin paper, CMY toner Process Speed -> LS: Low Speed		
2638 013	T.Roll 2: LS	*EGB	Adjusts the transfer roller current. [0 to 60 / 17.5 / 0.1 - μ A/step]
2638 014	Separation: LS	*EGB	Adjusts the discharge plate voltage. [0 to 4 / 2.0 / 0.1 -KV/step]

2651	[Thin: [K]: LE] Transfer roller current and discharge plate voltage for the leading edge area, thin paper, black toner		
2651 003	Separation	*EGB	[0 to 400 / 200 / 5%/step]
2651 007	Transfer Roller2	*EGB	[0 to 400 / 100 / 5%/step]

2652	[Switch Timing] Switch timing from leading edge to normal, thin paper (Paper Type, Edge) Paper Type -> TN: Thin, LE: Leading Edge		
2652 002	T. Roll 2: Thin: LE	*EGB	[0 to 200 / 10 / 1 mm/step]
2652 003	Separation: TN: LE	*EGB	[0 to 200 / 25 / 1 mm/step]

2653	[Thin: [K]: TE] Transfer roller current and discharge plate voltage for the trailing edge area, thin paper, black toner		
2653 003	Separation	*EGB	[0 to 400 / 100 / 5%/step]
2653 007	Transfer Roller2	*EGB	

2654	[Switch Timing] Switch timing from normal to trailing edge, thin paper (Paper Type, Edge) Paper Type -> TN: Thin, TE: Trailing Edge		
2654 002	T. Roll 2: Thin: TE	*EGB	[0 to 200 / 10 / 1 mm/step]
2654 003	Separation: TN: TE	*EGB	[0 to 200 / 30 / 1 mm/step]

2656	[Thin: [FC]: LE] Transfer roller current and discharge plate voltage for the leading edge area, thin paper, CMY toner		
2656 003	Separation	*EGB	[0 to 400 / 200 / 5%/step]
2656 007	Transfer Roller2	*EGB	[0 to 400 / 100 / 5%/step]

2658	[Thin: [FC]: TE] Transfer roller current and discharge plate voltage for the trailing edge area, thin paper, CMY toner		
2658 003	Separation	*EGB	[0 to 400 / 100 / 5%/step]
2658 007	Transfer Roller2	*EGB	

2751	[Special: [K]] Transfer roller current and discharge plate voltage for the image area, special paper, black toner Paper Side: 1st or 2nd		
2751 007	T.Roll 2: 1st	*EGB	Adjusts the transfer roller current. [0 to 60 / 5.0 / 0.1 - μ A/step]
2751 008	Separation: 1st	*EGB	Adjusts the discharge plate voltage. [0 to 4 / 2.0 / 0.1 -KV/step]

2756	[Special: [FC]] Transfer roller current and discharge plate voltage for the image area, special paper, CMY toner Paper Side: 1st or 2nd		
2756 013	T.Roll 2: 1st	*EGB	Adjusts the transfer roller current. [0 to 60 / 5.0 / 0.1 - μ A/step]
2756 014	Separation: 1st	*EGB	Adjusts the discharge plate voltage. [0 to 4 / 2.0 / 0.1 -KV/step]

2771	[Special: [K]: LE] Transfer roller current and discharge plate voltage for the leading edge area, special paper, black toner Paper Side: 1st or 2nd		
2771 003	Separation	*EGB	[0 to 400 / 100 / 5%/step]
2771 007	T.Roll 2: 1st	*EGB	

2773	[Special: [K]: TE] Transfer roller current and discharge plate voltage for the trailing edge area, special paper, black toner Paper Side: 1st or 2nd		
2773 003	Separation	*EGB	[0 to 400 / 100 / 5%/step]
2773 007	T.Roll 2: 1st	*EGB	

2776	[SP: [FC]: LE] Transfer roller current and discharge plate voltage for the leading edge area, special paper, CMY toner Paper Side: 1st or 2nd		
2776 003	Separation	*EGB	[0 to 400 / 100 / 5%/step]
2776 007	T.Roll 2: 1st	*EGB	

2778	[SP: [FC]: TE] Transfer roller current and discharge plate voltage for the trailing edge area, special paper, CMY toner Paper Side: 1st or 2nd		
2778 003	Separation	*EGB	[0 to 400 / 100 / 5%/step]
2778 007	T.Roll 2: 1st	*EGB	

2901	[T2: N: Size 4] Transfer Roller Current: Correction for Humidity, Plain paper 1, Paper width between A5 and A6 (Environment, Process Speed, [Color], Paper Side) LS: Low Speed, RS: Regular Speed, Paper Side: 1st or 2nd		
2901 001	LL: RS [K]: 1st	*EGB	[0 to 1275 / 100 / 5%/step]
2901 002	LL: RS [K]: 2nd	*EGB	[0 to 1275 / 350 / 5%/step]
2901 003	LL: RS [FC]: 1st	*EGB	[0 to 1275 / 130 / 5%/step]
2901 004	LL: RS [FC]: 2nd	*EGB	[0 to 1275 / 170 / 5%/step]
2901 005	LL: LS [K]: 1st	*EGB	[0 to 1275 / 150 / 5%/step]
2901 006	LL: LS [K]: 2nd	*EGB	[0 to 1275 / 280 / 5%/step]
2901 007	LL: LS [FC]: 1st	*EGB	[0 to 1275 / 120 / 5%/step]
2901 008	LL: LS [FC]: 2nd	*EGB	[0 to 1275 / 170 / 5%/step]
2901 009	MM: RS [K]: 1st	*EGB	[0 to 1275 / 80 / 5%/step]
2901 010	MM: RS [K]: 2nd	*EGB	[0 to 1275 / 480 / 5%/step]
2901 011	MM: RS [FC]: 1st	*EGB	[0 to 1275 / 100 / 5%/step]
2901 012	MM: RS [FC]: 2nd	*EGB	[0 to 1275 / 190 / 5%/step]
2901 013	MM: LS [K]: 1st	*EGB	[0 to 1275 / 100 / 5%/step]
2901 014	MM: LS [K]: 2nd	*EGB	[0 to 1275 / 400 / 5%/step]
2901 015	MM: LS [FC]: 1st	*EGB	[0 to 1275 / 90 / 5%/step]
2901 016	MM: LS [FC]: 2nd	*EGB	[0 to 1275 / 180 / 5%/step]
2901 017	HH: RS [K]: 1st	*EGB	[0 to 1275 / 100 / 5%/step]
2901 018	HH: RS [K]: 2nd	*EGB	[0 to 1275 / 220 / 5%/step]

2901 019	HH: RS [FC]: 1st	*EGB	[0 to 1275 / 110 / 5%/step]
2901 020	HH: RS [FC]: 2nd	*EGB	[0 to 1275 / 170 / 5%/step]
2901 021	HH: LS [K]: 1st	*EGB	[0 to 1275 / 60 / 5%/step]
2901 022	HH: LS [K]: 2nd	*EGB	[0 to 1275 / 110 / 5%/step]
2901 023	HH: LS [FC]: 1st	*EGB	[0 to 1275 / 70 / 5%/step]
2901 024	HH: LS [FC]: 2nd	*EGB	[0 to 1275 / 120 / 5%/step]

2902	[T2: N: Size 5] Transfer Roller Current: Correction for Humidity, Plain paper 1, Paper width A6 or less (Environment, Process Speed, [Color], Paper Side) LS: Low Speed, RS: Regular Speed, Paper Side: 1st or 2nd			
	2902 001	LL: RS [K]: 1st	*EGB	[0 to 1275 / 150 / 5%/step]
	2902 002	LL: RS [K]: 2nd	*EGB	[0 to 1275 / 400 / 5%/step]
	2902 003	LL: RS [FC]: 1st	*EGB	[0 to 1275 / 200 / 5%/step]
	2902 004	LL: RS [FC]: 2nd	*EGB	[0 to 1275 / 190 / 5%/step]
	2902 005	LL: LS [K]: 1st	*EGB	[0 to 1275 / 200 / 5%/step]
	2902 006	LL: LS [K]: 2nd	*EGB	[0 to 1275 / 400 / 5%/step]
	2902 007	LL: LS [FC]: 1st	*EGB	[0 to 1275 / 160 / 5%/step]
	2902 008	LL: LS [FC]: 2nd	*EGB	[0 to 1275 / 240 / 5%/step]
	2902 009	MM: RS [K]: 1st	*EGB	[0 to 1275 / 120 / 5%/step]
	2902 010	MM: RS [K]: 2nd	*EGB	[0 to 1275 / 480 / 5%/step]
	2902 011	MM: RS [FC]: 1st	*EGB	[0 to 1275 / 150 / 5%/step]
	2902 012	MM: RS [FC]: 2nd	*EGB	[0 to 1275 / 190 / 5%/step]
	2902 013	MM: LS [K]: 1st	*EGB	[0 to 1275 / 170 / 5%/step]
	2902 014	MM: LS [K]: 2nd	*EGB	[0 to 1275 / 500 / 5%/step]
	2902 015	MM: LS [FC]: 1st	*EGB	[0 to 1275 / 140 / 5%/step]
	2902 016	MM: LS [FC]: 2nd	*EGB	[0 to 1275 / 220 / 5%/step]
	2902 017	HH: RS [K]: 1st	*EGB	[0 to 1275 / 130 / 5%/step]
	2902 018	HH: RS [K]: 2nd	*EGB	[0 to 1275 / 220 / 5%/step]
	2902 019	HH: RS [FC]: 1st	*EGB	[0 to 1275 / 150 / 5%/step]
	2902 020	HH: RS [FC]: 2nd	*EGB	[0 to 1275 / 200 / 5%/step]
	2902 021	HH: LS [K]: 1st	*EGB	[0 to 1275 / 90 / 5%/step]
	2902 022	HH: LS [K]: 2nd	*EGB	[0 to 1275 / 140 / 5%/step]
	2902 023	HH: LS [FC]: 1st	*EGB	[0 to 1275 / 110 / 5%/step]
	2902 024	HH: LS [FC]: 2nd	*EGB	[0 to 1275 / 150 / 5%/step]

2903	[T2: N2: Size 4] Transfer Roller Current: Correction for Humidity, Plain paper 2 Paper width between A5 and A6 (Environment, Process Speed, [Color], Paper Side) LS: Low Speed, RS: Regular Speed, Paper Side: 1st or 2nd			
	2903 001	LL: RS [K]: 1st	*EGB	[0 to 1275 / 130 / 5%/step]
	2903 002	LL: RS [K]: 2nd	*EGB	[0 to 1275 / 440 / 5%/step]
	2903 003	LL: RS [FC]: 1st	*EGB	[0 to 1275 / 130 / 5%/step]
	2903 004	LL: RS [FC]: 2nd	*EGB	[0 to 1275 / 230 / 5%/step]
	2903 005	LL: LS [K]: 1st	*EGB	[0 to 1275 / 200 / 5%/step]
	2903 006	LL: LS [K]: 2nd	*EGB	[0 to 1275 / 280 / 5%/step]
	2903 007	LL: LS [FC]: 1st	*EGB	[0 to 1275 / 120 / 5%/step]
	2903 008	LL: LS [FC]: 2nd	*EGB	[0 to 1275 / 210 / 5%/step]

2903 009	MM: RS [K]: 1st	*EGB	[0 to 1275 / 100 / 5%/step]
2903 010	MM: RS [K]: 2nd	*EGB	[0 to 1275 / 600 / 5%/step]
2903 011	MM: RS [FC]: 1st	*EGB	[0 to 1275 / 100 / 5%/step]
2903 012	MM: RS [FC]: 2nd	*EGB	[0 to 1275 / 300 / 5%/step]
2903 013	MM: LS [K]: 1st	*EGB	[0 to 1275 / 150 / 5%/step]
2903 014	MM: LS [K]: 2nd	*EGB	[0 to 1275 / 530 / 5%/step]
2903 015	MM: LS [FC]: 1st	*EGB	[0 to 1275 / 150 / 5%/step]
2903 016	MM: LS [FC]: 2nd	*EGB	[0 to 1275 / 270 / 5%/step]
2903 017	HH: RS [K]: 1st	*EGB	[0 to 1275 / 120 / 5%/step]
2903 018	HH: RS [K]: 2nd	*EGB	[0 to 1275 / 270 / 5%/step]
2903 019	HH: RS [FC]: 1st	*EGB	[0 to 1275 / 110 / 5%/step]
2903 020	HH: RS [FC]: 2nd	*EGB	[0 to 1275 / 220 / 5%/step]
2903 021	HH: LS [K]: 1st	*EGB	[0 to 1275 / 80 / 5%/step]
2903 022	HH: LS [K]: 2nd	*EGB	[0 to 1275 / 150 / 5%/step]
2903 023	HH: LS [FC]: 1st	*EGB	[0 to 1275 / 90 / 5%/step]
2903 024	HH: LS [FC]: 2nd	*EGB	[0 to 1275 / 180 / 5%/step]

2904	[T2: N2: Size 5] Transfer Roller Current: Correction for Humidity, Plain paper 2, Paper width A6 or less (Environment, Process Speed, [Color], Paper Side) LS: Low Speed, RS: Regular Speed, Paper Side: 1st or 2nd		
	2904 001	LL: RS [K]: 1st	*EGB
2904 002	LL: RS [K]: 2nd	*EGB	[0 to 1275 / 500 / 5%/step]
2904 003	LL: RS [FC]: 1st	*EGB	[0 to 1275 / 200 / 5%/step]
2904 004	LL: RS [FC]: 2nd	*EGB	[0 to 1275 / 270 / 5%/step]
2904 005	LL: LS [K]: 1st	*EGB	[0 to 1275 / 270 / 5%/step]
2904 006	LL: LS [K]: 2nd	*EGB	[0 to 1275 / 400 / 5%/step]
2904 007	LL: LS [FC]: 1st	*EGB	[0 to 1275 / 160 / 5%/step]
2904 008	LL: LS [FC]: 2nd	*EGB	[0 to 1275 / 300 / 5%/step]
2904 009	MM: RS [K]: 1st	*EGB	[0 to 1275 / 150 / 5%/step]
2904 010	MM: RS [K]: 2nd	*EGB	[0 to 1275 / 600 / 5%/step]
2904 011	MM: RS [FC]: 1st	*EGB	[0 to 1275 / 150 / 5%/step]
2904 012	MM: RS [FC]: 2nd	*EGB	[0 to 1275 / 300 / 5%/step]
2904 013	MM: LS [K]: 1st	*EGB	[0 to 1275 / 250 / 5%/step]
2904 014	MM: LS [K]: 2nd	*EGB	[0 to 1275 / 670 / 5%/step]
2904 015	MM: LS [FC]: 1st	*EGB	[0 to 1275 / 250 / 5%/step]
2904 016	MM: LS [FC]: 2nd	*EGB	[0 to 1275 / 330 / 5%/step]
2904 017	HH: RS [K]: 1st	*EGB	[0 to 1275 / 160 / 5%/step]
2904 018	HH: RS [K]: 2nd	*EGB	[0 to 1275 / 270 / 5%/step]
2904 019	HH: RS [FC]: 1st	*EGB	[0 to 1275 / 150 / 5%/step]
2904 020	HH: RS [FC]: 2nd	*EGB	[0 to 1275 / 240 / 5%/step]
2904 021	HH: LS [K]: 1st	*EGB	[0 to 1275 / 120 / 5%/step]
2904 022	HH: LS [K]: 2nd	*EGB	[0 to 1275 / 180 / 5%/step]
2904 023	HH: LS [FC]: 1st	*EGB	[0 to 1275 / 130 / 5%/step]
2904 024	HH: LS [FC]: 2nd	*EGB	[0 to 1275 / 250 / 5%/step]

2905	[T2: Thin: Size4] Transfer Roller Current: Correction for Humidity, Thin Paper, Paper width between A5 and A6 (Environment, Process Speed, [Color]) LS: Low Speed, RS: Regular Speed		
2905 001	LL: RS [K]	*EGB	[0 to 1275 / 80 / 5%/step]
2905 002	LL: RS [FC]	*EGB	[0 to 1275 / 130 / 5%/step]
2905 003	LL: LS [K]	*EGB	[0 to 1275 / 150 / 5%/step]
2905 004	LL: LS [FC]	*EGB	[0 to 1275 / 120 / 5%/step]
2905 005	MM: RS [K]	*EGB	[0 to 1275 / 70 / 5%/step]
2905 006	MM: RS [FC]	*EGB	[0 to 1275 / 80 / 5%/step]
2905 007	MM: LS [K]	*EGB	[0 to 1275 / 100 / 5%/step]
2905 008	MM: LS [FC]	*EGB	[0 to 1275 / 90 / 5%/step]
2905 009	HH: RS [K]	*EGB	[0 to 1275 / 90 / 5%/step]
2905 010	HH: RS [FC]	*EGB	[0 to 1275 / 130 / 5%/step]
2905 011	HH: LS [K]	*EGB	[0 to 1275 / 60 / 5%/step]
2905 012	HH: LS [FC]	*EGB	[0 to 1275 / 130 / 5%/step]

2906	[T2: Thin: Size5] Transfer Roller Current: Correction for Humidity, Thin paper, Paper width A6 or less (Environment, Process Speed, [Color]) LS: Low Speed, RS: Regular Speed		
2906 001	LL: RS [K]	*EGB	[0 to 1275 / 130 / 5%/step]
2906 002	LL: RS [FC]	*EGB	[0 to 1275 / 200 / 5%/step]
2906 003	LL: LS [K]	*EGB	[0 to 1275 / 200 / 5%/step]
2906 004	LL: LS [FC]	*EGB	[0 to 1275 / 160 / 5%/step]
2906 005	MM: RS [K]	*EGB	[0 to 1275 / 100 / 5%/step]
2906 006	MM: RS [FC]	*EGB	[0 to 1275 / 120 / 5%/step]
2906 007	MM: LS [K]	*EGB	[0 to 1275 / 170 / 5%/step]
2906 008	MM: LS [FC]	*EGB	[0 to 1275 / 140 / 5%/step]
2906 009	HH: RS [K]	*EGB	[0 to 1275 / 110 / 5%/step]
2906 010	HH: RS [FC]	*EGB	[0 to 1275 / 180 / 5%/step]
2906 011	HH: LS [K]	*EGB	[0 to 1275 / 90 / 5%/step]
2906 012	HH: LS [FC]	*EGB	[0 to 1275 / 200 / 5%/step]

2907	[T2: TC: Size4] Transfer Roller Current: Correction for Humidity, Thick Paper 1, Paper width between A5 and A6 (Environment, Process Speed, [Color], Paper Side) LS: Low Speed, RS: Regular Speed, Paper Side: 1st or 2nd		
2907 001	LL: LS [K]: 1st	*EGB	[0 to 1275 / 150 / 5%/step]
2907 002	LL: LS [K]: 2nd	*EGB	[0 to 1275 / 270 / 5%/step]
2907 003	LL: LS [FC]: 1st	*EGB	[0 to 1275 / 150 / 5%/step]
2907 004	LL: LS [FC]: 2nd	*EGB	[0 to 1275 / 270 / 5%/step]
2907 005	MM: LS [K]: 1st	*EGB	[0 to 1275 / 270 / 5%/step]
2907 006	MM: LS [K]: 2nd	*EGB	[0 to 1275 / 530 / 5%/step]
2907 007	MM: LS [FC]: 1st	*EGB	[0 to 1275 / 200 / 5%/step]
2907 008	MM: LS [FC]: 2nd	*EGB	[0 to 1275 / 270 / 5%/step]
2907 009	HH: LS [K]: 1st	*EGB	[0 to 1275 / 100 / 5%/step]
2907 010	HH: LS [K]: 2nd	*EGB	[0 to 1275 / 110 / 5%/step]
2907 011	HH: LS [FC]: 1st	*EGB	[0 to 1275 / 120 / 5%/step]
2907 012	HH: LS [FC]: 2nd	*EGB	[0 to 1275 / 110 / 5%/step]

2908	[T2: TC: Size5] Transfer Roller Current: Correction for Humidity, Thick paper 1, Paper width A6 or less (Environment, Process Speed, [Color], Paper Side) LS: Low Speed, RS: Regular Speed, Paper Side: 1st or 2nd		
2908 001	LL: LS [K]: 1st	*EGB	[0 to 1275 / 150 / 5%/step]
2908 002	LL: LS [K]: 2nd	*EGB	[0 to 1275 / 400 / 5%/step]
2908 003	LL: LS [FC]: 1st	*EGB	[0 to 1275 / 150 / 5%/step]
2908 004	LL: LS [FC]: 2nd	*EGB	[0 to 1275 / 400 / 5%/step]
2908 005	MM: LS [K]: 1st	*EGB	[0 to 1275 / 270 / 5%/step]
2908 006	MM: LS [K]: 2nd	*EGB	[0 to 1275 / 530 / 5%/step]
2908 007	MM: LS [FC]: 1st	*EGB	[0 to 1275 / 200 / 5%/step]
2908 008	MM: LS [FC]: 2nd	*EGB	[0 to 1275 / 270 / 5%/step]
2908 009	HH: LS [K]: 1st	*EGB	[0 to 1275 / 130 / 5%/step]
2908 010	HH: LS [K]: 2nd	*EGB	[0 to 1275 / 170 / 5%/step]
2908 011	HH: LS [FC]: 1st	*EGB	[0 to 1275 / 160 / 5%/step]
2908 012	HH: LS [FC]: 2nd	*EGB	[0 to 1275 / 170 / 5%/step]

2909	[T2: TC2: Size4] Transfer Roller Current: Correction for Humidity, Thick Paper 2, Paper width between A5 and A6 (Environment, Process Speed, [Color]) LS: Low Speed, RS: Regular Speed		
2909 001	LL: LS [K]	*EGB	[0 to 1275 / 150 / 5%/step]
2909 002	LL: LS [FC]	*EGB	[0 to 1275 / 150 / 5%/step]
2909 003	MM: LS [K]	*EGB	[0 to 1275 / 270 / 5%/step]
2909 004	MM: LS [FC]	*EGB	[0 to 1275 / 200 / 5%/step]
2909 005	HH: LS [K]	*EGB	[0 to 1275 / 100 / 5%/step]
2909 006	HH: LS [FC]	*EGB	[0 to 1275 / 120 / 5%/step]

2910	[T2: TC2: Size5] Transfer Roller Current: Correction for Humidity, Thick paper 2, Paper width A6 or less (Environment, Process Speed, [Color]) LS: Low Speed, RS: Regular Speed		
2910 001	LL: LS [K]	*EGB	[0 to 1275 / 150 / 5%/step]
2910 002	LL: LS [FC]	*EGB	[0 to 1275 / 150 / 5%/step]
2910 003	MM: LS [K]	*EGB	[0 to 1275 / 270 / 5%/step]
2910 004	MM: LS [FC]	*EGB	[0 to 1275 / 200 / 5%/step]
2910 005	HH: LS [K]	*EGB	[0 to 1275 / 130 / 5%/step]
2910 006	HH: LS [FC]	*EGB	[0 to 1275 / 160 / 5%/step]

2911	[T2: SP Size4] Transfer Roller Current: Correction for Humidity, Special paper, Paper width between A5 and A6 (Environment, Process Speed, [Color]) LS: Low Speed, RS: Regular Speed		
2911 001	LL: LS [K]	*EGB	[0 to 1275 / 200 / 5%/step]
2911 002	LL: LS [FC]	*EGB	[0 to 1275 / 200 / 5%/step]
2911 003	MM: LS [K]	*EGB	[0 to 1275 / 400 / 5%/step]
2911 004	MM: LS [FC]	*EGB	[0 to 1275 / 400 / 5%/step]
2911 005	HH: LS [K]	*EGB	[0 to 1275 / 150 / 5%/step]
2911 006	HH: LS [FC]	*EGB	[0 to 1275 / 150 / 5%/step]

2912	[T2: SP: Size5] Transfer Roller Current: Correction for Humidity, Special paper, Paper width A6 or less (Environment, Process Speed, [Color]) LS: Low Speed, RS: Regular Speed		
2912 001	LL: LS [K]	*EGB	[0 to 1275 / 200 / 5%/step]
2912 002	LL: LS [FC]	*EGB	[0 to 1275 / 200 / 5%/step]
2912 003	MM: LS [K]	*EGB	[0 to 1275 / 400 / 5%/step]
2912 004	MM: LS [FC]	*EGB	[0 to 1275 / 400 / 5%/step]
2912 005	HH: LS [K]	*EGB	[0 to 1275 / 200 / 5%/step]
2912 006	HH: LS [FC]	*EGB	[0 to 1275 / 200 / 5%/step]

2920	[S: HH SP: 1st] Smaller than A5 HH Special paper, 1 st side		
2920 001	T2 Switch Timing	*EGB	[0 to 200 / 15 / 1 mm/step]
2920 002	T2 Correction	*EGB	[0 to 1275 / 20 / 5%/step]

2921	[S: HH SP: 2nd] Smaller than A5 HH Special paper, 2 nd side		
2921 001	T2 Switch Timing	*EGB	[0 to 200 / 15 / 1 mm/step]
2921 002	T2 Correction	*EGB	[0 to 1275 / 0 / 5%/step]

2930	[Separa. : LE: HH] Separation Voltage: Correction for HH Humidity at the Leading Edge (Paper Type, Process Speed, [Color]) Paper Type -> Normal, Thin Process Speed -> LS: Low speed, RS: Regular speed		
2930 001	Normal: RS: [K]	*EGB	[0 to 400 / 200 / 5%/step]
2930 002	Normal: RS: [FC]	*EGB	
2930 003	Normal: LS: [K]	*EGB	
2930 004	Normal: LS: [FC]	*EGB	
2930 005	Normal 2: RS: [K]	*EGB	
2930 006	Normal 2: RS: [FC]	*EGB	
2930 007	Normal 2: LS: [K]	*EGB	
2930 008	Normal 2: LS: [FC]	*EGB	
2930 009	Thin: RS: [K]	*EGB	
2930 010	Thin: RS: [FC]	*EGB	
2930 011	Thin: LS: [K]	*EGB	
2930 012	Thin: LS: [FC]	*EGB	

SP3-XXX (Process)

3001	[Vt Display] Vt Display ([Color])		
3001 001	[K]	*EGB	Displays the output voltage of TD sensor for each color. [0.00 to 5.00 / 0.01 / 0.01 V/step]
3001 002	[M]	*EGB	
3001 003	[C]	*EGB	
3001 004	[Y]	*EGB	

3002	[Vcnt Current] Current Vcnt Display ([Color])		
3002 001	[K]	*EGB	Displays the current Vcnt for each color. [0.00 to 5.00 / 3.00 / 0.01 V/step]
3002 002	[M]	*EGB	
3002 003	[C]	*EGB	
3002 004	[Y]	*EGB	
	[Vcnt Initial] Initial Vcnt Display ([Color])		
3002 005	[K]	*EGB	Displays the initial Vcnt for each color. [0.00 to 5.00 / 3.00 / 0.01 V/step]
3002 006	[M]	*EGB	
3002 007	[C]	*EGB	
3002 008	[Y]	*EGB	

3003	[Vtref Current] Current Vtref Display ([Color])		
3003 001	[K]	*EGB	Displays the current Vtref for each color. [0.00 to 5.00 / 3.00 / 0.01 V/step]
3003 002	[M]	*EGB	
3003 003	[C]	*EGB	
3003 004	[Y]	*EGB	
	[Vtref Initial] Initial Vtref Display ([Color])		
3003 005	[K]	*EGB	Displays the initial Vtref for each color. [0.00 to 5.00 / 3.00 / 0.01 V/step]
3003 006	[M]	*EGB	
3003 007	[C]	*EGB	
3003 008	[Y]	*EGB	

3011	[T. Sensor Init.] Toner Density Sensor Initial Setting (Agitation Time, TS Target: Toner Sensor Target Value, [Color])		
3011 001	Agitation: [K]	*EGB	Adjusts the agitation time for the developer for each color. [0 to 300 / 65 / 1 sec/step]
3011 002	Agitation: [M]	*EGB	
3011 003	Agitation: [C]	*EGB	
3011 004	Agitation: [Y]	*EGB	
3011 005	TD Target: [K]	*EGB	Adjusts the TS initial target voltage for each color. [0.00 to 5.00 / 2.50 / 0.01 V/step]
3011 006	TD Target: [M]	*EGB	
3011 007	TD Target: [C]	*EGB	
3011 008	TD Target: [Y]	*EGB	

3021	[Vt Shift] Vt Shift Setting ([Color])		
3021 001	[K]	*EGB	Adjusts the Vt shift rate for each color. [0.00 to 5.00 / 0.75 / 0.01 V/step]
3021 002	[M]	*EGB	
3021 003	[C]	*EGB	
3021 004	[Y]	*EGB	

3041	[Vtref] Vtref Setting ([Color])		
3041 001	Lower Limit: [K]	*EGB	Sets the lower limit Vtref voltage for each color. [0.10 to 5.00 / 1.50 / 0.01 V/step]
3041 002	Lower Limit: [M]	*EGB	
3041 003	Lower Limit: [C]	*EGB	
3041 004	Lower Limit: [Y]	*EGB	
3041 005	Upper Limit: [K]	*EGB	DFU
3041 006	Upper Limit: [M]	*EGB	Sets the maximum limit Vtref voltage for each color. [0.10 to 5.00 / 3.70 / 0.01 V/step]
3041 007	Upper Limit: [C]	*EGB	
3041 008	Upper Limit: [Y]	*EGB	

3042	[Vtref] Vtref Correction Setting ([Color]) DFU		
3042 001	Mode	*EGB	Sets the Vtref correction. [0 or 1 / 1 / -] Alphanumeric 0: On, 1: Off
3042 002	Step [K]	*EGB	Adjusts the Vtref correction step for each color. [0.00 to 1.00 / 0.10 / 0.01 V/step]
3042 003	Step [M]	*EGB	
3042 004	Step [C]	*EGB	
3042 005	Step [Y]	*EGB	
3042 014	Change Step: [K]	*EGB	Adjusts the density change rate of the ID sensor pattern for each color. [0 to 100 / 10 / 1%/step]
3042 015	Change Step: [M]	*EGB	
3042 016	Change Step: [C]	*EGB	
3042 017	Change Step: [Y]	*EGB	

3101	[P. Sensor Patt.] ID Sensor Pattern Density Setting ([Color])		
3101 001	Change Value: [K]	*EGB	Displays the density change rate of the ID sensor pattern for each color. [-100 to 100 / 0 / 1%/step]
3101 002	Change Value: [M]	*EGB	
3101 003	Change Value: [C]	*EGB	
3101 004	Change Value: [Y]	*EGB	

3111	[Voff Display] Vsp-offset Display		
3111 001	Regular	*EGB	Displays the Vsp-offset regular voltage. [0.00 to 5.00 / 0.00 / 0.01 V/step]
3111 002	Diffusion	*EGB	Displays the Vsp-offset diffusion voltage. [0.00 to 5.00 / 0.00 / 0.01 V/step]

3121	[Vsg Display] Vsg Display		
3121 001	Regular	*EGB	Displays the Vsp regular voltage. [0.00 to 5.00 / 0.00 / 0.01 V/step]
3121 002	Diffusion		Displays the Vsp diffusion voltage. [0.00 to 5.00 / 0.00 / 0.01 V/step]

3131	[Lps Display] lps Display		
3131 001	Lps	*EGB	Displays the lps. [0 to 511 / 0 / 1/step]

3141	[Vmin Display]		
3141 001	[K]	*EGB	Displays the Vmin voltage for each color. [0.00 to 5.00 / 0.00 / 0.01 V/step]
3141 005	[Cl]	*EGB	

3142	[Kx Display]		
3142 001	Min	*EGB	Displays the minimum Kx. [0.0000 to 1.0000 / 0.0000 / 0.0001/step]

3143	[K5 Display] ([Color])		
3143 002	[M]	*EGB	Displays the P.sensor K5 for each color. [0.0000 to 5.0000 / 1.2500 / 0.0001/step]
3143 003	[C]	*EGB	
3143 004	[Y]	*EGB	

3145	[Vmin]		
3145 001	Upper Limit	*EGB	DFU Adjusts the maximum Vmin. [0.00 to 5.00 / 0.05 / 0.01 V/step]

3146	[K2]		
3146 001	Upper Limit	*EGB	DFU Adjusts the upper limit. [0.0000 to 1.0000 / 0.1500 / 0.0001/step]
3146 002	Lower Limit	*EGB	DFU Adjusts the lower limit. [0.0000 to 1.0000 / 0.0500 / 0.0001/step]

3147	[K5]		
3147 001	Upper Limit	*EGB	DFU Adjusts the upper limit. [0.0000 to 5.0000 / 2.5000 / 0.0001/step]
3147 002	Lower Limit	*EGB	DFU Adjusts the lower limit. [0.0000 to 5.0000 / 0.7500 / 0.0001/step]

3148	[P sensor Prm.] ID sensor Parameter		
3148 001	setting	*EGB	DFU [0 to 8.0000 / 4.600 / 0.001/step]

3151	[Vsg Display] ([Color])		
3151 001	Regular: [K]	*EGB	Displays the Vsg output from ID sensor for each mode. [0.00 to 5.00 / 0.00 / 0.01 V/step]
3151 002	Regular: [M]	*EGB	
3151 003	Regular: [C]	*EGB	
3151 004	Regular: [Y]	*EGB	

3151 005	Diffusion: [K]	*EGB	Displays the Vsg output from ID sensor for each mode. [0.00 to 5.00 / 0.00 / 0.01 V/step]
3151 006	Diffusion: [M]	*EGB	
3151 007	Diffusion: [C]	*EGB	
3151 008	Diffusion: [Y]	*EGB	

3161	[P. Pattern] ID Sensor Pattern Setting ([Color]) DFU		
3161 001	Target Value: [K]	*EGB	Adjusts the target voltage of ID sensor pattern for each mode. [0 to 100 / 50 / 1%/step]
3161 002	Target Value: [M]	*EGB	
3161 003	Target Value: [C]	*EGB	
3161 004	Target Value: [Y]	*EGB	

3171	[P. Pattern] ID Sensor Pattern Setting ([Color]) DFU		
3171 001	Interval: [K]	*EGB	Adjusts the interval of making the ID sensor pattern. [0 to 200 / 60 / 1 sheet/step]
3171 002	Interval: [MCY]	*EGB	

3201	[Toner Near End] Toner Near End ([Color]) DFU		
3201 001	Sensor: [K]		Displays the output from the toner end sensor. [0.0 to 5.0 / 0.0 / 0.1 V/step]
3201 002	Sensor: [M]		
3201 003	Sensor: [C]		
3201 004	Sensor: [Y]		

3202	[Toner Near End] Toner Near End ([Color])		
3202 001	Counter: [K]	*EGB	Displays the counter of the toner near end for each mode. [0 to 30 / 0 / 1/step]
3202 002	Counter: [M]	*EGB	
3202 003	Counter: [C]	*EGB	
3202 004	Counter: [Y]	*EGB	

3301	[Toner Mode] Toner Supply Control ([Color])		
3301 001	[K]	*EGB	Selects the method of the toner supply for each mode. [0 to 3 / 3 / 1/step] 0: Fixed, 1: Coefficient (Pixel), 2: Coefficient (TD sensor), 3: Hybrid ●6.2.5
3301 002	[M]	*EGB	
3301 003	[C]	*EGB	
3301 004	[Y]	*EGB	

3302	[Toner Mode] Toner Supply Control ([Color])		
3302 001	Fixed Rate: [K]	*EGB	Adjusts the toner supply rate for each mode. These SPs are enabled only when SP3301 for each color is set to "0". [0 to 100 / 5 / 1%/step]
3302 002	Fixed Rate: [M]	*EGB	
3302 003	Fixed Rate: [C]	*EGB	
3302 004	Fixed Rate: [Y]	*EGB	

3303	[Toner Mode] Toner Supply Control ([Color])		
3303 001	T. Supply Rate: [K]	*EGB	Displays the toner supply rate for each

3303 002	T. Supply Rate: [M]	*EGB	mode. [0 to 100 / 0 / 1%/step]
3303 003	T. Supply Rate: [C]	*EGB	
3303 004	T. Supply Rate: [Y]	*EGB	

3304	[Toner Mode] Toner Supply Control ([Color])		
3304 001	Upper Limit: [K]	*EGB	Adjusts the upper limit of toner supply rate for each mode. [0 to 100 / 100 / 1%/step]
3304 002	Upper Limit: [M]	*EGB	
3304 003	Upper Limit: [C]	*EGB	
3304 004	Upper Limit: [Y]	*EGB	
3304 005	Lower Limit: [K]	*EGB	Adjusts the lower limit of toner supply rate for each mode. [0 to 800/ 100/ 10 msec/step]
3304 006	Lower Limit: [M]	*EGB	
3304 007	Lower Limit: [C]	*EGB	
3304 008	Lower Limit: [Y]	*EGB	

3306	[Toner Mode] Toner Supply Control ([Color])		
3306 001	Coefficient 1: [K]	*EGB	Adjusts the time of the toner supply in proportional control mode (Pixel). [0.10 to 5.00 / 1.00 / 0.01/step]
3306 002	Coefficient 1: [M]	*EGB	
3306 003	Coefficient 1: [C]	*EGB	
3306 004	Coefficient 1: [Y]	*EGB	
3306 005	Coefficient 2: [K]	*EGB	Adjusts the time of the toner supply in proportional control mode (TD sensor). [0.10 to 5.00 / 0.3 / 0.01/step]
3306 006	Coefficient 2: [M]	*EGB	
3306 007	Coefficient 2: [C]	*EGB	
3306 008	Coefficient 2: [Y]	*EGB	
3306 009	Coefficient 3: [K]	*EGB	Adjusts the time of the toner supply in hybrid control mode. [0.10 to 5.00 / 0.4 / 0.01/step]
3306 010	Coefficient 3: [M]	*EGB	
3306 011	Coefficient 3: [C]	*EGB	
3306 012	Coefficient 3: [Y]	*EGB	
3306 013	Coefficient 4: [K]	*EGB	Adjusts the time of the toner supply in hybrid control mode. [0.10 to 5.00 / 0.1 / 0.01/step]
3306 014	Coefficient 4: [M]	*EGB	
3306 015	Coefficient 4: [C]	*EGB	
3306 016	Coefficient 4: [Y]	*EGB	
3306 017	Coefficient 5: [K]	*EGB	Adjusts the time of the toner supply in hybrid control mode. [0.10 to 5.00 / 0.80/ 0.01/step]
3306 018	Coefficient 5: [M]	*EGB	
3306 019	Coefficient 5: [C]	*EGB	
3306 020	Coefficient 5: [Y]	*EGB	

3401	[Toner End Detec] Toner End Detection		
3401 001		*EGB	[0 or 1 / 0 / -] 0: Detect, 1: Not detect

3411	[Toner Near End] ([Color]) DFU		
3411 001	Min. Print: [K]	*EGB	Minimum: This is the minimum number of prints after the toner end sensor detects toner end.
3411 002	Min. Print: [C]	*EGB	
3411 003	Max. Print: [K]	*EGB	

3411 004	Max. Print: [C]	*EGB	Maximum: For low image coverage, more sheets can be printed. This sets the maximum that can be printed after toner end is detected. [0 to 750 / 0 / 1/step] DFU
3411 005	Pixel: [K]	*EGB	Adjusts the number of sheets (A4), which the pixel area is converted into for the toner end after detecting the toner near end. [0 to 100 / 0 / 1 sheet/step]
3411 006	Pixel: [C]	*EGB	

3501	[Process Cont.] Process Control		
3501 001	ON/ OFF	*EGB	Sets the method of the process control. [0 to 3 / 0 / 1/step] 0: Auto, 1: Fixed 2: Auto + LS, 3: Auto (Table fixed) Do not use settings 2 and 3.

3511	[Pntr. Display] Process Control Table Display ([Color])		
3511 001	[K]	*EGB	Displays the current process control table for each mode. [1 to 30 / 15 / 1/step]
3511 002	[M]	*EGB	
3511 003	[C]	*EGB	
3511 004	[Y]	*EGB	

3531	[M/A Target] ([Color])		
3531 001	[K]	*EGB	Adjusts the maximum toner target M/A for each mode. [0.000 to 1.000 / 0.53 / 0.001 mg/step]
3531 002	[M]	*EGB	
3531 003	[C]	*EGB	
3531 004	[Y]	*EGB	

3541	[TD Setting] Toner Density Adjustment Setting		
3541 001		*EGB	[0 or 1 / 0 / -] 0: On, 1: Off

3551	[PC SelfChk] Process Control Self-check		
3551 001	Job End 1: [K]	*EGB	At the end of a job, process control is done after the interval of time that is set with SP 3555 001, if this number of pages was printed after the previous process control. [0 to 2000 / 210 / 1 page/step]
3551 002	Job End 1: [C]	*EGB	
3551 003	Job End 2: [K]	*EGB	At the end of a job, process control is done immediately, if this number of pages was printed after the previous process control. [0 to 2000 / 300 / 1 page/step]
3551 004	Job End 2: [C]	*EGB	
3551 005	Job End 3: [K]	*EGB	In the middle of a job, printing stops and

3551 006	Job End 3: [C]	*EGB	process control is done if the number of pages in the job gets to this number. [0 to 2000 / 500 / 1 page/step]
----------	----------------	------	--

3554	[Pow. ON SelfChk] Power On Self-check		
3554 001	Time	*EGB	Adjusts the threshold (Time) of the process control from turning the power on. [0 to 24 / 6.0 / 0.1 H/step]
3554 002	Temp./ Humidity	*EGB	Adjusts the threshold (Temperature/ Humidity) of the process control. [0 to 100 / 6 / 0.1 g/m3/step]
3554 003	Time 2	*EGB	Adjusts the threshold (Time) for developer mixing after turning the power on. [0 to 200.0 / 36.0 / 0.1 H/step]
3554 004	Temp./ Humidity 2	*EGB	Adjusts the threshold (Temperature/ Humidity) for developer mixing after turning the power on. [0 to 100 / 6.0 / 0.1 g/m3/step]

3555	[S.Chk Stand-by] Process Control Self-check Stand-by Time		
3555 001		*EGB	Waiting time for the next job command after job end. If the next job command comes before this interval expires, the "JOB END 1" process control is not done. (SP3551 001 and 002) [0 to 30 / 0 / 1 /sec]

3556	[Image Process.] Display the Time of Last Image Processing		
3556 001	Time (Year)	*EGB	[0 to 99 / 0 / 1 year/step]
3556 002	Time (Month)	*EGB	[1 to 12 / 1 / 1 month/step]
3556 003	Time (Date)	*EGB	[1 to 31 / 1 / 1 day/step]
3556 004	Time (Hour)	*EGB	[0 to 23 / 0 / 1 hour/step]
3556 005	Time (Minute)	*EGB	[0 to 59 / 0 / 1 minute/step]

3557	[Image Process.] Image Processing		
3557 001	Temperature	*EGB	[-127 to 127 / 0.0 / 0.1°C/step]
3557 002	Humidity	*EGB	[0 to 100 / 0 / 0.1% RH/step]
3557 003	A. Humidity	*EGB	[0 to 100 / 0 / 0.1 g/m3/step]/step]

3558	[No Use SelfChk] No Use Self-check		
3558 001	Maximum Repeat	*EGB	Adjusts the maximum repeat times of the process control. [0 to 100 / 10 / 1 time/step]

3561	[Dev g Display] Development gamma Display ([Color])		
3561 001	[K]	*EGB	Displays the development gamma measured

3561 002	[M]	*EGB	during the process control self-check. [0.00 to 5.00 / 0.00 / 0.01/step]
3561 003	[C]	*EGB	
3561 004	[Y]	*EGB	

3562	[Vk Display] ([Color])		
3562 001	[K]	*EGB	Displays the current Vk value. [-300 to 300 / 0 / 1 V/step]
3562 002	[M]	*EGB	
3562 003	[C]	*EGB	
3562 004	[Y]	*EGB	

3573	[Vd Display] ([Color])		
3573 001	[K]	*EGB	Displays the current Vd value. [0 to 1000 / 0 / 1 V/step]
3573 002	[M]	*EGB	
3573 003	[C]	*EGB	
3573 004	[Y]	*EGB	

3574	[VI Display] ([Color])		
3574 001	[K]	*EGB	Displays the current VI value. [0 to 1000 / 0 / 1 V/step]
3574 002	[M]	*EGB	
3574 003	[C]	*EGB	
3574 004	[Y]	*EGB	

3575	[Vb Display] (Process Speed,[Color]) RS: Regular speed, LS: Low speed		
3575 001	RS: [K]	*EGB	Displays the current Vb value for each mode. [0 to 800 / 350 / 1 V/step]
3575 002	RS: [M]	*EGB	
3575 003	RS: [C]	*EGB	
3575 004	RS: [Y]	*EGB	
3575 005	LS: [K]	*EGB	
3575 006	LS: [M]	*EGB	
3575 007	LS: [C]	*EGB	
3575 008	LS: [Y]	*EGB	

3576	[Charge Bias] Charge Roller Bias (DC, Process Speed,[Color]) RS: Regular speed, LS: Low speed		
3576 001	DC: RS: [K]	*EGB	Displays the current charge roller DC bias of the development unit for each mode. [0 to 999 / 585 / 1 V/step]
3576 002	DC: RS: [M]	*EGB	
3576 003	DC: RS: [C]	*EGB	
3576 004	DC: RS: [Y]	*EGB	
3576 005	DC: LS: [K]	*EGB	
3576 006	DC: LS: [M]	*EGB	
3576 007	DC: LS: [C]	*EGB	
3576 008	DC: LS: [Y]	*EGB	

3577	[Charge Bias] Charge Roller Bias (AC, Process Speed,[Color]) RS: Regular speed, LS: Low speed		
3577 001	AC: RS: [K]	*EGB	Displays the current charge roller AC bias of the development unit for each mode. [0.0 to 3.0 / 1.9 / 0.001 kV/step]
3577 002	AC: RS: [M]	*EGB	
3577 003	AC: RS: [C]	*EGB	
3577 004	AC: RS: [Y]	*EGB	
3577 005	AC: LS: [K]	*EGB	
3577 006	AC: LS: [M]	*EGB	
3577 007	AC: LS: [C]	*EGB	
3577 008	AC: LS: [Y]	*EGB	

3581	[LD Control] LD Power Control Displays the current LD power rate for each mode.		
3581 001	LD: RS: [K]	*EGB	[10 to 200 / 100 / 1%/step]
3581 002	LD: RS: [M]	*EGB	
3581 003	LD: RS: [C]	*EGB	
3581 004	LD: RS: [Y]	*EGB	
3581 005	LD: LS: [K]	*EGB	
3581 006	LD: LS: [M]	*EGB	
3581 007	LD: LS: [C]	*EGB	
3581 008	LD: LS: [Y]	*EGB	

3701	[Low Resolution] (Threshold, [Color]) SP 3701-001 controls if the pixel count is used in hybrid toner supply mode or not. If this SP is 'on', it is used if the image coverage ratio for the page is below a threshold value (if the coverage is above this ratio, then the TD sensor is used). If this SP is 'off', then the TD sensor is always used. SP3701-002 to 005 control the threshold values for the image coverage ratio.		
3701 001		*EGB	[0 to 1 / 0 / -] 0: Off, 1: On
3701 002	Threshold: [K]	*EGB	[0 to 100 / 1 / 1%/step]
3701 003	Threshold: [M]	*EGB	
3701 004	Threshold: [C]	*EGB	
3701 005	Threshold: [Y]	*EGB	

3721	[Low Resolution] Toner Refresh Mode Setting in Low Image Coverage Ratio		
3721 001	Toner Refresh Mode		Enables or disables the toner refresh mode. [0 or 1 / 0 / -] 0: On. 1: Off
3721 002	S: Toner Refresh		Toner refresh mode is done if the percentage of pages that have low image coverage is larger than this threshold value. [0 to 50 / 20 / 1%/step]

3801	[TD Initial] TD sensor Initialization ([Color])		DFU
3801 001	[All]		Initializes the developer for each mode.

3801 002	[C]		Press the Enter key to execute the initialization after the machine asks "Execute?"
3801 003	[K]		
3801 004	[M]		
3801 005	[C]		
3801 006	[Y]		

3811	[Developer] Developer Initialization		
3811 001	All		Initializes all the developers.

3820	[Process Cont.] Process Control		
3820 001			Executes the process control. Press the Enter key to execute the initialization after the machine asks "Execute?"

3821	[P Ctl Result] Process Control Result		
3821 001	1	*EGB	Displays each logged process control result. The ten most recent ones are shown. 3821 001 is the most recent. 4.1
3821 002	2	*EGB	
3821 003	3	*EGB	
3821 004	4	*EGB	
3821 005	5	*EGB	
3821 006	6	*EGB	
3821 007	7	*EGB	
3821 008	8	*EGB	
3821 009	9	*EGB	
3821 010	10	*EGB	

SP5-XXX (Mode)

5024		[mm/ inchDisplay]	
5024 001		*CTL	Sets units (mm or inch) for custom paper sizes. [0 or 1 / 1 / -] 0: mm (EU/AS), 1: inch (NA)

5040		[Free Size main] Free Size Main Scan DFU	
5040 001	By-pass	*CTL	Displays the width of the custom paper size that is set by the user. [0.0 to 297.0 / 215.9 / 0.1mm/step]
5040 002	Tray1	*CTL	
5040 003	Tray2	*CTL	
5040 004	Tray3	*CTL	

5041		[Free Size Sub] Free Size Sub Scan DFU	
5041 001	By-pass	*CTL	Displays the length of the custom paper size that is set by the user. [0.0 to 297.0 / 279.4 / 0.1mm/step]
5041 002	Tray1	*CTL	
5041 003	Tray2	*CTL	
5041 004	Tray3	*CTL	

5045		[Accounting count]	
5045 001	Counter Method	*CTL	Selects the counting method if the meter charge mode is enabled with SP5-930-001. You can change the setting only one time. [0 to 1 / 1 / -] 0: Developments, 1: Pages

5051		[Toner Refill Displ] Toner Refill Display	
5051 001		*CTL	Enable or disable the warning display when you install a toner bottle that was refilled by third party vendors. [0 to 1 / 0 / -] 0: Enable, 1: Disable

5150		[Bypass Length Se] By-pass Length Setting	
5801 001		-	Lets or does not let the by-pass tray feed extra long paper (up to 1260 mm). [0 to 1 / 0 / -] Alphanumeric 0: Off, 1: On

5302		[Set Time]	
5302 002	Time difference	*CTL#	Adjusts the RTC (real time clock) time setting for the local time zone. [-1440 to 1440 / NA, EU, CH / 1 minute/step] NA: -300 , EU: 60 , CH: 480

5307 [Summer Time]			
5307 001	Setting	-	Enables or disables the summer time mode. [0 to 1 / 1 / -] Alphanumeric 0: Off, 1: On
5307 003	Rule Set(Start)	-	Specifies the start of the daylight saving time.
5307 004	Rule Set(End)	-	Specifies the end of the daylight saving time.

5404 [UcodeCtrClr] User Code Counter Clear			
5404 001	UcodeCtrClr	-	Clears all counters for users.

5501 [PM Alarm] PM Alarm Level			
5501 001		*CTL	Sets the PM alarm Interval. [0 to 9999 / 0 / 1k prints/step] The alert is sent to the e-mail address that is specified for the system administrator using a browser and the built-in web server (Web Image Monitor). 0: Disables the PM alarm When SP5-866-001 is set to 1, this SP is enabled.

5504 [Jam Alarm]			
5504 001		*CTL	Sets the jam alarm level. If a paper jam occurs, the jam alarm counter increases by +1. If no paper jam occurs while the set number of paper is output, the jam alarm counter decreases by -1. The jam alarm occurs when the jam alarm counter gets to +10. [0 to 3 / 3 / 1/step] 0: Disables the jam alarm 1: 1.5K, 2: 3K, 3: 6K The alert is sent to the e-mail address that is specified for the system administrator using a browser and the built-in web server (Web Image Monitor). When SP5-866-001 is set to 1, this SP is enabled.

5505		[Error Alarm]	
5505 001		*CTL	<p>Sets the error alarm level. If an SC code occurs, the error alarm counter increases by +1. If no SC code occurs while the set number of paper is output, the jam alarm counter decreases by -1. The error alarm occurs when the error alarm counter reaches +5.</p> <p>[0 to 255 / 30 / 1/step] 0: Disables the PM alarm</p> <p>The alert is sent to the e-mail address that is specified for the system administrator using a browser and the built-in web server (Web Image Monitor).</p> <p>When SP5-866-001 is set to 1, this SP is enabled.</p>

5507		[Supply Alarm]	
5507 001	Paper Supply Ala	*CTL	<p>Enables or disables the supply alarm.</p> <p>[0 to 1 / 0 / -] Alphanumeric 0: Off, 1: On</p>
5507 003	Toner Supply Ala	-	
5507 128	Interval: Others	*CTL	<p>Sets the paper supply alarm level. A paper supply alarm counter increases by +1 when a sheet of the related size is used. The paper supply alarm occurs when one of the paper supply alarm counters gets to the set value.</p> <p>[250 to 10000 / 1000 / 1/step]</p> <p>The alert is sent to the e-mail address that is specified for the system administrator using a browser and the built-in web server (Web Image Monitor).</p> <p>When SP5-866-001 is set to 1, this SP is enabled.</p>
5507 133	Interval: A4	*CTL	
5507 134	Interval: A5	*CTL	
5507 142	Interval: B5	*CTL	
5507 164	Interval: LG	*CTL	
5507 166	Interval: LT	*CTL	
5507 172	Interval: HLT	*CTL	

5801		[Memory Clear]	
5801 001	All	-	Resets the SP5801-002 through 016 except the security related data in 003, 010, 011 and 015. These cannot be reset with SP mode.
5801 002	Engine	-	Resets or deletes the engine-related data.
5801 003	SCS	-	Clears the system settings.
5801 004	IMH	-	Clears IMH data. DFU
5801 005	MCS	-	Clears MCS data. DFU
5801 008	PRT	-	Clears the printer application settings.
5801 010	Web Service	*CTL	Clears the web service data and the network application data.
5801 011	NCS	*CTL	Initializes the system default and interface settings (IP address also), SmartNetMonitor for Admin, WebStatusMonitor settings, and the TELNET settings.
5801 014	DCS Setting	*CTL	Resets or deletes the DCS-related data.

5801 015	Clear UCS Setting	*CTL	Resets or deletes the UCS-related data.
5801 016	MIRS Setting		Resets or deletes the MIRS-related data.
5801 017	CCS		Resets or deletes the CSS-related data. FA

5802	[Engine Free Run]		
5802 001			Performs a free run on the printer engine. NOTE: 1) The machine starts free run in the same condition as the sequence of A4/LT printing from the 1st tray. Therefore, paper should be loaded in the 1st tray, but paper is not fed. 2) The main switch has to be turned off and on after using the free run mode for a test.

5803	[Input Check]		
	☛5.2.3		

5804	[Output Check]		
	☛5.2.4		

5807	[Destin. / Model] Destination Code / Model		FA
5807 001	Destination Code	*EGB	[0 to 4 / 0 / 1/step] Alphanumeric 0: DOM (Japan), 1: OTHER, 2: ASIA 3: ERP (Europe). 4: USA
5807 002	Model	*EGB	[0 or 1 / 0 / -] 0: Pla (G104), 1: Plb (G105)

5808	[Destination] Destination Code Display		
5808 001	Destin. Code Disp	*EGB	Displays the destination code. [0 to 4 / 0 / 1/step] Alphanumeric 0: DOM (Japan), 1: OTHER, 2: ASIA 3: ERP (Europe). 4: USA

5810	[Fusing SC Reset]		
5810 001			Resets a type A service call condition. Turn the main power switch off and on after resetting the SC code.

5811	[Serial No.] Machine Serial No. Setting		
5811 001	Setting	*EGB	Sets the machine serial number. FA
5811 002	Display	*EGB	Displays the machine serial number.
5811 003	ID 2 Code Display	*CTL	Displays the ID 2 Code (used for NRS)

5812		[Tel. No. Setting]	
5812 001	Service	*CTL	Sets the telephone number for a service representative. This number is printed on the Counter List, which can be printed with the user's "Counter" menu. This can be up to 20 characters (both numbers and alphabetic characters can be input).
5812 002	FAX TEL No.	*CTL	Sets the fax or telephone number for a service representative. This number is printed on the Counter List, which can be printed with the user's "Counter" menu if the Meter Charge mode is selected with SP5-930-1. This can be up to 13 characters (both numbers and alphabetic characters can be input).

5813		[Power Frequency]	
5813 001		-	Displays the power frequency. [0 to 100 / 0 / 1 Hz/step] Not used

5814		[Power Voltage]	
5814 001	Detected Voltage	-	Displays the detected power voltage. [0 to 400 / 0 / 1 V/step] Not used

5816		[Remote Service] These settings are used for NRS.	
5816 001	I/F Setting	*CTL	[0 to 2 / 2 / 1/step] Alphanumeric 0: Off, 1: CSS (Not used) 2: Network (The remote service function is on.)
5816 002	CE Call	*CTL	[0 to 1 / 1 / 1/step] 0: Start, 1: End
5816 003	Function Flag	*CTL	[0 to 1 / 0 / 1/step] 0: Off (The remote service function is disabled.) 1: On (The remote service function is enabled.)
5816 006	Device Informati	*CTL	Shows or does not show the device information in the User Tools. [0 to 1 / 0 / 1/step] 0: Not displayed, 1: Displayed
5816 007	SSL Disable	*CTL	[0 to 1 / 0 / 1/step] 0: On, 1: Off
5816 008	RCG Connect Time	*CTL	Sets the timeout counter for the remote connection. [1 to 90 / 10 / 1 second/step]
5816 009	RCG Write Timeou	*CTL	Sets the timeout counter for writing processing. [0 to 100 / 60 / 1 second/step]

5816 010	RCG Read Timeout	*CTL	Sets the timeout counter for reading processing. [0 to 100 / 60 / 1 second/step]
5816 011	Port 80 Enable	*CTL	Enables or disables access to the SOAP method via port 80. [0 to 1 / 0 / 1/step] 0: Disables, 1: Enables

5821	[Remote Service Address]		
5821 001	CSS-PI Device Co	*CTL	[0 to 4 / 0 / 1/step] DFU
5821 002	RCG IP Address (used for NRS)	*CTL	Sets the IP address of the RCG (Remote Communication Gate). [00000000h to FFFFFFFFh / 00000000h / 1/step]

5824	[NV-RAM Data Upload]		
5824 001		#	Uploads the UP and SP mode data (except for counters and the serial number) from the NVRAM to an SD card.

5825	[NV-RAM Data Download]		
5825 001		#	Downloads the UP and SP mode data from an SD card to the NVRAM.

5828	[Network] Job spool settings/ Interface selection for Ethernet and wireless LAN		
5828 050	1284 Compatible	*CTL	Switches Centronics IEEE1284 compatibility on/off for the network. [0 or 1 / 1 / -] 0: Disabled, 1: Enabled NOTE: Selecting "0" disables bi-directional data transmission.
5828 052	ECP	*CTL	Switches the ECP setting for Centronics off/on. [0 or 1 / 1 / -] 0: Disabled, 1: Enabled NOTE: With "1" selected, SP5-828-050 must be enabled for 1284 mode compatibility.
5828 065	Job Spool	*CTL	Switches the job spool on/off. [0 or 1 / 0 / -] 0: Disabled, 1: Enabled
5828 066	HD job Clear	*CTL	Selects the treatment of the job when a spooled job exists at power on. [0 to 1 / 1 / 1/step] 0: Data is cleared, 1: Automatically printed

5828 069	Job Spool (Protocol)	*CTL	Switches job spooling off or on and enables settings for job spooling protocols. [0 to 1 / 1 / 1/step] 0: Off, 1: On Bit switch: • Bit 0: LPR • Bit 1: FPT • Bit 2: IPP • Bit 3: SMB • Bit 4: Not used. • Bit 5: DIPRINT • Bits 6 and 7: Reserved
5828 084	Print Settings List	-	Prints a list of NCS related parameters.
5828 085	IP Interface	-	displays the IP interface. [0 to 3 / -] 0: No IP device, 1: DHCP 2: Static IP address 3: DHCP and Static IP address
5828 090	TELNET	*CTL	Enables or disables Telnet. [0 to 1 / 1 / 1/step] 0: Disabled, 1: Enabled
5828 091	Web	*CTL	Enables or disables the Web monitor. [0 to 1 / 1 / 1/step] 0: Disabled, 1: Enabled

5832	[HDD Init.] HDD Initialization		
5832 001		#	Prepares the hard disk. Use this SP mode only when there is a hard disk error.

5839	[IEEE 1394]		
5839 004	Host Name	*CTL	Displays the host name.
5839 007	Cycle Master	*CTL	[0 or 1 / 1 / -] Alphanumeric 0: Off, 1: On
5839 008	BCR mode	*CTL	[0 to 3 / 3 / 1/step] Alphanumeric 0: Standard, 1: IRM Color Copy 2: Reserved, 3: Always Effective
5839 009	IRM 1394a Check	*CTL	[0 or 1 / 0 / -] 0: Off, 1: On
5839 010	Unique ID	*CTL	[0 or 1 / 1 / -] 0: Off, 1: On
5839 011	Logout	*CTL	[0 or 1 / 1 / -] 0: Off, 1: On
5839 012	Login	*CTL	[0 or 1 / 0 / -] 0: Off, 1: On
5839 013	Login MAX	*CTL	[0 to 63 / 8 / 1/step]]

5840		[IEEE 802.11b]	
5840 006	Channel Max	*CTL	Sets the maximum number of channels available for data transmission via the wireless LAN. The number of channels available varies according to location. The default settings are set for the maximum end of the range for each area. Adjust the upper 4 bits to set the maximum number of channels. EU: [1 to 13 / 13 / 1/step] NA/ AS: [1 to 11 / 11 / 1/step]
5840 007	Channel Min	*CTL	Sets the minimum number of channels available for data transmission via the wireless LAN. The number of channels available varies according to location. The default settings are set for the minimum end of the range for each area. Adjust the lower 4 bits to set the minimum number of channels. EU: [1 to 13 / 1 / 1/step] NA/ AS: [1 to 11 / 1 / 1/step]
5840 011	WEP key number	*CTL	Selects the WEP key. [00 to 11 / 00 / 1 binary] 00: Key #1 01: Key #2 (Reserved) 10: Key #3 (Reserved) 11: Key #4 (Reserved)

5842		[NFA analysis] Net File Application Analysis	
5842 001		*CTL	Prints or does not print the module log for each bit. [0 to 1 / 1 / 1/step] 0: Prints, 1: Not print Bit switch: <ul style="list-style-type: none"> • Bit 0: System or other related application. • Bit 1: Captured related application • Bit 2: Certification related application • Bit 3: Address related application • Bit 4: Control devices or transmission logs related application • Bit 5: Output (print, fax or transmission) related application • Bit 6: Documents related application In the Bit 7, 0: Not print, 1: Print <ul style="list-style-type: none"> • Bit 7: MSB related application

5844 [USB]			
5844 001	Transfer Rate	*CTL	Adjusts the USB transfer rate. [0 to 1 / 0 / 1/step] Alphanumeric 0: Auto Change, 1: Full speed
5844 002	Vendor ID	*CTL	Displays the vendor ID.
5844 003	Product ID	*CTL	Displays the product ID.
5844 004	Dev Release Num	*CTL	Displays the device release version number.

5845 [Delivery Srv] Delivery Server			
5845 003	Retry Interval	*CTL	Specifies the retry interval. [60 to 900 / 300 / 1 second/step]
5845 004	No. of Retries	*CTL	Specifies the maximum number of retries. [0 to 99 / 3 / 1/step]

5846 [UCS Setting]			
5846 003	Maximum Entries		Displays the number of maximum entries.
5846 050	Init All Dir	*CTL	Initializes all address information data except the administration account.
5846 098	Bit SW 2	*CTL	FA
5846 099	Bit SW	*CTL	FA

5848 [Web Service]			
5848 004	ac: ud	*CTL	Enables or disables the uirectory access limitation. 0000: Disabled, 0001: Enabled
5848 011	ac: dm	*CTL	Enables or disables the devicemanagement access limitation. 0000: Disabled, 0001: Enabled

5856 [Remote Update]			
5856 002	Local Port		Allows the technician to update the firmware using a parallel cable. [0 to 1 / 0 / 1/step] 0: Disable, 1: Enable

5857 [Save Debug Log]			
5857 001	On/ Off	*CTL	Enables or disables the debug log saving function. [0 to 1 / 0 / 1/step] Alphanumeric 0: On, 1: On
5857 002	Target	*CTL	Sets the storage location for the debug log. [2 to 3 / 2 / 1/step] 2: HDD, 3: SD
5857 005	Save to HDD	*CTL	Sets the key number of the debug log.
5857 006	Save to SD	*CTL	Sets the key number of the debug log.

5857 009	HDD to SD (4MB)	*CTL	Copies the most recent 4 MB of the debug log from the hard disk to the SD card.
5857 010	HDD to SD (Any)	*CTL	Sets the key number of the debug log copied from the hard disk to the SD card.
5857 011	Erase HDD Log	*CTL	Deletes the debug log from the hard disk.
5857 012	Erase SD Log	*CTL	Deletes the debug log from the SD card.
5857 013	Free Space on SD	*CTL	Shows the free space on the SD card.
5857 014	SD to SD (4MB)	*CTL	Copies the most recent 4 MB of the debug log from an SD card to a different SD card.
5857 015	SD to SD (Any)	*CTL	Sets the key number of the debug log copied from an SD card to a different SD card.
5857 016	Make HDD Log File	*CTL	Makes a log file on the HDD to save debug logs. To save debug logs, the controller makes a log file first, then writes data in the file. This procedure can use much time. The user can switch off the main power switch before the log is written in the file. To prevent this possible problem, you can prepare a log file in advance. If you do this, the controller uses less time to save logs because the log file is prepared.
5857 017	Make SD Log File	*CTL	

5858	[Debug Save When]		
5858 001	Engine SC Error	*CTL	Collects debug logs when an engine-related SC code occurs. [0 to 1 / 0 / 1/step] 0: OFF, 1: ON
5858 002	System SC Error	*CTL	Collects debug logs when a controller-related SC code occurs. [0 to 1 / 0 / 1/step] 0: OFF, 1: ON
5858 003	Any SC Error	*CTL	Sets the SC code whose logs are collected. [00000 to 65535 / 0 / 1/step]
5858 004	Jam	*CTL	Collects debug logs when a paper jam occurs. [0 to 1 / 0 / 1/step] 0: OFF, 1: ON

5859	[Log Save Key No.]		
5859 001	Key 1	*CTL	Sets the key number of a specific event (☛ NOTE) whose logs are saved in the specified storage (☛ NOTE). When multiple key numbers are assigned, the logs are collected in this order: Key 1, Key 2, ..., Key 9, Key 10. NOTE: The event is set with SP5-857-2. The storage is set with SP5-858. [0000000 to 9999999 / 0 / 1/step]
5859 002	Key 2	*CTL	
5859 003	Key 3	*CTL	
5859 004	Key 4	*CTL	
5859 005	Key 5	*CTL	
5859 006	Key 6	*CTL	
5859 007	Key 7	*CTL	
5859 008	Key 8	*CTL	
5859 009	Key 9	*CTL	
5859 010	Key 10	*CTL	

5860	[SMTP/ POP3/ IMAP]		
5860 002	SMTP Server Port No.	*CTL	Adjusts the number of the SMTP server ports. [1 to 65535 / 25 / 1/step]
5860 003	SMTP Auth.	*CTL	Enables or disables the SMTP authentication for mail transfers. [0 to 1 / 0 / 1/step] 0: Disable, 1: Enable
5860 006	SMTP Auth. Encryp	*CTL	Encrypts or does not encrypt passwords for POP3/IMAP4 authentications. [0 to 2 / 0 / 1/step] 0: Automatic, 1: Not encrypt, 2: Encrypt
5860 007	POP before SMTP	*CTL	Enables or disables the authentication that is executed on the POP server before the communication is established with the SMTP server to transfer mails. [0 to 1 / 0 / 1/step] 0: Disable, 1: Enable
5860 008	POP to SMTP Wait	*CTL	Adjusts the waiting time to access the SMTP server after the authentication on the POP server. [0 to 10000 / 300 / 1 ms/step]
5860 009	Rev Protocol	*CTL	Sets the protocol of receiving e-mail. [0 to 2 / 0 / 1/step] 0: Not receive, 1: POP3, 2: IMAP4
5860 013	POP Auth. Encryption	*CTL	Encrypts or does not encrypt passwords for POP3/IMAP4 authentications. [0 to 2 / 0 / 1/step] 0: Automatic, 1: Not encrypt, 2: Encrypt
5860 014	POP Server Port No.	*CTL	Adjusts the port number of the POP server. [1 to 65535 / 110 / 1/step]
5860 015	IMAP Srv Port No	*CTL	Adjusts the port number of the IMAP4 server. [1 to 65535 / 143 / 1/step]
5860 017	Receive Interval	*CTL	Adjusts the interval of receiving an e-mail. [2 to 1440 / 3 / 1 minute/step]
5860 019	Mail Keep Sett.	*CTL	Sets the way of keeping the e-mail in the server. [0 to 2 / 0 / 1/step] 0: Not keeping 1: Keeping All 2: Keeping the only error e-mail
5860 020	Part. Mail Rcv Tm	*CTL	Adjusts the time for keeping the partial e-mails. If the partial e-mails are not received during the set time, these are deleted. [1 to 168 / 72 / 1 h/step]
5860 021	MDN Res RFC2298	*CTL	[0 or 1 / 1 / -]
5860 022	SMTP From Replace	*CTL	Determines whether the FROM item of the mail header is switched to the validated account after the SMTP server is validated. [0 to 1 / 0 / 1/step] 0: No. "From" item not switched, 1: Yes. "From" item switched.

5860 025	SMTP Auth Direct	*CTL	<p>Selects directly the way of SMTP authentication if all SMTP authentications fail due to the error in the SP5860-006.</p> <p>This SP is activated only when SP5860-003 is set to "Enable".</p> <p>Bit switch 0: LOGIN Bit switch 1: PLAIN Bit switch 2: CRAM MD5 Bit switch 3: DIGEST MD Bit switch 4 - 7: Not used</p>
----------	------------------	------	---

5866	[E-Mail Alert]		
5866 001	Notice Func E-Ma	*CTL	<p>Enables or disables the alert notice function by e-mail.</p> <p>[0 to 1 / 0 / 1/step] 0: Off, 1: On</p>
5866 005	Add Date Field	*CTL	<p>Enables or disables to add the date field on the alert notice e-mail.</p> <p>[0 to 1 / 0 / 1/step] 0: Off, 1: On</p>

5869	[RAM Disk Setting]		
5869 001	Mail Function	*CTL#	<p>Enables or disables the e-mail transfer function. This SP sets the RAM disk size for the e-mail transfer function.</p> <p>[0 to 1 / 0 / 1/step] 0: On, 1: Off</p>

5870	[Common Key Info W] Common Key Information Writing		
5870 001	Writing		Writes the authentication data (used for NRS) in the memory.
5870 003	Initialize		Initializes the authentication data in the memory.

5873	[SD Card Appli Move]		
5873 1	Move Exec		☛5.4
5873 2	Undo Exec		☛5.4

5907	[Plug/ Play] Plug/ Play Name Selection		
5907 001	*CTL	[0 to 8 / 0 / 1/step]	
		MFG	MDL
		0 RICOH	Aficio CL4000DN
		1 RICOH	Aficio CL4000HDN
		2 SAVIN	CLP26DN
		3 Gestetner	C7425dn
		4 NRG	C7425dn
		5 NRG	C7425hdn
		6 infotec	IPC 2525
		7 infotec	IPC 2525e
		8 LANIER	LP125cx/LP126cn

5930	[Meter Click Ch.] Meter Click Charge		
5930 001		*EGB	Enables or disables the Meter Charge mode. When enabling the Meter Charge mode, the "Counter" menu is added to the user menu. [0 or 1 / 0 / -] Alphanumeric 0: OFF, 1: ON

5950	[Factory Default]		
5950 001		*EGB	Enables the first initial setting. This SP is set to 1 in the factory. This SP is cleared after first turning the main power on. [0 or 1 / 0 / -] FA 0: Disables, 1: Enables

Service Tables

5952	[Under F. Adjust] Under Factory Adjustment		
5952 001		*EGB	[0 or 1 / 0 / -] FA

5953	[dehumidifier] Tray heater Switch Setting		
5953 001		*EGB	Enables or disables the tray heater on/off switch when the main power switch is on. [0 to 1 / 0 / -] Alphanumeric 0: Off, 1: On

5970	[Debug Serial] Debug Serial Port Setting		
		*CTL	DFU

5990	[SP print mode]		
5990 001	All (Data List)		Does SP5-990-002, 004, 005, 006, and 007.
5990 002	SP (Mode Data List)		Prints an SMC report on all SP modes.
5990 004	Logging Data		Prints an SMC report on the SPs that save logs.
5990 005	Diagnostic Report		Prints the Self-Diagnosis Report.
5990 006	Non-Default		Prints an SMC report on the SPs that have settings, which are different from the defaults.
5990 007	NIB Summary		Prints the network configuration report.

SP7-XXX (Data Log)

7002		[Total Counter]	
7002 001	Color Counter	*EGB	Displays the value of the counters. [0 to 9999999 / 0 / 1/sheet]
7002 002	Black Counter	*EGB	

7401		[SC Counter]	
7401 001		*CTL	Displays the number of SC codes detected. [0 to 9999 / 0 / 1/step]

7403		[Latest10SClog]	
7403 001	Latest	*CTL	Logs the SC codes detected. The 10 most recently detected SC Codes are not displayed on the screen, but can be seen on the SMC (logging) outputs.
7403 002	Latest 1	*CTL	
7403 003	Latest 2	*CTL	
7403 004	Latest 3	*CTL	
7403 005	Latest 4	*CTL	
7403 006	Latest 5	*CTL	
7403 007	Latest 6	*CTL	
7403 008	Latest 7	*CTL	
7403 009	Latest 8	*CTL	
7403 010	Latest 9	*CTL	

7502		[Total Jam]	
7502 001		*CTL	Displays the total number of jams detected. [0 to 9999 / 0 / 1 sheet/step]

7504		[Jam Location]	
			Displays the number of jams according to the location where jams were detected.
7504 001	Main 001	*CTL	Not used
7504 003	Main 003	*CTL	Tray 1: ON
7504 004	Main 004	*CTL	Tray 2: ON
7504 005	Main 005	*CTL	Tray 3/LCT: ON
7504 006	Main 006	*CTL	Tray 4: ON
7504 008	Main 008	*CTL	Registration: ON
7504 009	Main 009	*CTL	External Tray: ON
7504 010	Main 010	*CTL	Internal Tray: ON
7504 011	Main 011	*CTL	Duplex: ON
7504 012	Main 012	*CTL	Duplex Exit 1: ON
7504 013	Main 013	*CTL	Duplex Exit 2: ON
7504 015	Main 015	*CTL	Optional paper tray unit feed: ON
7504 061	Main 061	*CTL	Registration: OFF
7504 063	Main 063	*CTL	External Tray: OFF
7504 065	Main 065	*CTL	Duplex: OFF
7504 066	Main 066	*CTL	Duplex Exit 1: OFF
7504 070	Main 070	*CTL	Not used
7504 071	Main 071	*CTL	Not used

7506	[Jam Paper Size]		
7506 133	A4 SEF	*CTL	Displays the number of jams according to the paper size. [0 to 9999 / 0 / 1 sheet/step]
7506 134	A5 SEF	*CTL	
7506 142	B5 SEF	*CTL	
7506 164	LG SEF	*CTL	
7506 166	LT SEF	*CTL	
7506 172	HLT SEF	*CTL	
7506 255	Others	*CTL	

7507	[Jam History]		
7507 001	Latest	*CTL	Displays the 10 most recently detected paper jams.
7507 002	Latest 1	*CTL	
7507 003	Latest 2	*CTL	
7507 004	Latest 3	*CTL	
7507 005	Latest 4	*CTL	
7507 006	Latest 5	*CTL	
7507 007	Latest 6	*CTL	
7507 008	Latest 7	*CTL	
7507 009	Latest 8	*CTL	
7507 010	Latest 9	*CTL	

7803	[PM Counter Disp] Preventive Maintenance Counter Display (Sheets or Rotations (%), Unit, [Color]) Trans Belt Unit: Transfer Belt Unit T. Roll 2: Transfer Roller 2, Waste Toner: Waste Toner Bottles		
Displays the PM counter for each unit.			
7803 001	Paper	*EGB	Displays the number of sheets printed for each current maintenance unit. When a unit is replaced, the machine automatically detects that the new unit is installed. Then, the current PM counter value is automatically moved to the PM Counter - Previous (SP7-906-1 to 10) and is reset to "0". The total number of sheets printed with the last unit replaced can be checked with SP7-906-1 to 10. SP7-803-001: This shows the number of pages printed. [0 to 9999999 / 0 / 1 sheet/step]
7803 002	S: PCU: [K]	*EGB	
7803 003	S: PCU: [M]	*EGB	
7803 004	S: PCU: [C]	*EGB	
7803 005	S: PCU: [Y]	*EGB	
7803 009	S: Transfer Belt Unit	*EGB	
7803 010	S: T. Roll 2	*EGB	
7803 011	S: Fusing Unit	*EGB	
7803 012	S: By-pass	*EGB	
7803 013	S: Tray 1	*EGB	
7803 014	S: Tray 2	*EGB	
7803 015	S: Tray 3	*EGB	

7803 017	R: PCU: [K]	*EGB	Displays the number of revolutions of motors or clutches for each current maintenance unit. [0 to 9999999 / 0 / 1 revolution/step] When a unit is replaced, the machine automatically detects that the new unit is installed. Then, the current PM counter value is automatically moved to the PM Counter - Previous (SP7-906-11 to 20) and is reset to "0". The total number of revolutions made with the last unit replaced can be checked with SP7-906-11 to 20. [0 to 9999999 / 0 / 1 rotation/step]
7803 018	R: PCU: [M]	*EGB	
7803 019	R: PCU: [C]	*EGB	
7803 020	R: PCU: [Y]	*EGB	
7803 025	R: Trans Belt Unit	*EGB	
7803 026	R: T. Roll 2	*EGB	
7803 027	R: Fusing Unit	*EGB	
7803 033	Toner Supply: [K]	*EGB	Displays the number of sheets printed until the waste toner bottle becomes full or toner runs out. [0 to 9999999 / 0 / 1 /step]
7803 034	Toner Supply: [M]	*EGB	
7803 035	Toner Supply: [C]	*EGB	
7803 036	Toner Supply: [Y]	*EGB	
7803 037	R%: PCU: [K]	*EGB	Displays the value given by the following formula: $(\text{Current revolution} \div \text{Target revolution}) \times 100$, where "Current revolution" is the current value for the counter of the part, and "Target revolution" is the values of SP7-803-17 through 27. This shows how much of the unit's expected lifetime has been used up. The R% counter is based on rotations, not prints. If the number of rotations reaches the limit, the machine enters the end condition for that unit. If the print count lifetime is reached first, the machine also enters the end condition, even though the R% counter is still less than 100%. [0 to 999 / 0 / 1 rotation%/step]
7803 038	R%: PCU: [M]	*EGB	
7803 039	R%: PCU: [C]	*EGB	
7803 040	R%: PCU: [Y]	*EGB	
7803 045	R%: Trans Belt Unit	*EGB	
7803 046	R%: T. Roll 2	*EGB	
7803 047	R%: Fusing Unit	*EGB	

7804	[PM Count. Reset] Preventive Maintenance Counter Reset (Sheets, Unit, [Color]) Trans Belt Unit: Transfer Belt Unit, T. Roll 2: Transfer Roller 2, Waste Toner: Waste Toner Bottle, Toner: Toner Bottles		
	Clears the PM counter for each unit.		
7804 002	PCU: [K]	-	Clears the PM counter. Press the Enter key after the machine asks "Execute?". When a unit is replaced, the machine automatically detects that the new unit is installed. Then, the current PM counter value is automatically moved to the PM Counter-Previous (SP7-906-1 to 40) and is reset to "0".
7804 003	PCU: [M]	-	
7804 004	PCU: [C]	-	
7804 005	PCU: [Y]	-	
7804 009	Trans Belt Unit	-	
7804 010	Transfer Roller 2	-	
7804 011	Fusing Unit	-	
7804 012	S: By-pass	-	
7804 013	S: Tray 1	-	
7804 014	S: Tray 2	-	
7804 015	S: Tray 3	-	
7804 017	S: Toner: [K]	-	
7804 018	S: Toner: [M]	-	

7804 019	S: Toner: [C]	-	
7804 020	S: Toner: [Y]	-	
7804 021	Toner Supply: [K]	-	
7804 022	Toner Supply: [M]	-	
7804 023	Toner Supply: [C]	-	
7804 024	Toner Supply: [Y]	-	
7804 050	All		

7806	[Procon Counter] Process Control Counter ([Color])		
7806 001	[K]	*EGB	[0 to 2000 / 0 / 1/step]
7806 002	[C]	*EGB	
	[MUSIC Counter] ([Color])		
7806 003	[K]	*EGB	Counts the paper printed after previous MUSIC. [0 to 999 / 0 / 1/step]
7806 004	[C]	*EGB	
	[P. Pattern Coun.] P. Sensor Pattern Counter ([Color])		
7806 005	[K]	*EGB	[0 to 255 / 0 / 1/step]
7806 006	[C]	*EGB	
	[Low Resolution] Low Resolution Counter ([Color])		
7806 007	Sheets: [K]	*EGB	[0 to 255 / 0 / 1/step]
7806 008	Sheets: [M]	*EGB	
7806 009	Sheets: [C]	*EGB	
7806 010	Sheets: [Y]	*EGB	

7807	[SC/ Jam Clear] SC/ Jam Counter Clear		
7807 001	All Clear	-	Clears the all counters related to SC codes and paper jams.

7810	[Engine Cnt Reset] Engine Counter Reset		
7810 001	All Clear	-	Clears the all Engine counters other than the total counter (SP7812).

7812	[Total Cnt. Rst.] Total Counter Reset		
7812 001	Color Counter	-	Clears the total color counter.
7812 002	Black Counter	-	Clears the total black counter.
7812 100	All Reset	-	Clears the total all counter.

7815	[Rep. Cnter Reset] Replacement Counter Reset (Sheets, Unit, [Color]) Trans Belt Unit: Transfer Belt unit, Waste Toner: Waste Toner Bottle, Toner: Toner Bottle		
7815 001	PCU: [K]	-	Clears the replacement counter and the previous unit counter of the black PCU.
7815 002	PCU: [M]	-	Clears the replacement counter and the previous unit counter of the magenta PCU.
7815 003	PCU: [C]	-	Clears the replacement counter and the previous unit counter of the cyan PCU.

7815 004	PCU: [Y]	-	Clears the replacement counter and the previous unit counter of the yellow PCU.
7815 005	Trans Belt Unit	-	Clears the replacement counter and the previous unit counter of the Transfer belt unit.
7815 006	Transfer Roller 2	-	Clears the replacement counter and the previous unit counter of the Transfer Roller.
7815 007	Fusing Unit	-	Clears the replacement counter and the previous unit counter of the Fusing unit.
7815 008	S: By-pass	-	Clears the replacement counter and the previous unit counter of the Paper pick up roller at by-pass.
7815 009	S: Tray 1	-	Clears the replacement counter and the previous unit counter of the Paper pick up roller at tray 1.
7815 010	S: Tray 2	-	Clears the replacement counter and the previous unit counter of the Paper pick up roller at tray 2.
7815 011	S: Tray 3	-	Clears the replacement counter and the previous unit counter of the Paper pick up roller at tray 3.
7815 029	Toner: [K]	-	Clears the replacement counter and the previous unit counter of the black toner bottle
7815 030	Toner: [M]	-	Clears the replacement counter and the previous unit counter of the magenta toner bottle
7815 031	Toner: [C]	-	Clears the replacement counter and the previous unit counter of the cyan toner bottle
7815 032	Toner: [Y]	-	Clears the replacement counter and the previous unit counter of the yellow toner bottle
7815 100	All	-	Clears the all replacement and the previous unit counters.

7817	[Rep Cnter Reset] Replacement Counter Reset		
7817 001	All Cloear	-	Clears the all adjustment counters.

7832	[Diag. Result] Diagnostic Result		
7832 001		-	Displays the result of the diagnostics. To scroll the return codes, press the up-arrow key or the down-arrow key.

7834	[Cov. Counter] Coverage Counter		
7834 001	All Clear	-	Clears the all coverage counters.

7836	[Total Memory Size]		
7836 001		-	Shows the total storage size.

7853	[Rep. Count. Disp] Replacement Counter Display (Sheets, Unit, [Color]) Trans Belt Unit: Transfer Belt unit, Waste Toner: Waste Toner Bottle, Toner: Toner Bottle		
7853 002	PCU: [K]	*EGB	Displays the replacement counter for each unit. [0 to 9999999 / 0 / 1/step]
7853 003	PCU: [M]	*EGB	
7853 004	PCU: [C]	*EGB	
7853 005	PCU: [Y]	*EGB	
7853 009	Trans Belt Unit	*EGB	
7853 010	Transfer Roller 2	*EGB	
7853 011	Fusing Unit	*EGB	
7853 012	S: By-pass	*EGB	
7853 013	S: Tray 1	*EGB	
7853 014	S: Tray 2	*EGB	
7853 015	S: Tray 3	*EGB	
7853 028	Waste Toner	*EGB	

7901	[Assert Info]		
7901 001	File Name	*CTL	Records the location where a problem is detected in the program. The data stored in this SP is used for problem analysis.
7901 002	# of Lines	*CTL	
7901 003	Location	*CTL	

7906	[PM Counter-PREV] Previous Preventive Maintenance Counter Display (Sheets or Rotation (%),Unit, [Color]) Trans Belt Unit: Transfer Belt Unit, T. Roll 2: Transfer Roller 2, Waste Toner: Waste Toner Bottle, Toner: Toner Bottles			
7906 001	S: PCU: [K]	*EGB	Displays the number of sheets printed with the previous maintenance units. [0 to 9999999 / 0 / 1/step]	
7906 002	S: PCU: [M]	*EGB		
7906 003	S: PCU: [C]	*EGB		
7906 004	S: PCU: [Y]	*EGB		
7906 008	S: Trans Belt Unit	*EGB		
7906 009	S: T. Roll 2	*EGB		
7906 010	S: Fusing Unit	*EGB		
7906 011	R: PCU: [K]	*EGB		Displays the number of revolutions for each unit in the previous maintenance units. [0 to 9999999 / 0 / 1 revolution/step]
7906 012	R: PCU: [M]	*EGB		
7906 013	R: PCU: [C]	*EGB		
7906 014	R: PCU: [Y]	*EGB		
7906 018	R: Trans Belt Unit	*EGB		
7906 019	R: T. Roll 2	*EGB		
7906 020	R: Fusing Unit	*EGB		
7906 026	Toner Supply: [K]	*EGB	Displays the toner supply time for each color in the previous toner bottles. [0 to 9999999 / 0 / 1/step]	
7906 027	Toner Supply: [M]	*EGB		
7906 028	Toner Supply: [C]	*EGB		
7906 029	Toner Supply: [Y]	*EGB		

7906 030	R%: PCU: [K]	*EGB	Displays the value given by the following formula: (Current count ÷ Yield count) x 100, where “Current count” is the current values in the counter for the part, and “Yield count” is the recommended yield. [0 to 999 / 0 / 1 %/step]	
7906 031	R%: PCU: [M]	*EGB		
7906 032	R%: PCU: [C]	*EGB		
7906 033	R%: PCU: [Y]	*EGB		
7906 034	R%: Trans Belt Unit	*EGB		
7906 035	R%: T. Roll 2	*EGB		
7906 036	R%: Fusing Unit	*EGB		
7906 037	S: By-pass	*EGB		Displays the number of sheets fed with the previous maintenance unit. [0 to 9999999 / 0 / 1/step]
7906 038	S: Tray 1	*EGB		
7906 039	S: Tray 2	*EGB		
7906 040	S: Tray 3	*EGB		

7910	[ROM No]		
	Displays the ROM number for each component.		
7910 001	System	7910 160	MSIS
7910 002	Engine	7910 161	MSIS (OPTION)
7910 018	NIB	7910 162	PDF
7910 131	Bluetooth	7910 163	BMLinkS
7910 150	RPCS	7910 180	FONT
7910 151	PS	7910 181	FONT 1
7910 152	RPDL	7910 182	FONT 2
7910 153	R98	7910 183	FONT 3
7910 154	R16	7910 200	Factory
7910 155	RPGL	7910 202	Net File
7910 156	R55	7910 204	Printer
7910 157	RTIFF	7910 209	Test Suite
7910 158	PCL	7910 210	MIB
7910 159	PCLXL	7910 211	WebSystem

7911	[Firmware Ver.] Firmware Version		
	Displays the firmware version.		
7911 001	System	7911 160	MSIS
7911 002	Engine	7911 161	MSIS (OPTION)
7911 018	NIB	7911 162	PDF
7911 131	Bluetooth	7911 163	BMLinkS
7911 150	RPCS	7911 180	FONT
7911 151	PS	7911 181	FONT 1
7911 152	RPDL	7911 182	FONT 2
7911 153	R98	7911 183	FONT 3
7911 154	R16	7911 200	Factory
7911 155	RPGL	7911 202	Net File
7911 156	R55	7911 204	Printer
7911 157	RTIFF	7911 209	Test Suite
7911 158	PCL	7911 210	MIB
7911 159	PCLXL	7911 211	WebSystem

7931	[Toner Info [K]] Toner Bottle Information [K] (R: Replacement or E: End)		
7931 001	Model ID	*EGB	Displays the information number for each category.
7931 002	Cartridge Ver	*EGB	
7931 003	Brand ID	*EGB	
7931 004	Area ID	*EGB	
7931 005	Production ID	*EGB	
7931 006	Color ID	*EGB	
7931 007	Maintenance ID	*EGB	
7931 008	New	*EGB	
7931 009	Recycle Count	*EGB	
7931 010	Prod. Date	*EGB	
7931 011	Serial No.	*EGB	
7931 012	Remaining Toner	*EGB	
7931 013	Toner End	*EGB	Displays the toner end record.
7931 014	Refill Flag	*EGB	Displays the refilling record.
7931 015	R: Total Counter	*EGB	Displays the total number of sheets when replacing the new toner bottle for the b/w mode or the full color mode. [0 to 9999999 / 0 / 1/step]
7931 016	R: Color Counter	*EGB	
7931 017	E: Total Counter	*EGB	Displays the total number of sheets when detecting the toner end for the b/w mode or the full color mode. [0 to 9999999 / 0 / 1/step]
7931 018	E: Color Counter	*EGB	
7931 019	Near End	*EGB	Displays the toner near end record. [0 to 3 / 0 / 1/step]
7931 020	Install Date	*EGB	Displays the date of the install the toner bottle.
7931 021	Toner End Date	*EGB	Displays the date of the toner end.

7932	[Toner Info [M]] Toner Bottle Information [M] (R: Replacement or E: End)		
7932 001	Model ID	*EGB	Displays the information number for each category.
7932 002	Cartridge Ver	*EGB	
7932 003	Brand ID	*EGB	
7932 004	Area ID	*EGB	
7932 005	Production ID	*EGB	
7932 006	Color ID	*EGB	
7932 007	Maintenance ID	*EGB	
7932 008	New	*EGB	
7932 009	Recycle Count	*EGB	
7932 010	Prod. Date	*EGB	
7932 011	Serial No.	*EGB	
7932 012	Remaining Toner	*EGB	
7932 013	Toner End	*EGB	Displays the toner end record.
7932 014	Refill Flag	*EGB	Displays the refilling record.
7932 015	R: Total Counter	*EGB	Displays the total number of sheets when

7932 016	R: Color Counter	*EGB	replacing the new toner bottle for the b/w mode or the full color mode. [0 to 9999999 / 0 / 1/step]
7932 017	E: Total Counter	*EGB	Displays the total number of sheets when detecting the toner end for the b/w mode or the full color mode. [0 to 9999999 / 0 / 1/step]
7932 018	E: Color Counter	*EGB	
7932 019	Near End	*EGB	Displays the toner near end record. [0 to 3 / 0 / 1/step]
7932 020	Install Date	*EGB	Displays the date of the install the toner bottle.
7932 021	Toner End Date	*EGB	Displays the date of the toner end.

7933	[Toner Info [C]] Toner Bottle Information [C] (R: Replacement or E: End)		
7933 001	Model ID	*EGB	Displays the information number for each category.
7933 002	Cartridge Ver	*EGB	
7933 003	Brand ID	*EGB	
7933 004	Area ID	*EGB	
7933 005	Production ID	*EGB	
7933 006	Color ID	*EGB	
7933 007	Maintenance ID	*EGB	
7933 008	New	*EGB	
7933 009	Recycle Count	*EGB	
7933 010	Prod. Date	*EGB	
7933 011	Serial No.	*EGB	
7933 012	Remaining Toner	*EGB	Displays the remaining toner rate. [0 to 100 / 100 / 1%/step]
7933 013	Toner End	*EGB	Displays the toner end record.
7933 014	Refill Flag	*EGB	Displays the refilling record.
7933 015	R: Total Counter	*EGB	Displays the total number of sheets when replacing the new toner bottle for the b/w mode or the full color mode. [0 to 9999999 / 0 / 1/step]
7933 016	R: Color Counter	*EGB	
7933 017	E: Total Counter	*EGB	Displays the total number of sheets when detecting the toner end for the b/w mode or the full color mode. [0 to 9999999 / 0 / 1/step]
7933 018	E: Color Counter	*EGB	
7933 019	Near End	*EGB	Displays the toner near end record. [0 to 3 / 0 / 1/step]
7933 020	Install Date	*EGB	Displays the date of the install the toner bottle.
7933 021	Toner End Date	*EGB	Displays the date of the toner end.

7934	[Toner Info [Y]] Toner Bottle Information [Y] (R: Replacement or E: End times)		
7934 001	Model ID	*EGB	Displays the information number for each category.
7934 002	Cartridge Ver	*EGB	
7934 003	Brand ID	*EGB	

7934 004	Area ID	*EGB	
7934 005	Production ID	*EGB	
7934 006	Color ID	*EGB	
7934 007	Maintenance ID	*EGB	
7934 008	New	*EGB	
7934 009	Recycle Count	*EGB	
7934 010	Prod. Date	*EGB	
7934 011	Serial No.	*EGB	
7934 012	Remaining Toner	*EGB	Displays the remaining toner rate. [0 to 100 / 100 / 1%/step]
7934 013	Toner End	*EGB	Displays the toner end record.
7934 014	Refill Flag	*EGB	Displays the refilling record.
7934 015	R: Total Counter	*EGB	Displays the total number of sheets when replacing the new toner bottle for the b/w mode or the full color mode. [0 to 9999999 / 0 / 1/step]
7934 016	R: Color Counter	*EGB	
7934 017	E: Total Counter	*EGB	Displays the total number of sheets when detecting the toner end for the b/w mode or the full color mode. [0 to 9999999 / 0 / 1/step]
7934 018	E: Color Counter	*EGB	
7934 019	Near End	*EGB	Displays the toner near end record. [0 to 3 / 0 / 1/step]
7934 020	Install Date	*EGB	Displays the date of the install the toner bottle.
7934 021	Toner End Date	*EGB	Displays the date of the toner end.

7935	[PM Interval] Preventive Maintenance Interval (Sheets or Rotations, Unit)		
7935 001	S: PCU	*EGB	Adjusts the interval (the number of sheets) of the PM setting. [0 to 255 / 50 / 1 K/step]
7935 002	R: PCU	*EGB	Adjusts the interval (the rotations) of the PM setting. [0 to 100.00 / 54.26 / 0.01 Km/step]
7935 003	S: Trans. Belt	*EGB	[0 to 255 / 100 / 1 K/step]
7935 004	R: Trans. Belt	*EGB	[0 to 500.00 / 108.52 / 0.01 Km/step]
7935 005	S: Fusing	*EGB	[0 to 255 / 100 / 1 K/step]
7935 006	R: Fusing	*EGB	[0 to 200.00 / 103.79 / 0.01 Km/step]

7936	[PM Count. Reset] Preventive Maintenance Counter Reset	
7936 001	All	Resets the following SP counters. <ul style="list-style-type: none">• SP3251-001 to -004• SP3303-001 to -004• SP3821-001 to -010• SP7931-001 to -021• SP7932-001 to -021• SP7933-001 to -021• SP7934-001 to -021• SP9001-001 to -024• SP9001-029 to -032• SP9001-059 to -061• SP9001-075 to -077• SP9901-001, 002• SP9914-005 to -006

SP8-XXX (Data Log 2)

The counters in Data Log 2 are commonly used in multiple machines. Data Log 2 includes the counters of the functions or units that are not supported by Model G-P1a and P1b. The counters in Data Log 2 are cleared by SP5-801 (Memory Clear) or SP7-808 (Counter Reset).

Keys and abbreviations in Data Log 2

- **Program-related keys and abbreviations**

- T: The grand total of the counters of all application programs
 P: The counter of the printer application program excluding the events related to the document server
 O: The counter of other application programs including remote application programs

8001	[T: 1-0-01]	*CTL	Total jobs
8004	[P: 1-0-01]	*CTL	
The number of times the application program starts a job [0~9999999/ 0 / 1]			

- The jobs interrupted by paper jams or some other errors are also counted.
- The jobs executed by SPs are not counted.

8021	[T: 1-0-03]	*CTL	Print job / Local storage; document server
8024	[P: 1-0-03]	*CTL	
8027	[O: 1-0-03]	*CTL	
The number of times the application program stores data on the document server [0~9999999/ 0 / 1]			

- When images stored on the document server by a network application (including Palm 2), are printed with another application, the O: counter increments.

8031	[T: 1-0-04]	*CTL	Print job/ Designated application program
8034	[P: 1-0-04]	*CTL	
8037	[O: 1-0-04]	*CTL	
The number of times the application program retrieves data from the document server [0~9999999/ 0 / 1]			

- When documents already stored on the document server are printed, the counter of the application program that executes the print job increases.

8061	[T: 1-0-07]	*CTL	Finish, post-print processing jobs
8064	[P: 1-0-07]	*CTL	
8067	[O: 1-0-07]	*CTL	
	The number of times the application program uses the finisher [0~9999999/ 0 / 1]		
001	Sort	The number of times the application program starts the sort mode	
002	Stack	The number of times the application program starts the tack mode	
003	Staple	The number of times the application program starts the staple mode	
004	Booklet	The number of times the application program starts the booklet mode NOTE: The counter of the staple mode (003) can also increase.	
005	Z-Fold	The number of times the application program starts the Z-fold mode NOTE: The booklet mode is not included.	
006	Punch	The number of times the application program starts the punch mode NOTE: The counter of the printer application program (P:) can also increase.	
007	Other	(Reserved)	

8071	[T: 1-0-08]	*CTL	Jobs/ Pages	
8074	[P: 1-0-08]	*CTL		
8077	[O: 1-0-08]	*CTL		
	The number of jobs that try to output a specific number of pages [0~9999999/ 0 / 1]			
-001	1 Page	-008	21~50 Pages	
-002	2 Pages	-009	51~100 Pages	
-003	3 Pages	-010	101~300 Pages	
-004	4 Pages	-011	301~500 Pages	
-005	5 Pages	-012	501~700 Pages	
-006	6~10 Pages	-013	701~1000 Pages	
-007	11~20 Pages	-014	1001~ Pages	

- The jobs interrupted by paper jams or some other errors are also counted.
- If a job is suspended and restarted later, the job is seen as one job.

8381	[T: 2-2-01]	*CTL	Total print pages
8384	[P: 2-2-01]	*CTL	
8387	[O: 2-2-01]	*CTL	
	The number of sheets that the application program tries to print (excluding the pages printed in the SP mode) [0~9999999/ 0 / 1]		

- The following pages are not counted as printed pages:
 - Blank pages in a duplex printing job
 - Blank pages inserted as document covers, chapter title sheets, and slip sheets
 - Reports printed to confirm counts
 - All reports done in the service mode (service summaries, engine maintenance reports, etc.)
 - Test prints for machine image adjustment
 - Error notification reports
 - Partially printed pages as the result of a printer jam

8391	[T: 2-2-02]		
	Large size print pages	*CTL	The number of sheets printed on A3/DLT and larger sizes [0~9999999/ 0 / 1]

8411	[T: 2-2-04]		
	Prints/Duplex	*CTL	The number of sheets used in duplex printing [0~9999999/ 0 / 1]

- The counter increases by +1 when both sides (front/back) are printed. The counter does not increase when one of the two sides is not printed (e.g., the last page of the documents that have three pages, five pages, seven pages, and so on).

8421	[T: 2-2-05]	*CTL	Print pages/ Duplex printing combine
8424	[P: 2-2-05]	*CTL	
8427	[O: 2-2-05]	*CTL	
	The number of sheets used in binding and combining [0~9999999/ 0 / 1]		
001	Simplex> Duplex	*CTL	
004	Simplex Combine	*CTL	
005	Duplex Combine	*CTL	
006	2>	*CTL	2 pages on 1 side (2-Up)
007	4>	*CTL	4 pages on 1 side (4-Up)
008	6>	*CTL	6 pages on 1 side (6-Up)
009	8>	*CTL	8 pages on 1 side (8-Up)
010	9>	*CTL	9 pages on 1 side (9-Up)
011	16>	*CTL	16 pages on 1 side (16-Up)
012	Booklet	*CTL	
013	Magazine	*CTL	

- These counters are useful for the users who want to know how much paper they have saved.
- Partially printed sheets are also counted as 1 page (e.g, the last page in the 4-Up mode is only partially printed when the documents have 5, 6, or 7 pages, 9, 10, or 11 pages, 13, 14, or 15 pages, and so on.).
- Here is a summary of how the counters work in the booklet and magazine modes.

Booklet		Magazine	
Original Pages	Count	Original Pages	Count
1	1	1	1
2	2	2	2
3	2	3	2
4	2	4	2
5	3	5	4
6	4	6	4
7	4	7	4
8	4	8	4

Service Tables

8431	[T: 2-2-06]	*CTL	Print pages/ Image editing performed on the original with the copier GUI
8434	[P: 2-2-06]	*CTL	
8437	[O: 2-2-06]	*CTL	
	The number of pages that the application program handles in a specific way [0~9999999/ 0 / 1]		
001	Cover/Slip Sheet	*CTL	The number of cover sheets or slip sheets inserted NOTE: A duplex-printed cover is counted as two.
002	Series/Book	*CTL	The number of pages printed in series (one side) or in the booklet mode
003	User Stamp	*CTL	The number of pages where stamps were applied (including page numbering and date stamping)

8441	[T: 2-2-07]	*CTL	Print pages/ Paper size
8444	[P: 2-2-07]	*CTL	
8447	[O: 2-2-07]	*CTL	
	The number of sheets of a specific paper size that the application program uses [0~9999999/ 0 / 1]		
001	A3		007 LG
002	A4		008 LT
003	A5		009 HLT
004	B4		010 Full Bleed
005	B5		254 Other (Standard)
006	DLT		255 Other (Custom)

- These counters do not distinguish between LEF and SEF.

8451	[2-2-08]	*CTL	Print pages/ Paper tray
	The number of sheets fed from a specific tray [0~9999999/ 0 / 1]		
8451 001	Bypass Tray	*CTL	By-pass Tray
8451 002	Tray 1	*CTL	Printer
8451 003	Tray 2	*CTL	Paper Tray Unit/LCT (Optional)
8451 004	Tray 3	*CTL	Paper Tray Unit (Optional)
8451 005	Tray 4	*CTL	(Not used)
8451 006	Tray 5	*CTL	(Not used)
8451 007	Tray 6	*CTL	(Not used)
8451 008	Tray 7	*CTL	(Not used)
8451 009	Tray 8	*CTL	(Not used)
8451 010	Tray 9	*CTL	(Not used)

8461	[T: 2-2-09]	*CTL	Print pages/ Paper type
8464	[P: 2-2-09]	*CTL	
	The number of sheets of specific paper types [0~9999999/ 0 / 1]		
001	Normal		005 Normal (Back)
002	Recycled		006 Thick (Back)
003	Special		007 OHP
004	Thick		008 Other

- These counters increase when the paper is output. On the other hand, the PM counter increases (to measure the service life of each feed roller) when the paper is fed.
- Blank sheets (covers, chapter covers, slip sheets) are also counted.
- During duplex printing, a sheet printed on two sides and a sheet printed on one side are both counted as 1.

8471	[2-2-10]	*CTL	Print pages/ Magnification
	The number of pages magnified or reduced [0~9999999/ 0 / 1]		
8471 001	~49%	8471 004	101%~200%
8471 002	50%~99%	8471 005	201% ~
8471 003	100%		

- Some application programs (on the computer) can specify the magnification setting of the printer driver (e.g., MS Excel). In a case like this, SP8-471 recognizes the setting and increases the corresponding counter. Other application programs can magnify or reduce the print images on their own. In a case like this, SP8-471 does not recognize the magnification setting of the application programs and increase the counter of 100%.
- Magnification adjustment conducted on the document server is not counted.
- Blank cover sheets and slip sheets are regarded as 100%.

8481	[T: 2-2-11]	*CTL	Print pages/ Toner save
8484	[P: 2-2-11]	*CTL	
	The number of pages printed with the toner save feature activated [0~9999999/ 0 / 1]		

- These counters display the same result.

8501	[T: 2-2-12]	*CTL	Print pages/ Color mode
8504	[P: 2-2-13]	*CTL	
	The number of pages printed in a specific color mode [0~9999999/ 0 / 1]		
001	B/W	003	Full Color
002	Single Color		

8511	[T: 2-2-14]	*CTL	Print pages/ Emulation
8514	[P: 2-2-14]	*CTL	
	The number of pages printed by the printer emulation mode [0~9999999/ 0 / 1]		
001	RPCS	008	RTIFF
002	RPDL	009	PDF
003	PS3	010	PCL5e/5c
004	R98	011	PCL XL
005	R16	012	IPDL-C
006	GL/GL2	013	BM-Links (for local models only)
007	R55	014	Other

- These counters display the same result.

8521	[T: 2-2-15]	*CTL	Print pages/ Finish post-print processing	
8524	[P: 2-2-15]	*CTL		
	The number of pages processed by the finisher [0~9999999/ 0 / 1]			
001	Sort		005	Z-Fold
002	Stack		006	Punch
003	Staple		007	Other
004	Booklet			

- Even if the pages are too many for the finisher to staple, all pages are counted (including unstapled pages).
- The counter of stapling (003) increases by +1 when the paper is transported from the printer to the tray of the finisher. Even if a paper jam occurs on this path, the counter (003) increases. If the same job is retried, the counter (003) increases once again.

8531	[T: 2-2-16]	*CTL	Staples	
	The number of staples [0~9999999/ 0 / 1]			

8581	[T: 2-2-23]	*CTL	Total counter	
	The number of outputs in a specific color mode [0~9999999/ 0 / 1]			
001	Total		010	Total: Color
002	Total: Full Colo		011	Total: B/W
003	B&W/Single Color		012	Full Colour: A3
004	Development: CMY		013	Full Colour: ~B4
005	Development: K		014	Full Colour Prin
008	Print: Color		015	Mono Colour Prin
009	Print: B/W			

8584	[P: 2-2-23]	*CTL	Print counter	
	The number of outputs in a specific color mode [0~9999999/ 0 / 1]			
8584 001	B/W		8584 003	Full Color
8584 002	Single Color			

8591	[O: 2-2-23]	*CTL	Other counter	
	The number of A3/DLT, duplex printing, or staples [0~9999999/ 0 / 1]			
8591 001	A3/DLT		8591 001	Staple
8591 001	Duplex			

- Note that these counters are not for the printer application program.

8771	[3-0-01]	*CTL	Development counter
	The number of rotations of the development rollers [0~9999999/ 0 / 1]		
8771 001	Total	8771 004	M
8771 002	K	8771 005	C
8771 003	Y		

8781	[TonerBotolInfo] Toner Bottle Information		
8781 001	Last [BK]	*EGB	The number of toner bottles (bottles) already replaced [0~9999999/ 0 / 1]
8781 002	Last [Y]	*EGB	
8781 003	Last [M]	*EGB	
8781 004	Last [C]	*EGB	

8801	[3-0-05]	*CTL	Toner remain
8801 001	K	*CTL	The percentage of the remaining toner [0~100/ 0 / 1]
8801 001	Y	*CTL	
8801 001	M	*CTL	
8801 001	C	*CTL	

8831	[Coverage] Coverage Display (Average, [Color])		
8831 001	Average: [K]	*EGB	The average coverage [0~100/ 0 / 0.01]
8831 002	Average: [Y]	*EGB	
8831 003	Average: [M]	*EGB	
8831 004	Average: [C]	*EGB	

8841	[Coverage] Coverage Display (Last Page, [Color]) L: Last Page		
8841 001	Last: [K]	*EGB	The coverage of the latest print [0~100/ 0 / 0.01]
8841 002	Last: [Y]	*EGB	
8841 003	Last: [M]	*EGB	
8841 004	Last: [C]	*EGB	

- SP8-841 displays the image coverage ratio for each color of the last output. This SP mode displays the coverage ratio of the output, i.e. the ratio of the total pixel area of the image data to the total printable area on the paper. Note that this value is not directly proportional to the amount of toner consumed, although of course it is one factor that affects this amount. The other major factors involved include: the type, total image area and image density of the original, toner concentration and developer potential.

8851	[Coverage: 0-10%] Coverage Display (Sheets, [Color]) S: Sheets		
8851 001	S: [K]	*EGB	[0 to 9999999 / 0 / 1 sheet/step]
8851 002	S: [Y]	*EGB	
8851 003	S: [M]	*EGB	
8851 004	S: [C]	*EGB	

8861	[Coverage: 11-20%] Coverage Display (Sheets, [Color]) S: Sheets		
8871	[Coverage: 21-30%] Coverage Display (Sheets, [Color]) S: Sheets		
8881	[Coverage: 31%-] Coverage Display (Sheets, [Color]) S: Sheets		
001	S: [K]	*EGB	The number of printed sheets of a specific coverage ratio [0~9999999/ 0 / 1]
002	S: [Y]	*EGB	
003	S: [M]	*EGB	
004	S: [C]	*EGB	

- For example, SP8-851-001 displays the number of printed sheets whose black-coverage ratio is 0 percent through 10 percent. SP8-881-004 displays the number of scanned sheets whose cyan-coverage ratio is 31 percent or higher.

8891	[PM Count. Disp] PM Counter Display (Sheets, [Color]) S: Sheets		
8891 001	S: Toner [BK]	*EGB	The number of printed sheets [0~9999999/ 0 / 1]
8891 002	S: Toner [Y]	*EGB	
8891 003	S: Toner [M]	*EGB	
8891 004	S: Toner [C]	*EGB	

8901	[PMCounterPREV1] Previous1 PM Counter Display		
8901 001	S: Toner [BK]	*EGB	The number of printed sheets with the previously replaced units [0~9999999/ 0 / 1]
8901 002	S: Toner [Y]	*EGB	
8901 003	S: Toner [M]	*EGB	
8901 004	S: Toner [C]	*EGB	

8911	[PMCounterPREV2] Previous2 PM Counter Display		
8911 001	S: Toner [BK]	*EGB	The number of printed sheets with the units that was replaced before the previous unit. [0~9999999/ 0 / 1]
8911 002	S: Toner [Y]	*EGB	
8911 003	S: Toner [M]	*EGB	
8911 004	S: Toner [C]	*EGB	

8941	[3-6-01]	*CTL	Machine status
	The amount of time the machine spends in a specific mode [0~9999999/ 0 / 1]		
8941 001	Operation Time	*CTL	The engine is operating. The counter does not include the time when the data is being saved in the HDD (while engine is not operating).
8941 002	Standby Time	*CTL	The engine is not operating. The counter includes the time when the data is being saved in the HDD. The counter does not include the time when the machine is in the Energy Saver Mode, the Low Power Mode, or the Off Mode.
8941 003	Energy Save Time	*CTL	The machine is in the Energy Saver Mode. The counter includes the time when the background printing is being executed.
8941 004	Low Power Time	*CTL	The machine is in the Low Power Mode. The counter includes the time when the engine is on in the Energy Saver Mode. The counter also includes the time when the background printing is being executed.
8941 005	Off Mode Time	*CTL	The machine is in the Off Mode. The counter includes the time when the background printing is being executed. The counter does not include the time when the main power switch is off.
8941 006	Down Time/SC	*CTL	The total downtime caused by SC codes
8941 007	Down Time/PrtJam	*CTL	The total downtime caused by paper jams
8941 008	Down Time/OrgJam	*CTL	The total downtime caused by original jams
8941 009	Down Time/TonEnd	*CTL	The total downtime caused by toner ends

SP9-XXX

9001			
	[Shutter Motor]		
9001 064	Open Time	*EGB	Adjusts the open shutter time. [0 to 990 / 210 / 10 msec/step]
9001 065	Close Time	*EGB	Adjusts the closed shutter time. [0 to 990 / 100 / 10 msec/step]
	[Filming Remov.] Filming Removal (R: Rotation)		
9001 066	R: OPC: Toner	*EGB	[0 to 255 / 1 / 1/step]
9001 067	Toner Dev. Bias	*EGB	[0 to 800 / 50 / 1 V/step]
9001 068	R: OPC: No-Toner	*EGB	[0 to 255 / 30 / 1/step]
	[Filming Remov.] Filming Removal		
9001 069	Filming Coun.: [K]	*EGB	Displays the counter that counts the number of sheets in black and white printing mode from previous filming removal. [0 to 65535 / 0 / 1/step]
9001 074	Interval: [k]	*EGB	Adjusts the threshold for filming removal. This SP is executed even the print job is proceeding. [0 to 65535 / 150 / 1/step]
9001 075	Counter: [FC]	*EGB	Displays the counter that counts the number of sheets in full color printing mode from previous filming removal. [0 to 65535 / 0 / 1/step]
9001 076	Interval: [FC]	*EGB	Adjusts the threshold for filming removal. This SP is executed even the print job is proceeding. [0 to 65535 / 150 / 1/step]
	[Vb: LS] Vb at Low Process Speed		
9001 083	Vb Shift	*EGB	[0 to 65535 / 10 / 1/step]
	[Vc: LS] Vc at Low Process Speed		
9001 084	Vc Shift	*EGB	[0 to 65535 / 0 / 1/step]
	[Filming Remov.] Filming Removal: Job end		
9001 099	Interval (E): [K]	*EGB	Displays the counter that counts the number of sheets in black and white printing mode from previous filming removal. [0 to 65535 / 0 / 1/step]
9001 100	Interval (E): [FC]	*EGB	Displays the counter that counts the number of sheets in full color printing mode from previous filming removal. [0 to 65535 / 0 / 1/step]
9001 101	Interval: [end]	*EGB	Adjusts the threshold for job end filming removal. This SP is not executed until the print job has ended. [0 to 65535 / 75 / 1/step]

9003	[Time Adjust.] Time Adjustment		
	Adjusts the current year, month, date, hour, and minute.		
9003 001	Year	-	[0 to 99 / 0 / 1 y/step]
9003 002	Month	-	[1 to 12 / 1 / 1 m/step]

9003 003	Date	-	[1 to 31 / 1 / 1 d/step]
9003 004	Hour	-	[0 to 23 / 0 / 1 hour/step]
9003 005	Minute	-	[0 to 59 / 0 / 1 m/step]

9801	[DCS Debug] DCS Debug Information		
9801 001	Common	*CTL	DFU
9801 002	IFC	*CTL	
9801 003	SMM	*CTL	
9801 004	SJM/ RJM	*CTL	
9801 005	DSS	*CTL	
9801 006	MRS	*CTL	
9801 007	NAS	*CTL	

9903	[Gamma] Gamma Table (Process Speed, [Color]) RS: Regular Speed, LS: Low Speed		
	Adjusts the gamma table lists for each mode.		
9903 003	RS: [K] 3	*EGB	[0 to 31 / 19 / 1/step]
9903 006	LS: [K] 3	*EGB	[0 to 31 / 12 / 1/step]
9903 009	RS: [M] 3	*EGB	[0 to 31 / 19 / 1/step]
9903 012	LS: [M] 3	*EGB	[0 to 31 / 12 / 1/step]
9903 015	RS: [C] 3	*EGB	[0 to 31 / 19 / 1/step]
9903 018	LS: [C] 3	*EGB	[0 to 31 / 12 / 1/step]
9903 021	RS: [Y] 3	*EGB	[0 to 31 / 19 / 1/step]
9903 024	LS: [Y] 3	*EGB	[0 to 31 / 12 / 1/step]
9903 028	OHP: K3	*EGB	[0 to 31 / 7 / 1/step]
9903 031	OHP: M3	*EGB	[0 to 31 / 7 / 1/step]
9903 034	OHP: C3	*EGB	[0 to 31 / 7 / 1/step]
9903 037	OHP: Y3	*EGB	[0 to 31 / 7 / 1/step]

Service
Tables

9906	[Vpp] (Environment)		
	Adjusts the Vpp value for each environment.		
9906 001	Vpp 1: LL	*EGB	[0 to 3000 / 1950 / 1 V/step]
9906 002	Vpp 2: LL	*EGB	[0 to 3000 / 2200 / 1 V/step]
9906 003	Vpp 1: ML	*EGB	[0 to 3000 / 1780 / 1 V/step]
9906 004	Vpp 2: ML	*EGB	[0 to 3000 / 2030 / 1 V/step]
9906 005	Vpp 1: MM	*EGB	[0 to 3000 / 1770 / 1 V/step]
9906 006	Vpp 2: MM	*EGB	[0 to 3000 / 2020 / 1 V/step]
9906 007	Vpp 1: MH	*EGB	[0 to 3000 / 1810 / 1 V/step]
9906 008	Vpp 2: MH	*EGB	[0 to 3000 / 2060 / 1 V/step]
9906 009	Vpp 1: HH	*EGB	[0 to 3000 / 1770 / 1 V/step]
9906 010	Vpp 2: HH	*EGB	[0 to 3000 / 2020 / 1 V/step]

9908	[Background Po.] Background potential		
9908 001	Upper Limit	*EGB	Adjusts the upper limit vale of background potential. [0 to 300 / 130 / 1/step]
9908 002	Lower Limit	*EGB	Adjusts the lower limit vale of background potential. [0 to 300 / 130 / 1/step]

9910	[Charge Output]		
9910 001	Charge Output	-	Performs the charge output.
	[Toner Fill Up]		
9910 003	[All]	-	Fills up the toner for all colors.
	[TC Initial] Toner Cartridge Initial		
9910 004	[All]	-	Initializes the all toner bottles for each mode.
9910 005	[K]	-	
9910 006	[M]	-	
9910 007	[C]	-	
9910 008	[Y]	-	
	[Toner Fill Up]		
9910 010	[K]	-	Fills up the toner for each color.
9910 011	[M]	-	
9910 012	[C]	-	
9910 013	[Y]	-	
9910 020	Upper Limit	*EGB	Adjusts the upper limit for filling up the toner. If the toner is detected for [N] times, the toner fill up mode ends. [N] can be adjusted with this SP9910-020. [1 to 5 / 3 / 1/step]

9911	[TC Initial] Toner Cartridge Initial		
9911 001	Maximum Repeat	*EGB	[1 to 30 / 15 / 1/step]
9911 002	Threshold	*EGB	[1 to 100 / 20 / 0.01V/step]

9912	[ST Sensor]		
9912 001	read	-	Detects ST sensor output.

9914	[Waste Toner NF] Waste Toner Near Full		
<p>When the waste toner tank full sensor detects 'tank full' for the first time, the operation panel shows that the tank is almost full. Then after 1250 sheets (SP 9914 001), the operation panel shows that the tank is full. After this, if the left or top cover is opened, or if the main power is switched off/on, the machine checks the waste toner tank full sensor. The procedure done by the machine is then as shown below.</p> <p><u>If the sensor detects that the tank is full</u></p> <ol style="list-style-type: none"> 1. The machine can print 250 sheets (SP 9914 002). 2. Then the operation panel again shows that the tank is full. 3. Then if the user opens the cover or turns power off/on again, and the sensor detects 'full', the machine can print 125 sheets (SP 9914 003). 4. Steps 2 and 3 are repeated. <p>If 'not full' is detected at step 3, the machine goes to 'if the sensor detects that the tank is not full' as explained below.</p> <p><u>If the sensor detects that the tank is not full</u></p> <p>The machine can print 2500 sheets (SP 9914 004). If the sensor detects 'full' during this time, the machine starts the detection procedure again (1250 sheets can be printed, and so on, as above). If the sensor always detected 'not full' during this time, then SP 9914 005 and 006 are reset, and the procedure ends.</p> <p>SP 9914 005: The number of times that 'full' was detected. SP 9914 006: The number of prints that were made while the machine was in the 'tank full' condition.</p>			
9914 001	Print 1	*EGB	[0 to 5000 / 1250 / 1/sheet]
9914 002	Print 2	*EGB	[0 to 1000 / 250 / 1/ sheet]
9914 003	Print 3	*EGB	[0 to 1000 / 125 / 1/ sheet]
9914 004	Print 4	*EGB	[0 to 5000 / 2500 / 1/ sheet]
9914 005	Detection Times	*EGB	[0 to 50 / 0 / 1/times]
9914 006	Near Full Count.	*EGB	[0 to 100000 / 0 / 1/ sheet]

9918	[LD Pow. Change] LDB Power Change		
9918 001		*EGB	[0 or 1 / 0 / -] Alphanumeric 0: Not execute, 1: Execute

5.2.3 INPUT CHECK TABLE

When entering the Input Check mode, 8 digits display the result for a section. Each digit corresponds to a different device as shown in the table.

Bit No.	7	6	5	4	3	2	1	0
Result	0 or 1	0 or 1	0 or 1	0 or 1	0 or 1	0 or 1	0 or 1	0 or 1

SP5-803 -XXX	Bit	Description	Reading	
			0	1
001	Input Check 1			
	DFU			
002	Input Check 2			
	0	Color OPC Motor	Locked	Not locked
	1	Black OPC/ Development Motor	Locked	Not locked
	2	Color Development Motor	Locked	Not locked
	3	Paper Feed/ Fusing Motor	Locked	Not locked
	4	Registration Sensor	Paper detected	Paper not detected
	5	Paper Exit Sensor	Paper not detected	Paper detected
	6	Interlock Switch 5V	Open	Close
7	Top Cover Sensor	Close	Open	
003	Input Check 3			
	DFU			
004	Input Check 4			
	0-3	DFU	-	-
	4	Polygon Motor Fan	Locked	Not locked
	5	Color Drum Gear Position Sensor	Activated (Actuator inside sensor)	Deactivated
	6	Black Drum Gear Position Sensor	Activated (Actuator inside sensor)	Deactivated
7	Interlock Switch 24V	Opened	Closed	
005	Input Check 5			
	DFU			
006	Input Check 6			
	DFU			
011	Input Check 11			
	0	Paper Size Sensor 1	Pushed	Not Pushed
	1	Paper Size Sensor 2	Pushed	Not Pushed
	2	Paper Size Sensor 3	Pushed	Not Pushed
	3	Paper Size Sensor 4	Pushed	Not Pushed
	4	Paper Width Sensor	Pushed	Not Pushed
	5	Paper Height Sensor 1	Pushed	Not Pushed
	6	Paper Height Sensor 2	Pushed	Not Pushed
7	Paper End Sensor	Not End	End	

SP5-803 -XXX	Bit	Description	Reading	
			0	1
012	Input Check 12			
	0	Transfer Belt Contact Sensor	Not Contact	Contact
	1	Transfer Roller Contact Sensor	Not Contact	Contact
	2	Duplex Jam Sensor 1	Paper detected	Paper not detected
	3	Duplex Jam Sensor 1	Paper detected	Paper not detected
	4	Fusing New Unit Sensor	New	Old
	5	Fusing Unit Set Sensor P1	Set	Not Set
	6	Fusing Unit Set Sensor P2	Set	Not Set
	7	Not Used	-	-
013	Input Check 13			
	0	Paper Overflow Sensor	Overflow	Not overflow
	1	Fusing Exit Sensor	Paper detected	Paper not detected
	2	Inverter Sensor	Paper detected	Paper not detected
	3	Fusing Unit Fan	Locked	Not locked
	4	PSU Fan	Locked	Not locked
	5	Drive Unit Fan	Locked	Not locked
	6	Paper Exit Fan	Locked	Not locked
	7	DFU		
014	Input Check 14			
	0	Toner End Sensor [Y]	End	Not end
	1	Toner End Sensor [C]	End	Not end
	2	Toner End Sensor [M]	End	Not end
	3	Toner End Sensor [K]	End	Not end
	4	New PCU Detection [Y]	New	Old
	5	New PCU Detection [C]	New	Old
	6	New PCU Detection [M]	New	Old
	7	New PCU Detection [K]	New	Old
015	Input Check 15			
	0	LDU Shutter Sensor	Close	Open
	1	Left Cover Sensor	Close	Open
	2	Waste Toner Overflow Sensor	Not overflow	Overflow
	3	By-pass Paper Detection Sensor	Paper detected	Paper not detected
	4	By-pass Paper Size Sensor 1	Pushed	Not Pushed
	5	By-pass Paper Size Sensor 2	Pushed	Not Pushed
	6	By-pass Paper Size Sensor 3	Pushed	Not Pushed
	7	By-pass Paper Size Sensor 4	Pushed	Not Pushed
016	Input Check 16			
	0-2	Not used	-	-
	3	Fusing Entrance Sensor	Paper detected	Paper not detected
	4	Transfer Belt New Unit Detection	New	Old
	5-7	Not used	-	-
017	Input Check 17			
	0-4	DFU	-	-
	5	Front Door Sensor	Close	Open
	6-7	DFU	-	-

SP5-803 -XXX	Bit	Description	Reading	
			0	1
020	Input Check 20			
	0	Tray 2 Paper Near End Sensor 1	Pushed	Not Pushed
	1	Tray 2 Paper Near End Sensor 2	Pushed	Not Pushed
	2	Tray 2 Paper End Sensor	End	Not end
	3	Tray 2 Paper Feed Sensor	Paper detected	Paper not detected
	4	Tray 2 Paper Size 4	Pushed	Not Pushed
	5	Tray 2 Paper Size 3	Pushed	Not Pushed
	6	Tray 2 Paper Size 2	Pushed	Not Pushed
7	Tray 2 Paper Size 1	Pushed	Not Pushed	
021	Input Check 21			
	0	Tray 3 Paper Near End Sensor 1	Pushed	Not Pushed
	1	Tray 3 Paper Near End Sensor 2	Pushed	Not Pushed
	2	Tray 3 Paper End Sensor	End	Not end
	3	Tray 3 Paper Feed Sensor	Paper detected	Paper not detected
	4	Tray 3 Paper Size 4	Pushed	Not Pushed
	5	Tray 3 Paper Size 3	Pushed	Not Pushed
	6	Tray 3 Paper Size 2	Pushed	Not Pushed
7	Tray 3 Paper Size 1	Pushed	Not Pushed	

5.2.4 OUTPUT CHECK TABLE

5804	[Output Check]	
5804 001	Fusing Fan H	Fusing Unit Fan: High speed
5804 002	Fusing Fan L	Fusing Unit Fan: Low speed
5804 003	PSU Fan	PSU Fan
5804 005	Polygon Fan	Polygon Motor Fan
5804 007	PSU Inner Fan	PSU Inner Fan
5804 008	Drive Fan	Drive Unit Fan
5804 009	Exit Paper Fan H	Paper Exit Fan: High speed
5804 010	Polyg. Mir. Motor	Polygon Mirror Motor
5804 011	Exit Paper Fan L	Paper Exit Fan: Low speed
5804 012	Duplex Fan	Duplex Motor
5804 020	Paper Feed Motor	Paper Feed/ Fusing Motor
5804 022	Mono. PCU Motor	Black OPC/ Development Motor
5804 024	Color PCU Motor	Color OPC Motor
5804 026	Color Dev. Motor	Color Development Motor
5804 030	[Y] Toner Motor	Toner Supply Motor [Y]
5804 031	[C] Toner Motor	Toner Supply Motor [C]
5804 032	[M] Toner Motor	Toner Supply Motor [M]
5804 033	[K] Toner Motor	Toner Supply Motor [K]
5804 034	T. Belt Contact M	Transfer Belt Contact Motor
5804 035	T. Roll 2 Contact M	Transfer Roller Contact Motor
5804 036	LDU Shutter Motor	LDU Shutter Motor
5804 040	Trans. Belt Motor	Transfer Belt Unit Motor
5804 042	Duplex In Motor	Inverter Motor
5804 044	Duplex Exit Motor	Duplex Motor
5804 060	Paper Feed Clutch	Paper Feed Clutch

5804 061	Relay Clutch	Relay Transport Clutch
5804 062	Regist. Clutch	Registration Clutch
5804 063	Develop. Clutch	Development Clutch
5804 064	By-pass Solenoid	By-pass Solenoid
5804 065	Duplex Solenoid	Junction Gate Solenoid
5804 100	[Y]: Charge DC	Charge Roller DC: Yellow PCU
5804 102	[C]: Charge DC	Charge Roller DC: Cyan PCU
5804 104	[M]: Charge DC	Charge Roller DC: Magenta PCU
5804 106	[K]: Charge DC	Charge Roller DC: Black PCU
5804 110	[Y]: Charge AC	Charge Roller AC: Yellow PCU
5804 112	[C]: Charge AC	Charge Roller AC: Cyan PCU
5804 114	[M]: Charge AC	Charge Roller AC: Magenta PCU
5804 116	[K]: Charge AC	Charge Roller AC: Black PCU
5804 118	Charge AC Trigger	Charge Roller AC Trigger
5804 120	[Y]: Develop. DC	Development DC: Yellow
5804 122	[C]: Develop. DC	Development DC: Cyan
5804 124	[M]: Develop. DC	Development DC: Magenta
5804 126	[K]: Develop. DC	Development DC: Black
5804 130	[Y]: Transfer Belt	Transfer Belt Bias: Yellow
5804 132	[C]: Transfer Belt	Transfer Belt Bias: Cyan
5804 134	[M]: Transfer Belt	Transfer Belt Bias: Magenta
5804 136	[K]: Transfer Belt	Transfer Belt Bias: Black
5804 140	T. Roll 2 Posi.	Transfer Roller: Positive Voltage
5804 142	T. Roll 2 Nega.	Transfer Roller: Negative Voltage
5804 200	[Y]: TD. Sensor Vcnt	TD Sensor Vcnt: Yellow
5804 201	[C]: TD. Sensor Vcnt	TD Sensor Vcnt: Cyan
5804 202	[M]: TD. Sensor Vcnt	TD Sensor Vcnt: Magenta
5804 203	[K]: TD. Sensor Vcnt	TD Sensor Vcnt: Black
5804 204	ID. Sensor LED	ID Sensor LED
5804 205	Toner End Sensor	Toner End Sensor
5804 210	ID. Sensor Left	ID. Sensor Left
5804 211	ID. Sensor Center	ID. Sensor Center
5804 212	ID. Sensor Right	ID. Sensor Right
5804 220	Color PCL	Color PCL
5804 221	Mono. PCL	Monochrome PCL
5804 230	PFU 1 Motor	Optional paper tray unit 1 Motor
5804 231	PFU 1 Clutch	Optional paper tray unit 1 Clutch
5804 240	PFU 2 Motor	Optional paper tray unit 2 Motor
5804 241	PFU 2 Clutch	Optional paper tray unit 2 Clutch

5.3 FIRMWARE UPDATE

5.3.1 TYPE OF FIRMWARE

The table lists the programs used by Model G105.

	Type of firmware	Function	Location of firmware	Message displayed
1	Engine - Main	Printer engine control	EGB flash ROM	Engine
2	System	Printer system management	Controller flash ROM	Onboard Sys
3	Printer Application	Feature application	SD card	Opt SD1 Prn
	NIB	NIB management	SD card	Opt SD1 Prn
	Web System	Web service application	SD card	Opt SD1 Prn

5.3.2 PRECAUTIONS

Handling SD Cards

Observe the following precautions when handling SD cards:

- Turn off the main power switch before you insert or remove an SD card. Data in the SD card can be corrupted if you insert or remove an SD card while the main power switch is on.
- Do not turn off the main power switch during downloading.
- Keep SD cards in a safe location. Do not store SD cards in these locations:
 - Locations exposed to high temperature, high humidity, direct sunlight, or strong vibration
 - Locations where there are effects from magnetic forces
- Do not bend or scratch SD cards.
- Do not drop SD cards or expose them to shock or vibration.

NOTE: For the arrangement of files in SD cards, see 5.3.3.

Upload or Download

In this section (5.2.3), “upload” and “download” have these meanings:

- Upload: To copy data from the printer to the SD card
- Download: To copy data from the SD card to the printer

Network Connection

Before you start, tell the user that they cannot use the printer during firmware update, and that they must disconnect the printer physically from the network. If a print job comes in, this can cause problems with the firmware update.

5.3.3 FILE ARRANGEMENT

How the Program Works

The firmware-update program for this machine searches the folder *romdata* for necessary firmware. When you save the firmware in a SD card, make the folder *romdata*. You must not make the folder *romdata* in another folder.

NOTE: Do not make another firmware-update program folder in the folder *romdata*. Otherwise, it may cause a malfunction for the firmware updating. You just keep only one firmware update program folder in the folder *romdata*.

The firmware program contains the file information. Before downloading the firmware from an SD card, the firmware-update program reads the file information. The firmware is downloaded only when the file information is correct.

NOTE: The file information can identify the firmware, but this information does not guarantee that the data is not corrupted.

Example

When you save the firmware, we recommend that you arrange folders and files as follows:

- In the folder *romdata*, make only one folder for one model. Use the machine code as the name of this folder.
- When you save some files other than firmware, make a new folder outside *romdata*. Save the files in this folder. Do not save any file outside the folders. (The diagram shows an example. Three folders, *log*, *nvrdata*, and *prt*, are outside *romdata*. These folders can store debug logs, NVRAM data, and captured files respectively.)

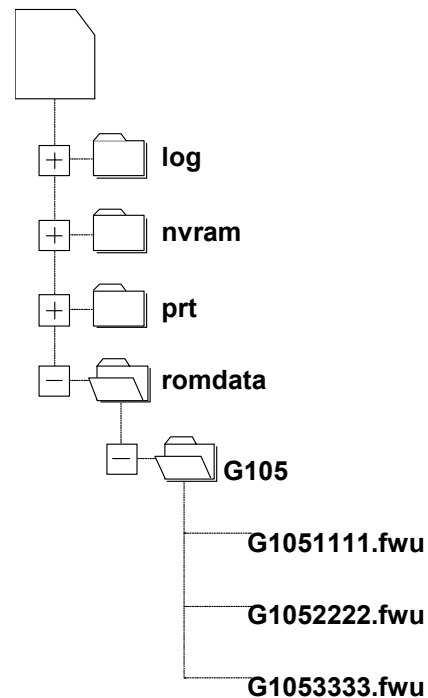

5.3.4 UPDATING

Procedure

1. Turn off the main power switch.
2. Disconnect the printer from the network (☛ 5.3.2).
3. Remove the slot cover from slot 3 (🔧 x 1).

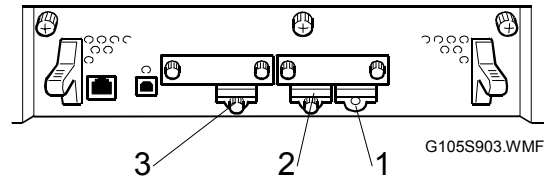

- NOTE:** Do not use the slot 2. The slot 2 is for customer use.
4. Turn the SD card face to the rear side of the printer, and insert it into slot 3.
 5. Slowly push the SD card into the slot until it clicks.
 6. Make sure that the SD card is locked in place.

NOTE: To remove the SD card, push it in until it clicks, and release it slowly. The slot pushes out the SD card.
 7. Turn on the main power switch.
 8. Wait until a firmware name is shown on the display (about 1 minute).

NOTE: The firmware name is read from inside the firmware. The firmware name is not changed even if you change the file name on your PC.
 9. If the necessary firmware name is shown on the display, go to the next step. To use a different firmware, push the up-arrow key or the down-arrow key to find the necessary firmware.
 10. To select the firmware, push the enter key. Make sure that a star (*) is added to the firmware name.
 11. If you update more than one firmware program at the same time, find each of them and select each of them. Make sure a star is added to each firmware name.
 12. To select "Up Date", push the up-arrow key or the down-arrow key.

NOTE: If the customer has used all of three slots, you have to keep an empty slot for this procedure. Ask the customer to temporarily remove one of the SD cards in the slot 2 or 3.

13. To start firmware update, push the enter key. While each firmware is downloaded, the underscores on the operation panel are replaced by stars.
14. Wait until the message "Updated" is shown.
15. Turn off the main power switch.
16. Remove the SD card from the slot.
17. Attach the slot cover (🔑 x 1).
18. Connect the printer to the network physically.
19. Turn on the main power switch.
20. Print the Configuration Page to check that the every firmware is correctly updated: Menu > List/Test Print > Config.P/Er.Log

Error Handling

An error code is shown if an error occurs during the download. Error codes have the letter "E" and a number. If an error occurs, the firmware is not correctly downloaded; see the error code table (5.3.6) and do the necessary steps. After this, download the firmware again.

Power Failure

If firmware update is interrupted by power failure, the firmware is not correctly downloaded. In this condition, machine operation is not guaranteed. You have to download the firmware again.

5.3.5 NVRAM DATA UPLOAD/DOWNLOAD

⚠ CAUTION

Turn off the main power switch before you insert or remove an SD card. Make sure that the controller and the EGB are correctly connected.

Uploading NVRAM Data

Copy the data from the NVRAM to an SD card (referred to as “to upload NVRAM data” in this section) before you replace the NVRAM. If you cannot upload NVRAM data, manually input the necessary settings after you replace the NVRAM.

1. Start the SP mode.
2. Select SP5990-001 (ALL (Data List)).
3. Do the SP.

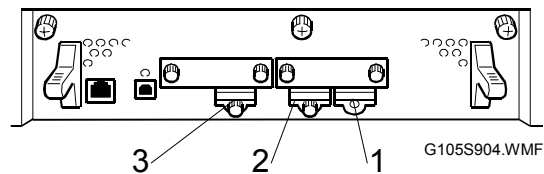

4. See if the SMC Report is correctly output.

NOTE: You may need the SMC Report when the machine did not complete an NVRAM data upload or download (☛ Downloading NVRAM Data) correctly.

5. Go out of the SP mode.
6. Turn off the main power switch.
7. Insert an SD card into slot 3.
8. Turn on the main power switch.
9. Start the SP mode.
10. Select SP5824-001(NVRAM Upload).
11. Push the enter key. The upload starts.
 - When uploading ends correctly, the following file is made:
 - NVRAM\serial_number.NV where “NVRAM” is the folder name in the SD card and “serial_number.NV” is the file name with the extension “.NV”. The serial number of the printer is used as the file name. For example, if the serial number is G1050017, the file name is “G1050017.NV”.
12. Go out of the SP mode.
13. Turn off the main power switch.
14. Remove the SD card.
15. Mark the SD card with, for example, the machine code. You need this SD card when you download NVRAM data (☛ Downloading NVRAM Data).

NOTE: One SD card can store the NVRAM data from two or more machines.

Downloading NVRAM Data

Copy the data from the SD card to the NVRAM (referred to as “to download NVRAM data” in this section) after you replace the NVRAM. If you cannot download NVRAM data, manually input the necessary settings.

1. Make sure that the main power switch is off. If it is on, turn it off.
2. Make sure that you have the correct SD card that contains the necessary NVRAM data.
3. Insert the SD card into slot 3.
4. Turn on the main power switch.
5. Start the SP mode.
6. Select SP5825-001 (NVRAM Download).
7. Push the enter key. The download starts.

NOTE: The machine cannot do the download if the file name in the SD card is different from the serial number of the printer (●Uploading NVRAM Data).

8. Go out of the SP mode.
 9. Turn off the main power switch.
 10. Remove the SD card.
 11. Turn on the main power switch.
 12. Check that the NVRAM data is correctly downloaded.
- This procedure does not download the following data to the NVRAM:

- Total Count
- Serial Number

5.3.6 ERROR CODE TABLE

These error codes are used by more than one model. Some codes are not used by Model G105.

Code	Cause	Solution
20	Cannot map logical address	Make sure SD card inserted correctly, or use another SD card.
21	Cannot access memory	HDD connection incorrect or replace hard disks.
22	Cannot decompress compressed data	Incorrect ROM data on the SD card, or data is corrupted.
23	Error occurred when ROM update program started	Controller program abnormal. If the second attempt fails, replace controller board.
24	SD card access error	Make sure SD card inserted correctly, or use another SD card.
30	No HDD available for stamp data download	HDD connection incorrect or replace hard disks.
31	Data incorrect for continuous download	Insert the SD card with the remaining data required for the download, the re-start the procedure.
32	Data incorrect after download interrupted	Execute the recovery procedure for the intended module download, then repeat the installation procedure.
33	Incorrect SD card version	Incorrect ROM data on the SD card, or data is corrupted.
34	Module mismatch - Correct module is not on the SD card)	SD update data is incorrect. Acquire the correct data (Japan, Overseas, OEM, etc.) then install again.
35	Module mismatch – Module on SD card is not for this machine	SD update data is incorrect. The data on the SD card is for another machine. Acquire correct update data then install again.
36	Cannot write module – Cause other than E34, E35	SD update data is incorrect. The data on the SD card is for another machine. Acquire correct update data then install again.
40	Engine module download failed	Replace the update data for the module on the SD card and try again, or replace the EGB board.
42	Operation panel module download failed	Replace the update data for the module on the SD card and try again, or replace the LCDC.
43	Stamp data module download failed	Replace the update data for the module on the SD card and try again, or replace the hard disks.
44	Controller module download failed	Replace the update data for the module on the SD card and tray again, or replace controller board.
50	Electronic confirmation check failed	SD update data is incorrect. The data on the SD card is for another machine. Acquire correct update data then install again.

5.4 SD CARD APPLI MOVE

5.4.1 OVERVIEW

The service program “SD Card Appli Move” (SP5873) enables you to copy application programs from an SD card to another SD card.

There are two SD card slots. Model G105 can use slot 3 to store application programs. Slot 3 is for maintenance work. Because of this, if the application programs are stored in two SD cards or more, ① choose one SD card from these SD cards and ② store all the application programs on one card.

Use extreme caution when using SD Card Appli Move:

1. The authentication data is transferred with the application program from an SD card to the other SD card. Authentication fails if you try to use the SD card after you copy the application program from this card to another SD card.
2. Do not use an SD card if it has been used for some other work, for example, on a computer. Normal operation is not guaranteed when such SD card is used.
3. Keep the SD card in the place (●Note) after you copy the application program from the card to another card. This is because: ① The SD card can be the only proof that the user is licensed to use the application program. ② You may need to check the SD card and its data to solve a problem in the future.
NOTE: Refer to “Keeping the SD card” in the end of this chapter.

5.4.2 MOVE EXEC

The menu “Move Exec” (SP5873-001) enables you to copy application programs from the original SD card to another SD card. The application programs are copied as follows:

- From slot 3 to slot 2 when SD cards are in slots 2 or in all slots

Note that the authentication data is also copied with the application program (➡ 5.4.1).

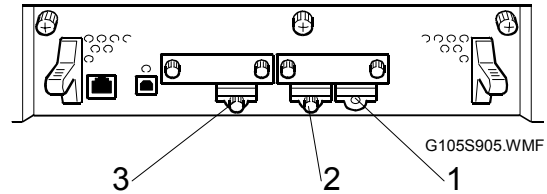

1. Turn off the main power switch.
2. Make sure that an SD card is in slot 2. The application program is copied to SD card in slot 2.
3. Insert the SD card (having stored the application program) to slot 3. The application program is copied from this SD card.
4. Turn on the main power switch.
5. Start the SP mode.
6. Select SP5873-001 “Move Exec.”
7. Follow the messages displayed on the operation panel.
8. Go out of the SP mode.
9. Turn off the main power switch.
10. Remove the SD card from slot 3.
11. Turn on the main power switch.
12. Check that the application programs run normally.

5.4.3 UNDO EXEC

The menu “Undo Exec” (SP5873-002) enables you to copy back application programs from an SD card to the original SD card. You can use this program when, for example, you have mistakenly copied some programs by using Move Exec (SP5873-001). The application programs are copied as follows:

- From slot 2 to slot 3 when SD cards are in slots 2 or in all slots

Note that the authentication data is also copied with the application program (☞ 5.4.1).

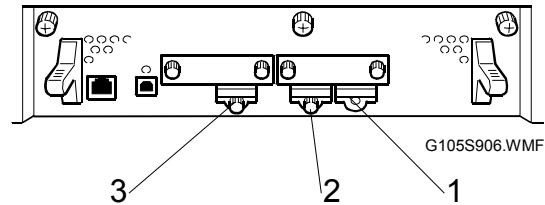

1. Turn off the main power switch.
2. Insert the original SD card in slot 3. The application program is copied back to this card.
3. Make sure that the SD card (having stored the application program) is in slot 2. The application program is copied back from this SD card.
4. Turn on the main power switch.
5. Start the SP mode.
6. Select SP5873-002 “Undo Exec.”
7. Follow the messages displayed on the operation panel.
8. Go out of the SP mode.
9. Turn off the main power switch.
10. Remove the SD card from slot 3.
11. Turn on the main power switch.
12. Check that the application programs run normally.

Keeping the SD card

After moving exe, the original SD card must be kept. Keep the SD card in the place [A] as drawing shows and fasten it with a tape.

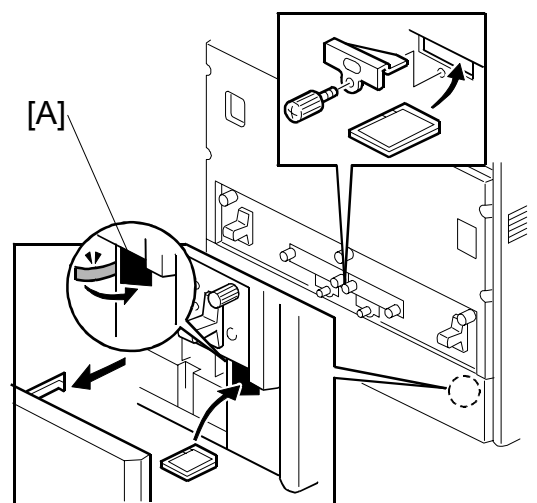

5.5 CONTROLLER SELF-DIAGNOSTICS

There are two types of self-diagnostics for the controller.

- Power-on self-diagnostics: The machine automatically starts the self-diagnostics just after the power has been turned on.
- SC detection: The machine automatically detects SC conditions at power-on or during operation.

The following shows the workflow of the power-on self-diagnostics.

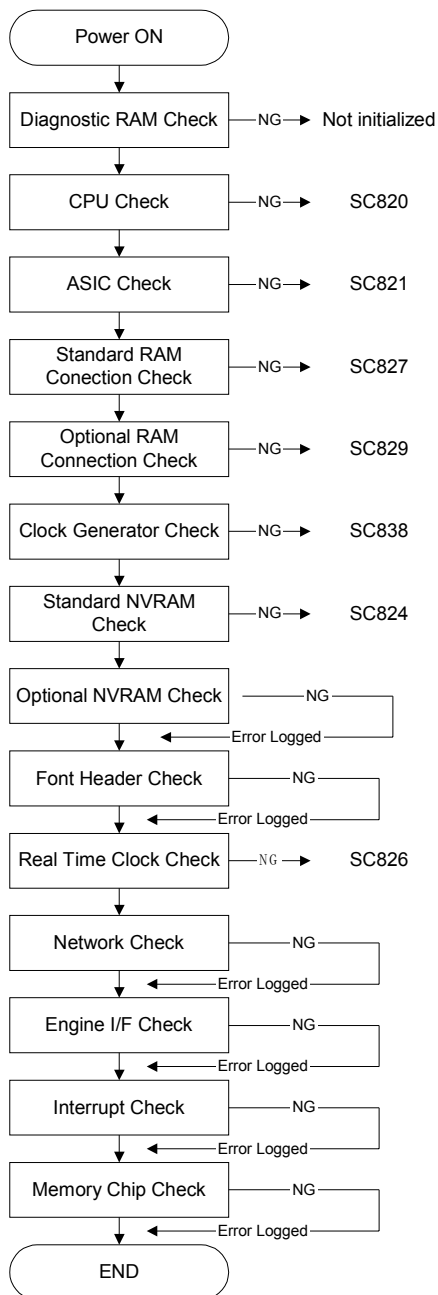

6. DETAILED SECTION DESCRIPTIONS

6.1 OVERVIEW

6.1.1 COMPONENT LAYOUT

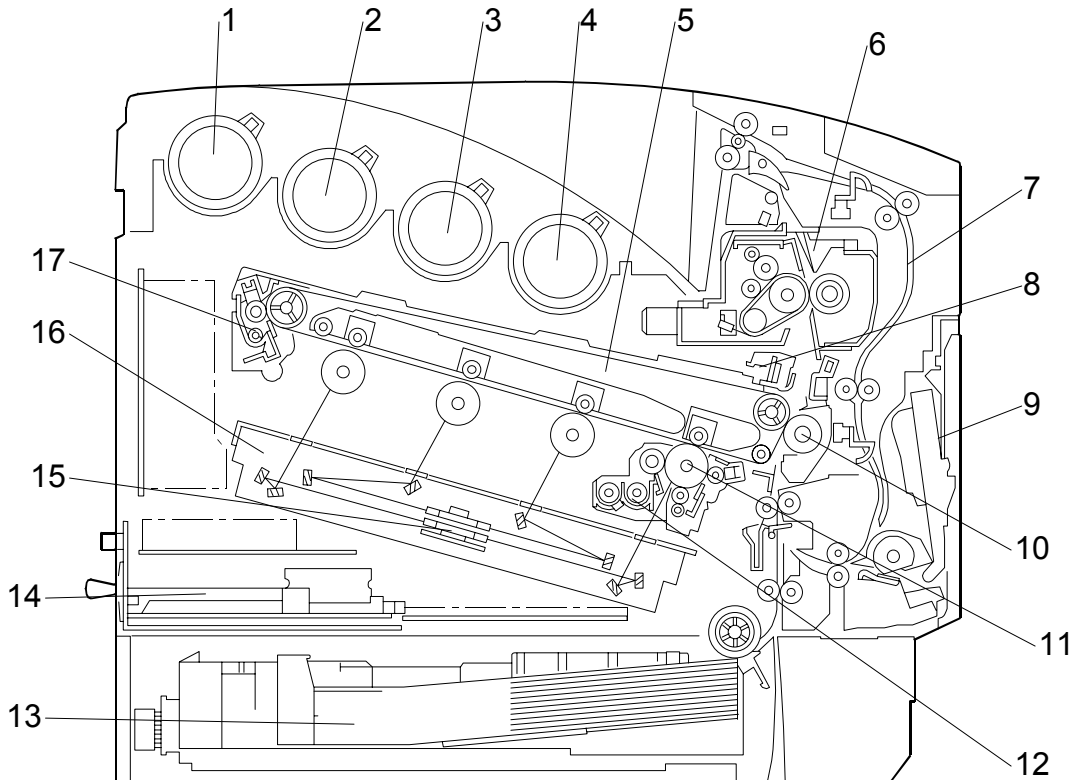

G105V101.WMF

- | | |
|-----------------------|---------------------------------|
| 1. Toner bottle [Y] | 10. Transfer roller |
| 2. Toner bottle [C] | 11. PCU (Photo Conductor Unit) |
| 3. Toner bottle [M] | 12. Development Unit |
| 4. Toner bottle [K] | 13. Standard tray |
| 5. Transfer Belt Unit | 14. PSU (Power Supply Unit) |
| 6. Fusing Unit | 15. Polygon Mirror Motor |
| 7. Duplex Unit | 16. LDU |
| 8. ID sensor | 17. Transfer Belt Cleaning Unit |
| 9. By-pass Feed Table | |

6.1.2 PAPER PATH

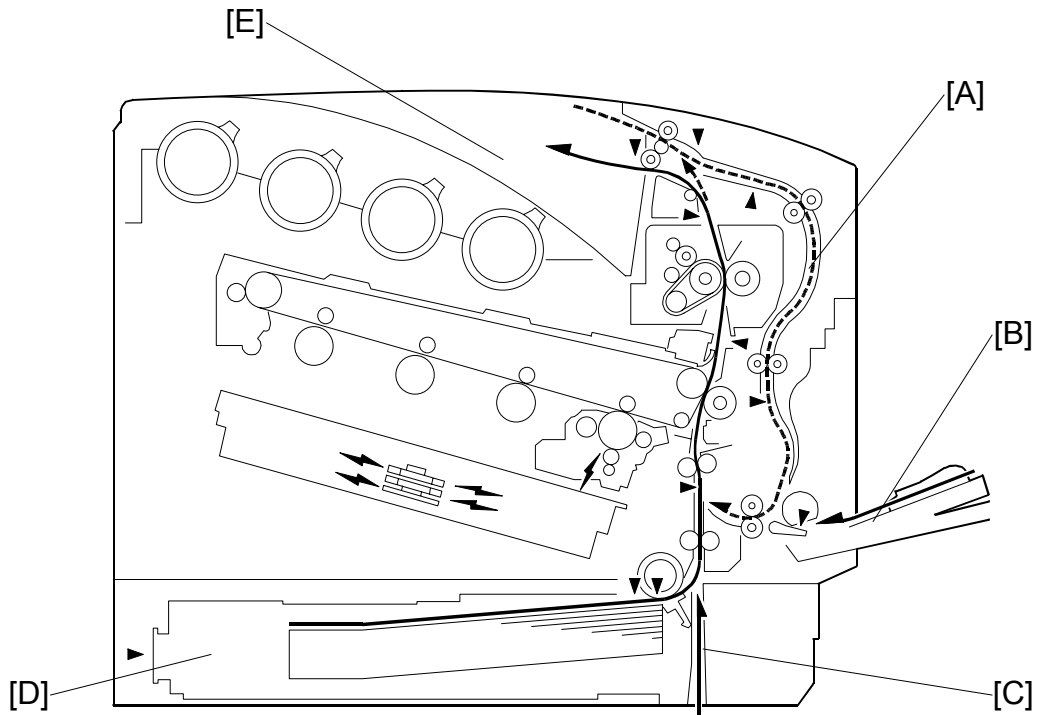

G105V102.WMF

- [A]: By-pass Feed Table
- [B]: Standard tray
- [C]: Optional 1 Tray Paper Feed Unit, 2 Tray Paper Feed Unit
- [D]: Duplex Unit
- [E]: Standard Paper Exit Tray (Internal Tray)



6.1.3 DRIVE LAYOUT

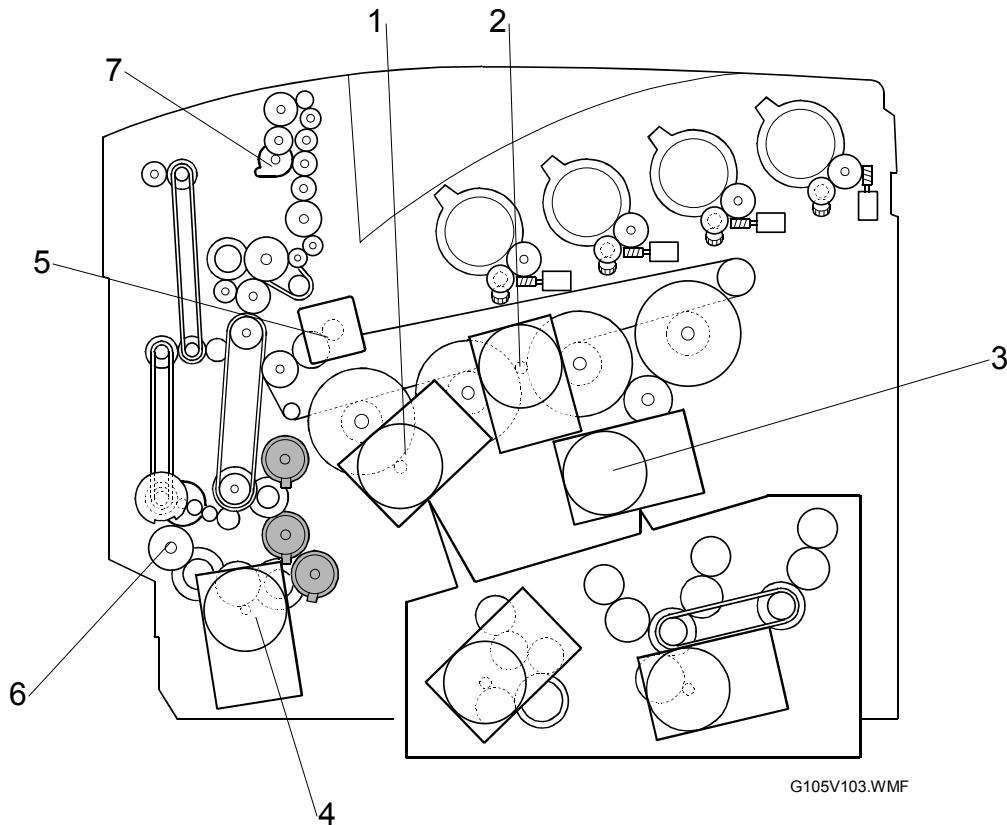

1. **Black OPC/ Development Motor:**
This controls the black OPC and development unit for black.
2. **Color OPC Motor:**
This controls the OPCs for magenta, cyan, and yellow.
3. **Color Development Motor:**
This controls the color development units (magenta/cyan/yellow).
4. **Paper Feed/ Fusing Motor:**
This controls the paper feed mechanisms (tray 1/by-pass tray), fusing unit, paper, registration roller, transport relay roller and paper exit roller.
5. **Transfer Belt Unit Motor:**
This controls the transfer belt unit and the transfer roller.
6. **Duplex Motor:**
This controls the duplex exit, relay and exit rollers.
7. **Inverter Motor:**
This controls the inverter roller.

6.1.4 BOARD STRUCTURE

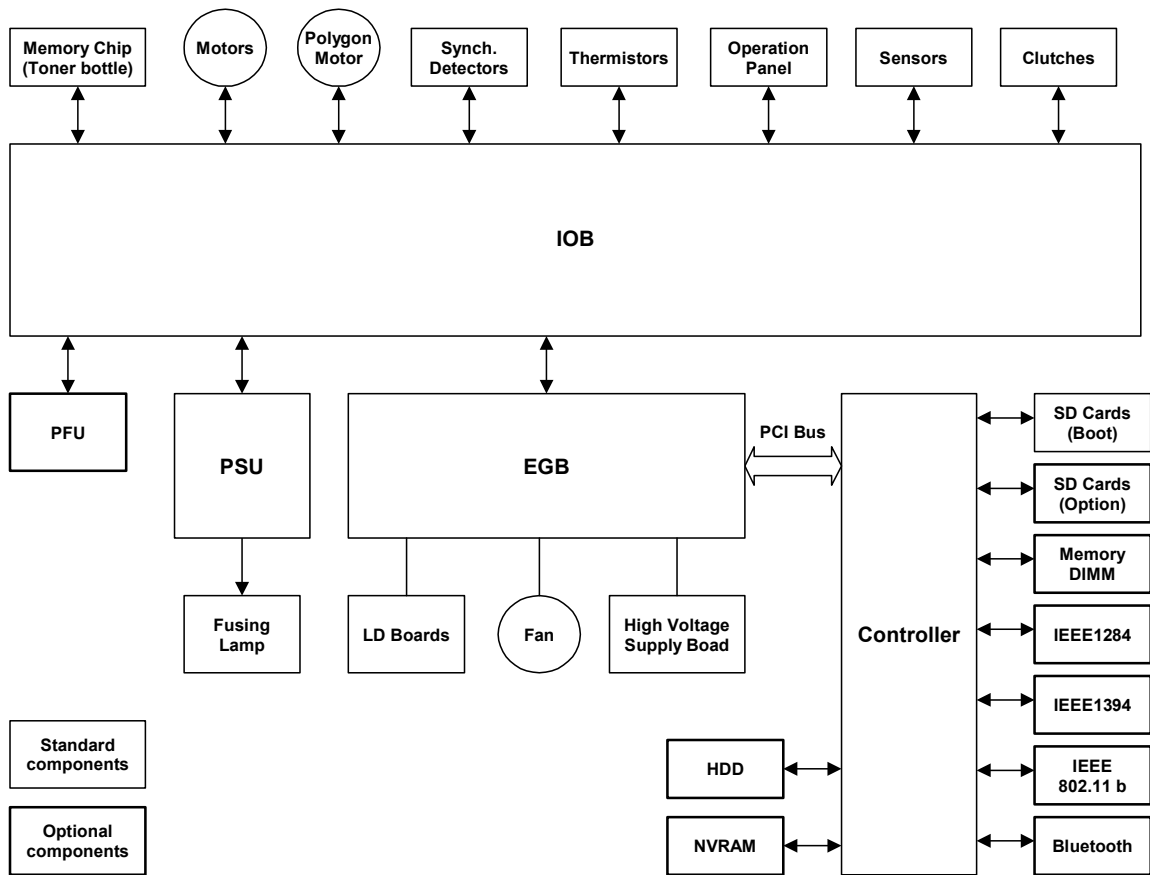

G105D902.WMF

The EGB (Engine Board) controls all of the machine and the handshake with the CTL (Controller). The IOB (In/Out Board) controls input/output, drivers and input/output -connections. The IOB is a part of the EGB expansion board.

Only two of the optional interface boards (IEEE1284, IEEE1394, IEEE802.11b, and Bluetooth) can be installed.

The controller connects to the EGB through the PCI Bus (Peripheral Component Interconnect Bus).

Descriptions

1. **EGB (Engine Board):**
This controls the Engine, the controller interface, image processing, MUSIC (Mirror Unit for Skew and Interval Correction), and input/output. MUSIC is also called Automatic Line Position Adjustment).
2. **IOB (Input/Output Board):**
This controls input/output, and the interfaces with the optional units, and the operation panel.
3. **Controller:**
The controller board controls these functions:
 - SD cards (Boot)
 - SD cards (Option)
 - Memory DIMM
 - IEEE1284
 - IEEE1394
 - IEEE802.11b
 - Bluetooth
 - NVRAM
 - HDD
4. **LD Drive Board:**
This is the laser diode drive circuit board.
5. **IEEE1394 Interface (Option):**
This lets computers connect to this printer with an IEEE1394 interface.
6. **HDD Unit (Option):**
The HDD unit stores the data for these items.
 - Additional software fonts
 - Collation
 - Locked print
 - Sample print
 - Downloaded forms for form overlay
7. **Memory DIMM (Standard: 64MB DRAM, Option: 64/128/256MB DRAM):**
This is for more printer processing memory, and is also used for collation and for soft fonts.
8. **Operation Panel Board:**
Controls the display panel, the LED, and the keypad.
9. **IEEE1284 Interface (Option):**
This is a parallel printer port.
10. **USB:**
Lets you connect the printer to a computer.
11. **Bluetooth (Option):**
Lets you connect the printer to a computer with a wireless connection.
12. **IEEE802.11b wireless LAN (Option):**
Lets you connect the printer to a computer with a wireless connection.

6.1.5 PRINTING PROCESS

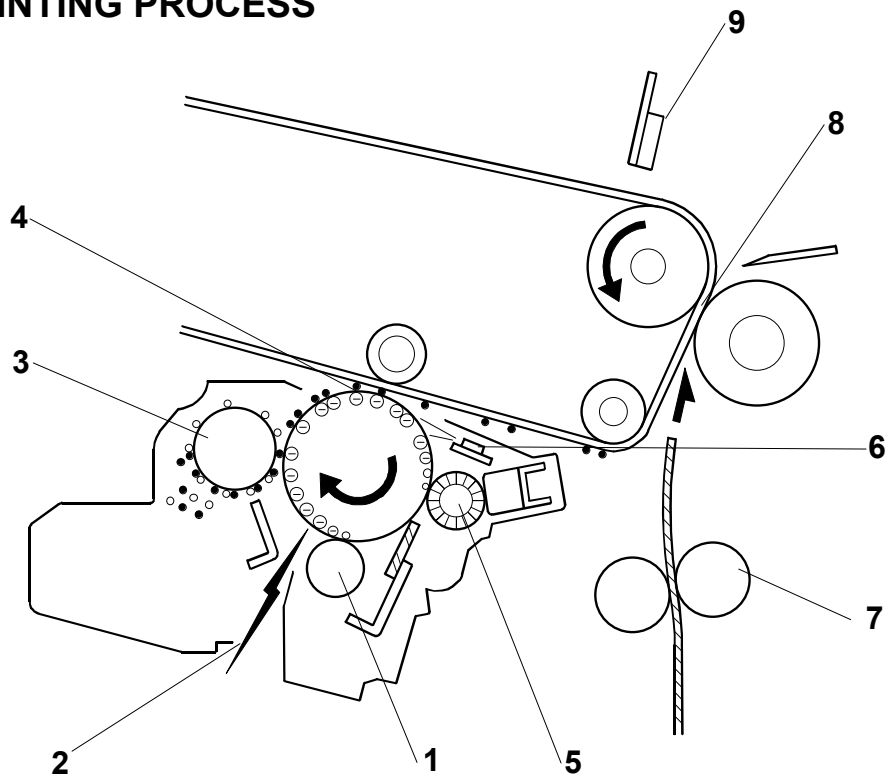

G105D101.WMF

This machine uses four PCUs, four development units, and four laser beams for color printing. Each PCU contains a drum, charge roller, cleaning brush, and blade.

The toner image on each drum is moved to the transfer belt. The four colors are put on the belt. All four toners are put on the belt at the same time. Then the completed four-color image is moved to the paper.

1. **Drum charge:**
The charge roller gives the drum a negative charge
2. **Laser exposure:**
The laser beam from the laser diode (LD) goes through the lens and mirrors and to the drum. To make a latent image on the drum, the machine turns the laser beam on and off.
3. **Development:**
The development roller moves negatively-charged toner to the latent image on the drum surface. This machine uses four development units (one for each color).
4. **Image transfer:**
The charge that is applied to the transfer roller pulls the toner from the drum to the transfer belt. Four toner images are put on the paper.
5. **Cleaning for OPC drum:**
The cleaning brush and blade remove remaining toner on the drum surface after image transfer to the paper.
-  6. **Quenching for OPC drum:**
Quenching is done at the end of each page with a quenching lamp (LED array) in the PCU.
7. **Paper registration:**
The registration roller controls the paper feed timing to make sure that the image transfers to the correct location on the paper. It also removes skew.
8. **Paper Transfer and Separation:**
Toner transfers from the transfer belt to the paper when the paper is fed between the transfer belt and transfer roller. At this time, the paper also separates from the transfer belt, because of a discharge plate immediately after the transfer roller.
9. **ID sensor:**
The ID sensor board contains three ID sensors (one at the left, one at the center, and one at the right). The ID sensor detects the density of the ID sensor pattern on the transfer belt. The ID sensor output is used for process control and for automatic line-position adjustment, skew, and color registration adjustments for the latent image.

6.2 PROCESS CONTROL

6.2.1 OVERVIEW

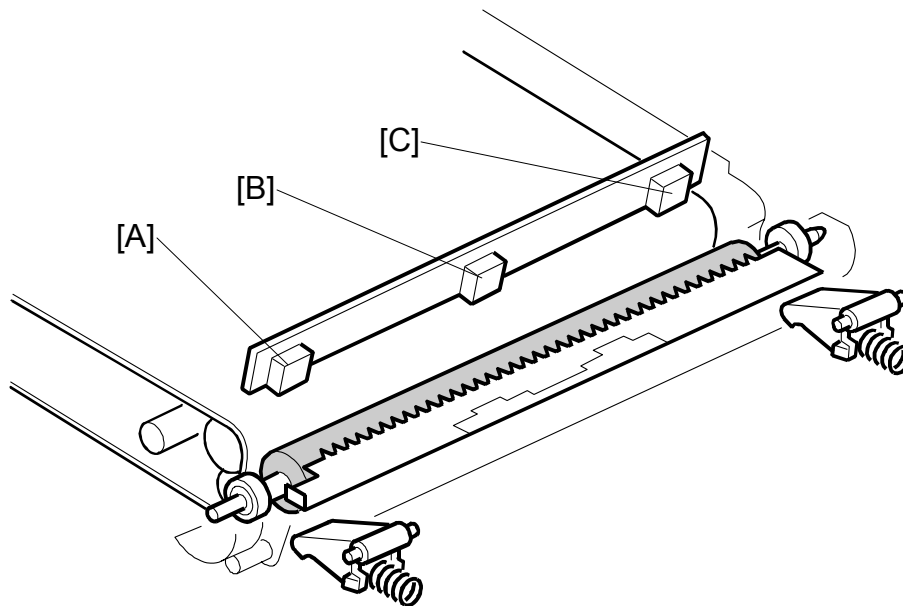

G105D117.WMF

This machine has these two forms of process control:

- Potential control
- Toner supply control

Process control uses these components:

- Three ID (image density) sensors (left [A], center [B], and right [C]). Only the center ID sensor is used for process control. The left, center, and right ID sensors are used for line positioning and other adjustments.
- TD (toner density) sensor in each development unit.

6.2.2 POTENTIAL CONTROL

Overview

Potential control controls development to keep the toner images on the drums at the same density. It does this by compensating for variations in drum chargeability and toner density.

The machine uses the ID sensor to measure the reflectivity of the transfer belt and the density of a standard sensor pattern. This is done during the process control self-check.

The machine measures these values from the ID sensor output and a reference table in memory.

- VD: Drum potential without exposure – to adjust this, the machine adjusts the charge roller voltage.
- VB: Development bias
- VL: Drum potential at the strongest exposure – to adjust this, the machine adjusts the laser power.

(Also, VREF is corrected. This is used for toner supply control.)

This controls the development potential to make sure that the maximum quantity of toner applied to the drum is constant.

If SP3-501-001 is set to 1 (Fixed), the machine does not do the potential control, but uses these parameters:

- Development bias adjusted with SP2-212-001 to –008
- Charge roller voltage adjusted with SP2-201-001 to –009
- Laser power selected with SP2105-001 to –012.
- However, these SPs are not normally adjusted in the field.

Process Control Self-check

This machine does potential control with a procedure that is known as the process control self-check. This procedure is done at these 9 times.

1. Initial

This starts automatically at these times:

- Immediately after the power is turned on
- When the machine comes back from energy saver mode
- 6 hours after the power was turned on (can be changed with SP 3554 001)
- If absolute humidity changes more than $\pm 6 \text{ g/m}^3$ (e.g. $23^\circ\text{C}/50\% \rightarrow 27^\circ\text{C}/70\%$). The humidity threshold can be changed with SP 3554 002.

2. Interval: Job End

At the end of a job, process control is done after the interval of time that is set with SP 3555 001, if more than 210 prints were made after the previous process control (this number can be changed with SP3551-001 and -002).

At the end of a job, process control is done immediately, if more than 300 prints were made after the previous process control (this number can be changed with SP3551-003 and -004).

The default setting of SP 3555 001 is 0. Because of this, there is no difference between these two processes, and the 300-print setting is not used.

After process control is done (except for forced process control), the counters are reset to "0."

3. Interval: Interrupt (default: 500)

If the machine makes a sequence of 500 or more color prints in the same job, printing stops and process control is done. After it is completed, the machine continues to make prints. The default value of 500 can be adjusted with SP3551-005 to -006

4. Non-use Time (6 hours)

This starts before the next print job if the machine has no job for 6 hours. If the non-use time process control is done (N) times after the user turns on the power, it will not be done. N is adjusted with SP3558.

5. Installation

This starts only when this machine turns on at first installation. The machine does this if SP5-950-001 is set to 1 (set in the factory).

6. After Toner End Recovery

This starts after recovery from a toner end condition.

7. After Developer Initialization

This starts after a developer initialization is done. Developer initialization occurs automatically after a new PCU is installed.

8. After Transfer Belt Unit Initialization

This starts after a transfer belt unit initialization is done. Transfer belt unit initialization occurs automatically after a new transfer belt unit is installed.

9. Forced

This is done when SP3-820-001 is used.

6.2.3 PROCESS CONTROL SELF-CHECK PROCEDURE

Step 1: VSG Adjustment

This machine uses three ID sensors (direct-reflection type). They are located at the left, center, and right of the transfer unit. Only the center ID sensor is used for process control. The ID sensor checks the bare transfer belt's reflectivity and the machine calibrates the ID sensor until its output (known as VSG) is as follows.

- VSG = 4.0 ± 0.5 Volts

This calibration adjusts for the transfer belt's condition and the ID sensor condition, for example, dirt on the belt or ID sensor.

Step 2: ID Sensor Solid Pattern Generation

The machine mixes the developer and then makes a 10-gradation pattern on the transfer belt for each toner color. The pattern has 10 squares (the sequence is as follows: 10 black squares, 10 magenta squares, 10 cyan squares and 10 yellow squares). Each of the squares is 15.03 mm x 12.23 mm, and is a solid-color square. To make the squares, the machine changes the development bias and charge roller voltage. The difference between development bias and charge roller voltage is always the same.

Step 3: Sensor Pattern Detection

The ID sensor detects the densities of the 10 solid-color squares for each color. This data goes to memory.

Step 4: Toner Amount Calculation

The quantity of toner on the transfer belt (M/A, mass per unit area, mg/cm^2) is calculated for each of the 10 gradations of the sensor pattern. To do this, the machine uses the ID sensor output value from each gradation of the pattern.

Step 5: V_D , V_B , V_L Selection and V_{REF} Adjustment

The machine makes a plot of the 10 values of M/A against the development potential that was used to make each of the gradations. Then it makes a line through the 10 points.

Then, it finds the development potential that is necessary to put the 'target M/A' of toner on the OPC.

This development potential is then used to find the best values of development bias, charge roller voltage and laser power for the machine in its current condition. To do this, it refers to a table in memory.

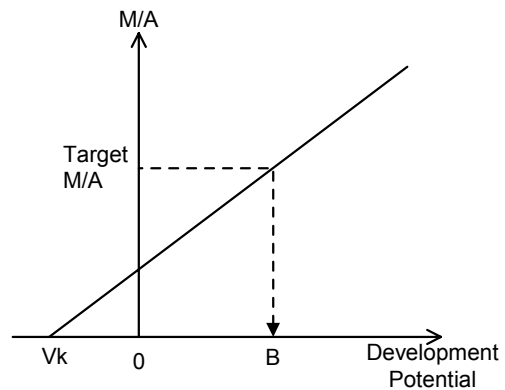

G105D947.WMF

The machine also adjusts V_{REF} (toner density target) at the same time. As a result, the development gamma detected by process control will be the value stored in SP3-561-001 to -004 (do not adjust in the field unless told to do this).

After that, the transfer belt cleaning unit cleans the transfer belt.

6.2.4 TONER SUPPLY CONTROL

Toner Supply Control Modes

This machine has four toner supply control modes. They are selected with SP 3-301-001 to -004.

1. Fixed supply mode
This mode is used when the TD sensor becomes defective. The amount of toner supply can be adjusted with SP3-302-001 -004 if the image density is incorrect (the default setting is 5%).
2. Proportional control mode 1 (Pixel)
This mode is used when the TD sensor becomes defective. Only the pixel count is used to control toner supply. The amount of toner supply can be adjusted with SP3-306-001 to -004.
3. Proportional control mode 2 (TD sensor)
This mode is used when the ID sensor at the center becomes defective. Only the TD sensor is used to control toner supply. The amount of toner supply can be adjusted with SP3-306-005 to -008.

4. Hybrid control mode

This is the default toner supply control mode. The TD sensor or the pixel count are used in this mode.

- If the image coverage ratio is less than the value of SP 3-701-002 to 005, pixel count is used.
- If the image coverage ratio is more than the value of SP 3-701-002 to 005, the TD sensor is used.
- But, if SP 3-701-001 is 'off', then the TD sensor is always used. The default setting for this SP is 'off'. Because of this, pixel count is not used.

The amount of toner supply can be adjusted with SP3-306-009 to -020.

The TD sensor is in the PCU. If the TD sensor becomes defective, the technician must replace the PCU. But if this is not possible, the technician can change the toner supply mode with SP 3-301-001 to 004.

Low Image Coverage

After process control, toner refresh mode is done (this can be switched off with SP 3721 001).

- It is only done if the percentage of pages (after the previous process control) that had low image coverage is more than the value of SP 3721 002.
- SP 3701 002 to 005 control the limits that the machine uses to detect if the image coverage is low.

Toner refresh mode supplies new toner, because there is old toner in the developer after printing many pages that have low image coverage.

During toner refresh mode, the machine does these things:

- 1) The machine mixes the developer for 5 seconds.
- 2) It does an engine free run, which simulates printing of 10 sheets of A4 size paper with the image data (2 by 2) and normal toner supply.
- 3) It mixes the developer for 10 seconds.

6.2.5 TONER NEAR END/TONER END DETECTION

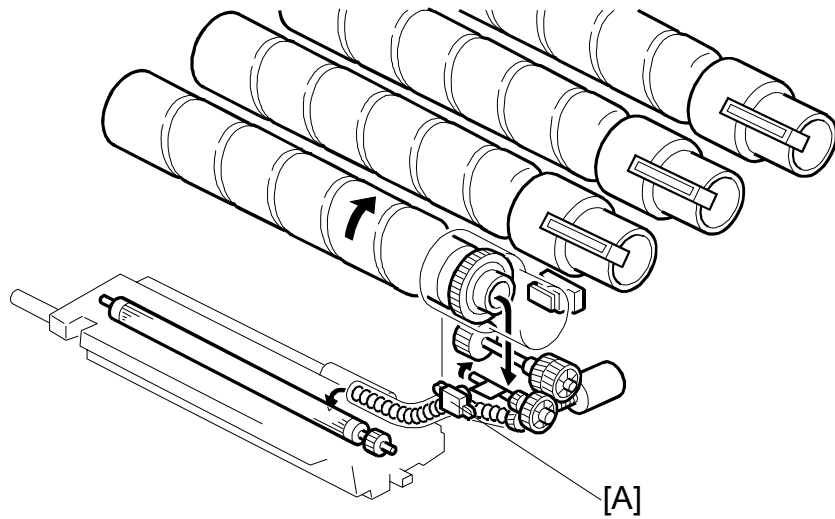

G105D106.WMF

Introduction

Toner Near End

To detect toner near-end the machine uses:

- Pixel count (memory chip on the toner bottle)

Toner End

To detect toner end the machine uses:

- Output from the toner end sensor [A]

Toner Near End Detection

The machine uses the pixel count.

- 1) The controller counts the printed pixels. Then, it calculates the remaining toner quantity from the record in the ID chip for each toner bottle.
- 2) If the remaining toner quantity is less than 10% of a full bottle, the machine detects toner near-end.
- 3) The remaining toner quantity and “Toner near end” are recorded in the ID chip.
- 4) Toner near-end is displayed.

NOTE: Toner near-end detection uses the pixel counter in the ID chip. If new toner is added to the empty toner bottle, the contents of the ID chip are not reset, so the toner near-end or end condition is not reset. Also, near-end detection cannot be done.

Toner End Detection

The machine detects toner end when the toner end sensor detects toner end 3 times in a row 3.1 seconds after toner was supplied. At this time, “Toner end” is recorded in the ID chip.

Toner End Recovery

The machine detects that the toner bottle was replaced if one of these events occurs during a toner end condition:

- The top cover is opened and closed.
 - The main switch is turned off and on.
- 1) The machine then starts to supply toner to the development unit. After this, the machine resets the toner end condition.

NOTE: 1) When “Toner near end” is detected, “Toner end recovery” is not done.
2) If there is no “Toner end” information in the ID chip, the machine detects that there is toner in the toner bottle and “Toner end recovery” is done.

6.2.6 DEVELOPER INITIALIZATION

When the machine detects that a new PCU was installed, it initializes the developer.

To do this, the machine mixes the developer for a few seconds, and adjusts VCNT (control voltage for TD sensor) to make VT (TD sensor output) equal to 2.5 ± 0.1 volts. The machine stores this VT as VREF.

During PCU initialization, the machine automatically supplies toner because there is no toner in the toner supply pipe at installation. Then the machine does the process control self-check.

6.3 PAPER FEED

6.3.1 OVERVIEW

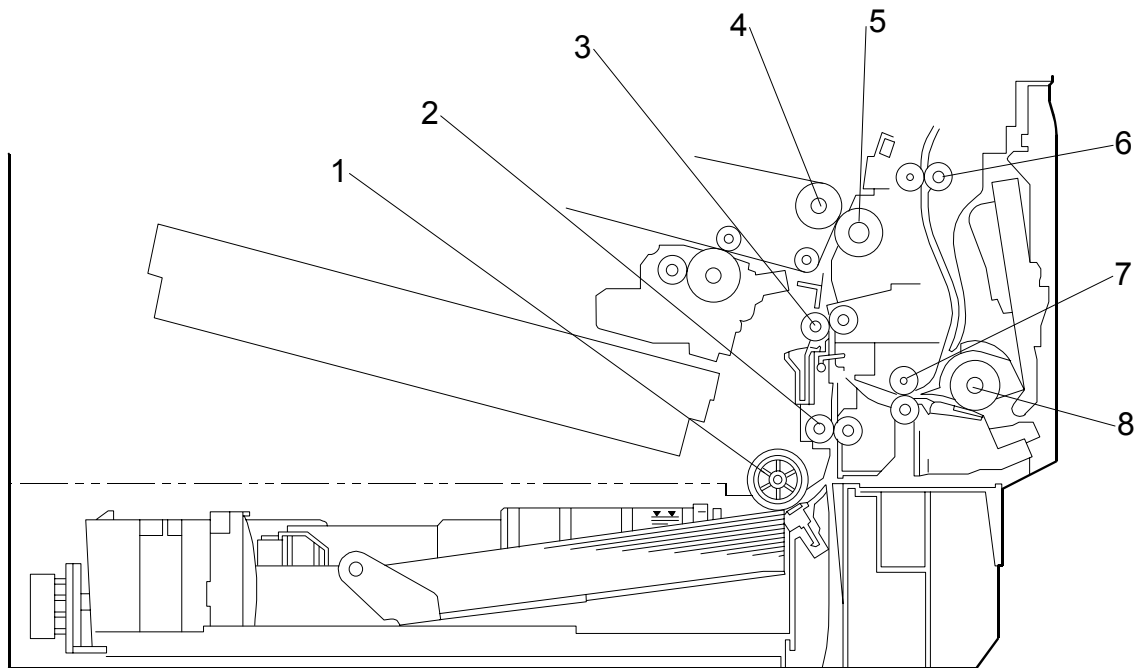

G105D126.WMF

- | | |
|-------------------------------|------------------------|
| 1. Paper feed roller | 5. Transfer roller |
| 2. Relay transport roller | 6. Duplex relay roller |
| 3. Registration roller | 7. Duplex exit roller |
| 4. Transfer belt drive roller | 8. By-pass feed roller |

The machine has a paper tray (550 sheets) and a by-pass paper feed table (100 sheets).

The paper feed mechanism uses a friction pad system.

6.3.2 PAPER FEED DRIVE

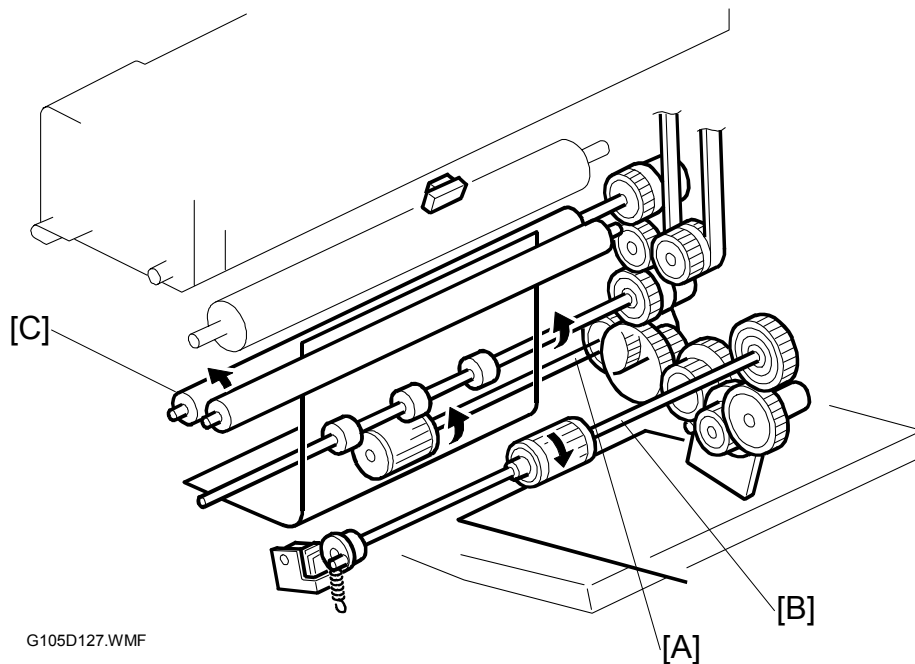

The paper feed and fusing motor controls the paper feed roller [A], by-pass feed roller [B] and registration roller [C] with clutches and gears. The paper feed roller and by-pass feed roller feed a sheet of paper to the registration roller.

The machine makes a paper buckle at the registration roller to correct paper skew. The paper buckle can be adjusted with SP1-003-001 to -045.

6.3.3 PAPER TRAY

Paper Lift

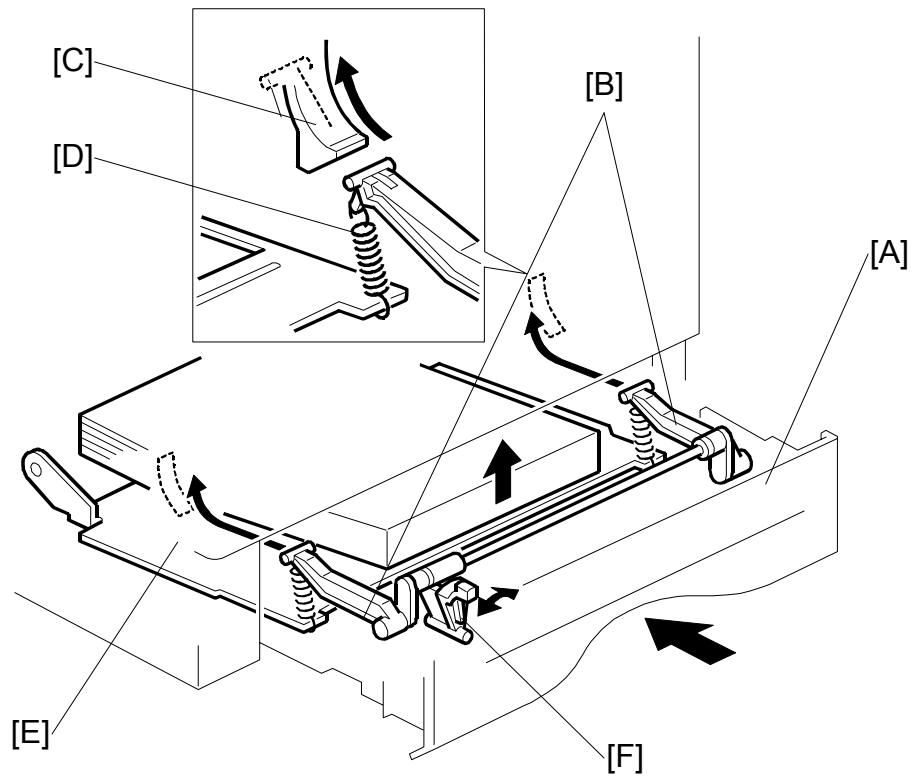

G105D128.WMF

When the tray [A] is put in the machine, the tray arms [B] move along the guide slopes [C] of the main frame. This makes the springs [D] lift the bottom plate. The bottom plate [E] pushes the paper against the paper feed roller and keeps the top sheet of paper at the correct height.

The paper pressure switch [F] adjusts the bottom plate pressure. When you use thick paper of 75g/m² or more, move this switch to the left.

Paper Size Detection

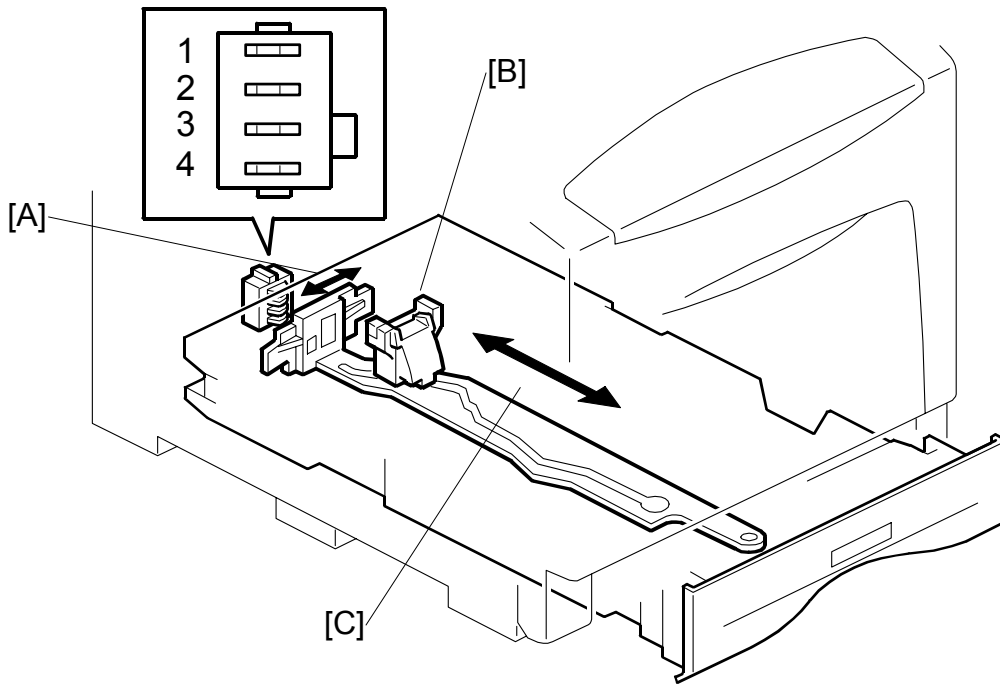

G105D129.WMF

The paper size sensor is at the rear of the tray. This sensor has four switches. The outputs from the switches detect the paper size, as shown in the table. The actuators are on the side plate [A]. The side plate is moved by the end plate [B] through a cam [C].

Paper Size	Switch Location			
	1	2	3	4
LG SEF	Pushed	Pushed	-	-
A4 SEF	-	Pushed	Pushed	-
LT SEF	Pushed	Pushed	Pushed	Pushed
US. EXE SEF	Pushed	-	-	-
B5 SEF	Pushed	-	-	-
A5 SEF/ HLT SEF	-	Pushed	Pushed	Pushed
A5 LEF/ HLT LEF	-	-	Pushed	Pushed

Paper Near End/End Detection

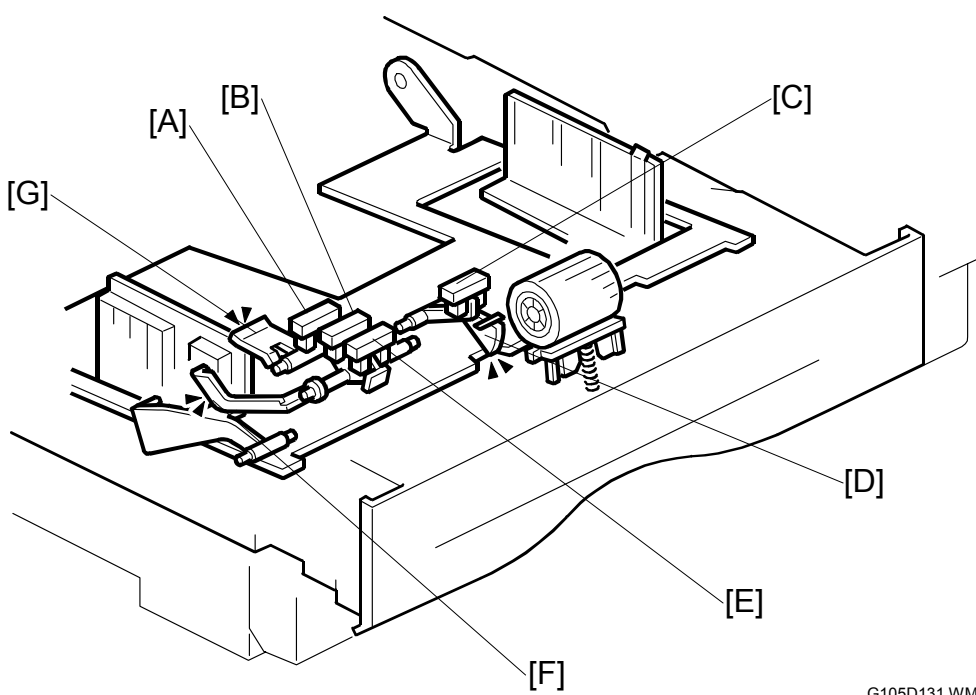

G105D131.WMF

There are four sensors in tray 1: the two near end sensors [B] [E], the end sensor [C] and the paper width sensor [A].

Near-end detection

Two near end sensors-detect the amount of paper in the tray.

When the quantity of paper decreases, the bottom-plate-pressure lever moves up and the actuator [F] (on the pressure-lever drive shaft) turns.

Remaining paper	Near end sensor 1 [E]	Near end sensor 2 [B]
Full ~ 450	ON	OFF
450 ~ 250	ON	ON
250 ~ 50	OFF	ON
50 ~ 0	OFF	OFF

OFF: No actuator

End detection

When the paper tray is empty, the actuator [D] goes into the end sensor. The sensor detects paper end.

Paper width sensor

When paper with a small width (less than A5) is put in the tray, it does not lift the actuator [G] of the paper width sensor. Because of this, the paper width sensor detects the paper that has a width less than A5.

Detailed Descriptions

By-pass Tray Feed and Size Detection

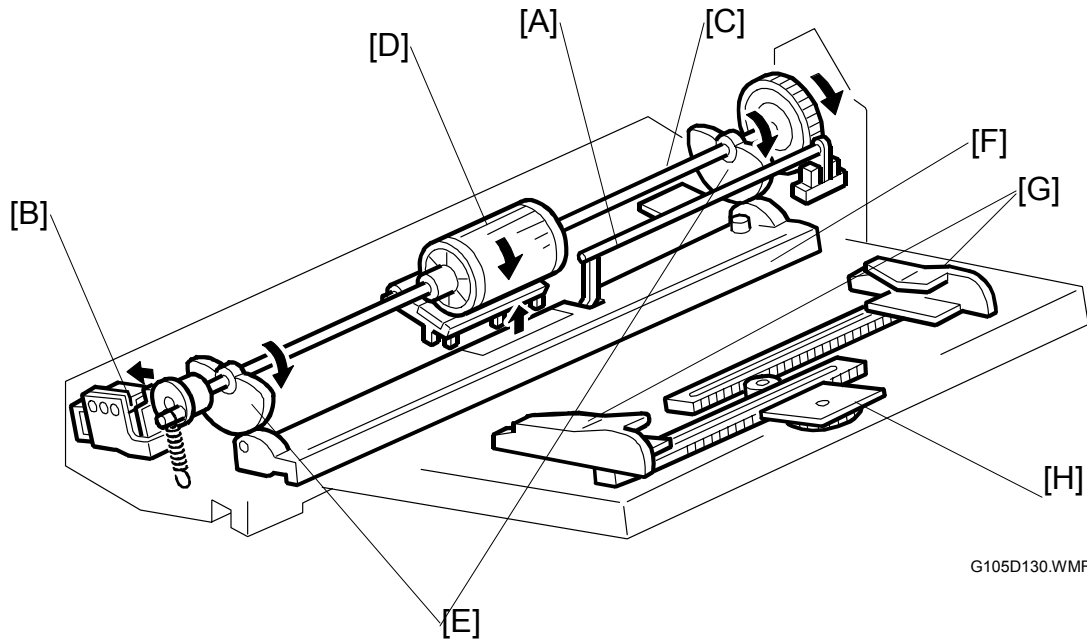

Paper Feed Mechanism

When the paper detection feeler [A] detects a sheet of paper, the by-pass solenoid [B] unlocks the feed shaft stopper at the left end of the by-pass feed shaft [C].

The by-pass feed shaft has the feed roller [D] and two cams [E]. These cams move the paper support plate [F] up and down. This pushes the sheets of paper against the feed roller.

Paper Size Detection Mechanism

There are two paper side plates [G] on the by-pass tray. These connect with the paper size sensor [H] through a rack-and-pinion mechanism.

6.3.4 DUPLEX

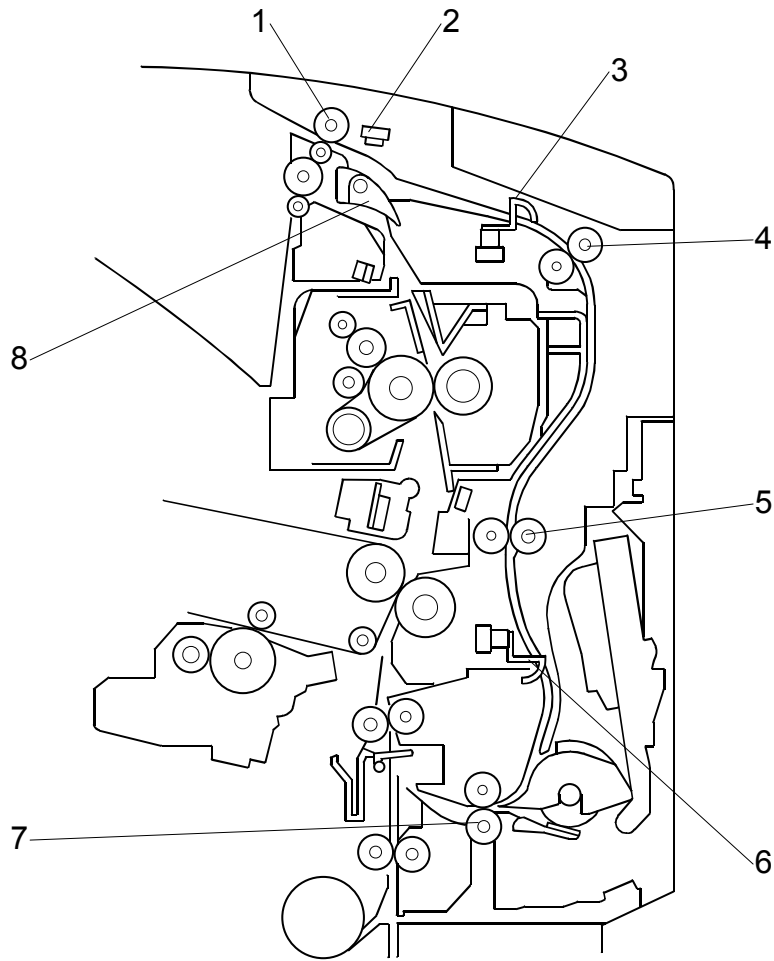

G105D122.WMF

- | | |
|---------------------------|------------------------|
| 1. Inverter roller | 5. Duplex relay roller |
| 2. Inverter sensor | 6. Duplex jam sensor 2 |
| 3. Duplex jam sensor 1 | 7. Duplex exit sensor |
| 4. Duplex entrance roller | 8. Junction gate |

Detailed
Descriptions

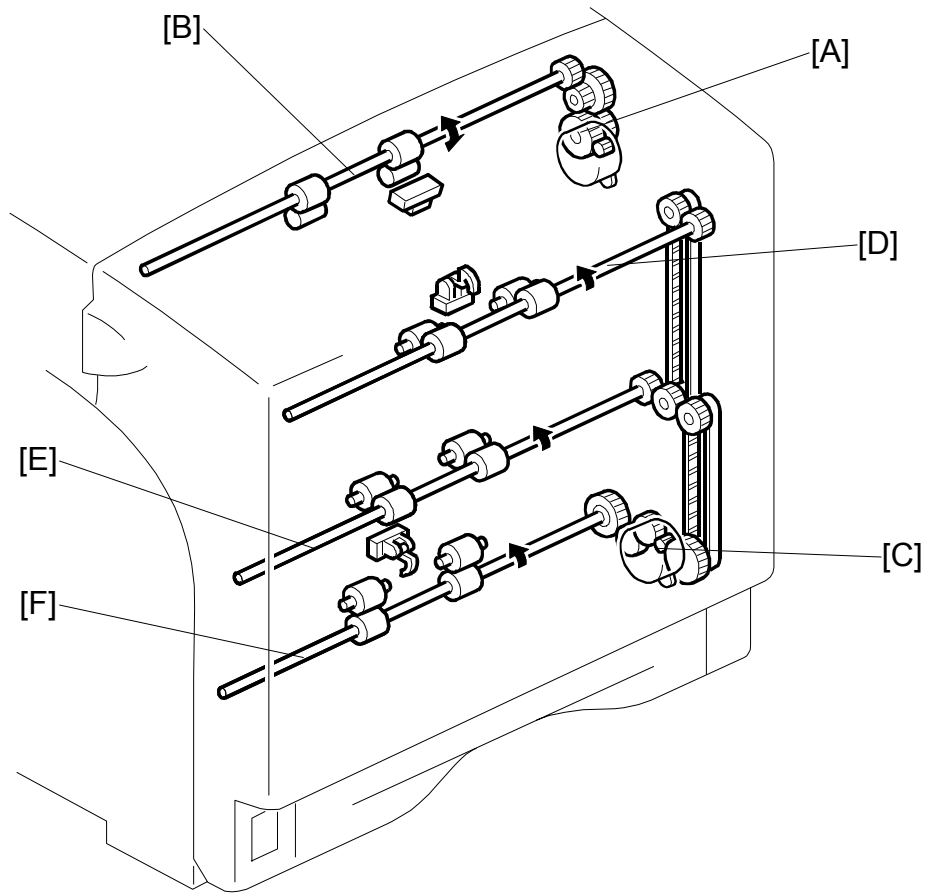
Drive

G105D123.WMF

The inverter motor [A] controls the inverter roller [B] that feeds the sheet of paper to the duplex unit.

The duplex motor [C] controls the duplex entrance roller [D], duplex relay roller [E] and duplex exit roller [F] that feed the sheet of paper to the registration roller.

Interleaving

Step 1:

This duplex unit uses the interleaving mechanism. This decreases the total time of duplex printing.

The machine prints on side [1]. Then, the first sheet of paper is fed out of the exit, but not fully.

Then the exit roller changes direction and the paper goes to the duplex feed path. At the same time, the second sheet of paper is fed between the transfer belt and the transfer roller, and side [3] is printed.

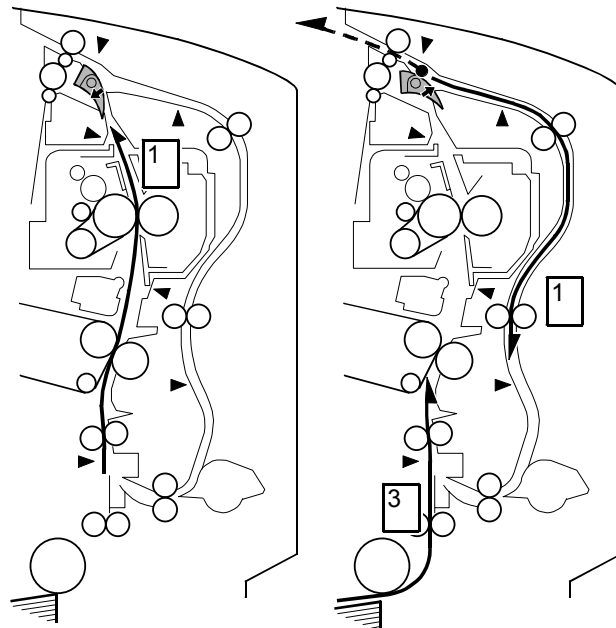

G105D124.WMF

Step 2:

The machine prints side [3] on the second sheet of paper.

The second sheet of paper is fed to the paper exit, and into the duplex feed path. At the same time, the first sheet of paper is fed between the transfer belt and the transfer roller, and side [2] is printed.

The second sheet of paper immediately follows the first sheet of paper in the duplex feed path. Then side [4] is printed.

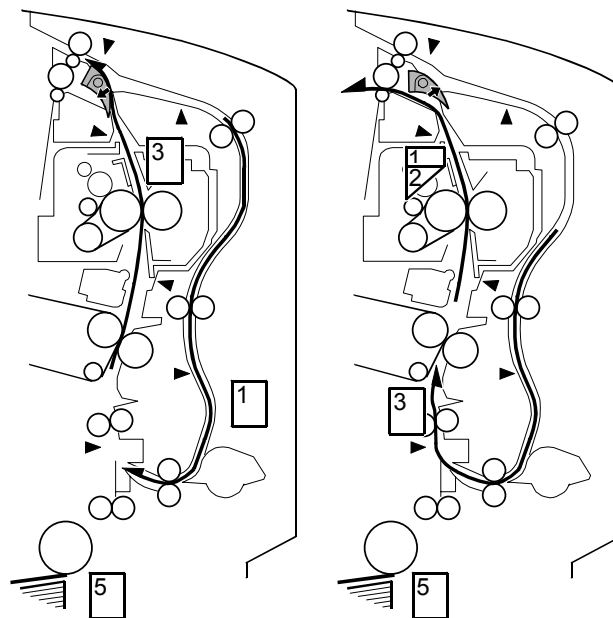

G105D125.WMF

Detailed Descriptions

6.4 LASER EXPOSURE

6.4.1 OVERVIEW

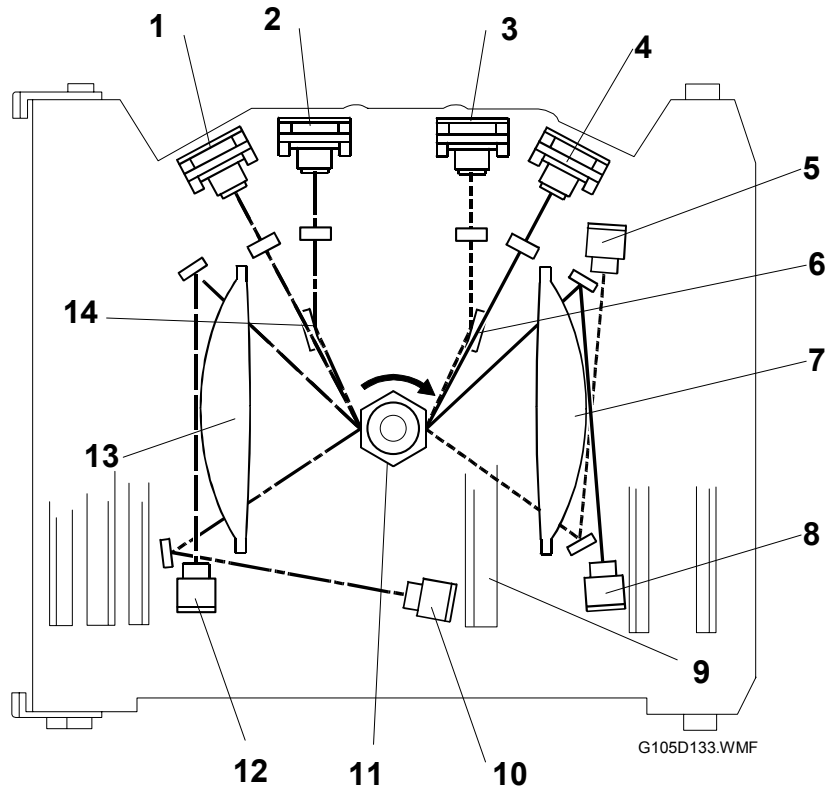

- | | |
|--|---|
| 1. LDB unit-C | 8. Synchronizing detector board-M, K-S |
| 2. LDB unit-Y | 9. Mirror |
| 3. LDB unit-K | 10. Synchronizing detector board-Y, C-S |
| 4. LDB unit-M | 11. Polygon mirror motor |
| 5. Synchronizing detector board-M, K-E | 12. Synchronizing detector board-Y, C-E |
| 6. LD Mirror-K | 13. F-theta lens-Y, C |
| 7. F-theta lens-M, K | 14. LD Mirror-Y |

This machine uses four LDB units and one polygon mirror motor to produce latent images on four OPC drums (one drum for each color toner).

There are two hexagonal mirrors. Each mirror reflects beams from two LDB units.

Laser exposure for yellow and cyan starts from the right side of the drum, but for magenta and black it starts from the left side of the drum. This is because the units for yellow and cyan are on the other side of the polygon mirror from the units for magenta and black.

6.4.2 OPTICAL PATH

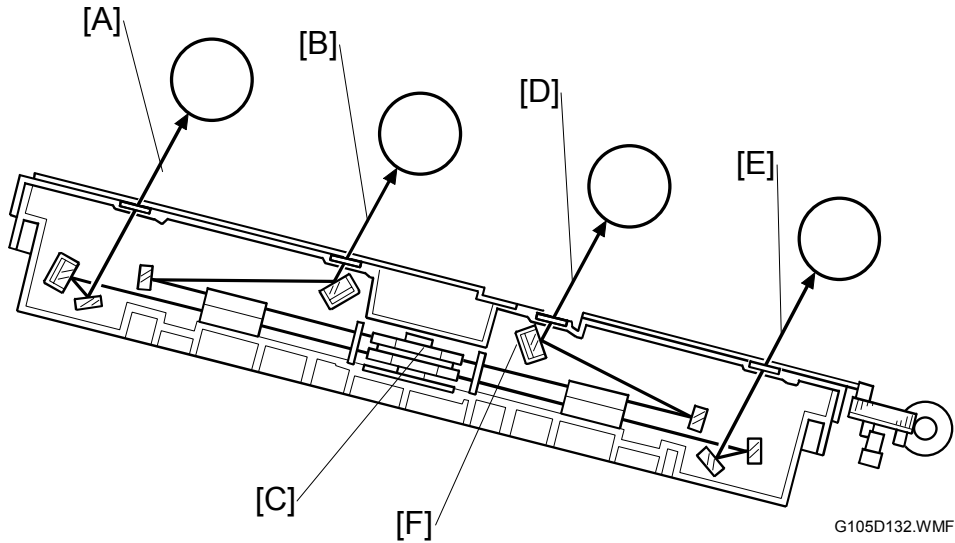

The laser beams for cyan [B] and magenta [D] are sent to the upper part of the polygon mirror [C]. The laser beams for yellow [A] and black [E] are sent to the lower part of the polygon mirror. The LD mirrors (see the previous page) reflect the laser beams for yellow and black to the lower polygon mirror.

The mirror [F] corrects the main scan line. Without this mirror, the line bends at the middle of the main scan. The central bend of the mirror is adjusted in the factory.

The speed of the polygon mirror is controlled by the selected mode (see below).

Mode	Resolution (dpi)	Polygon motor speed (rpm)	Process line speed (mm/s)	Print speed (ppm)
B/W (except OHP/Thick paper)	600 x 600	36614	155	25
	1,200 x 600			
Color (except OHP/Thick paper)	600 x 600	36614	155	25
	1,200 x 600			
OHP/Thick	600 x 600	36614	77.5	12.5
	1,200 x 600			
	1,200 x 1,200			

Detailed Descriptions

6.4.3 LASER SYNCHRONIZING DETECTOR

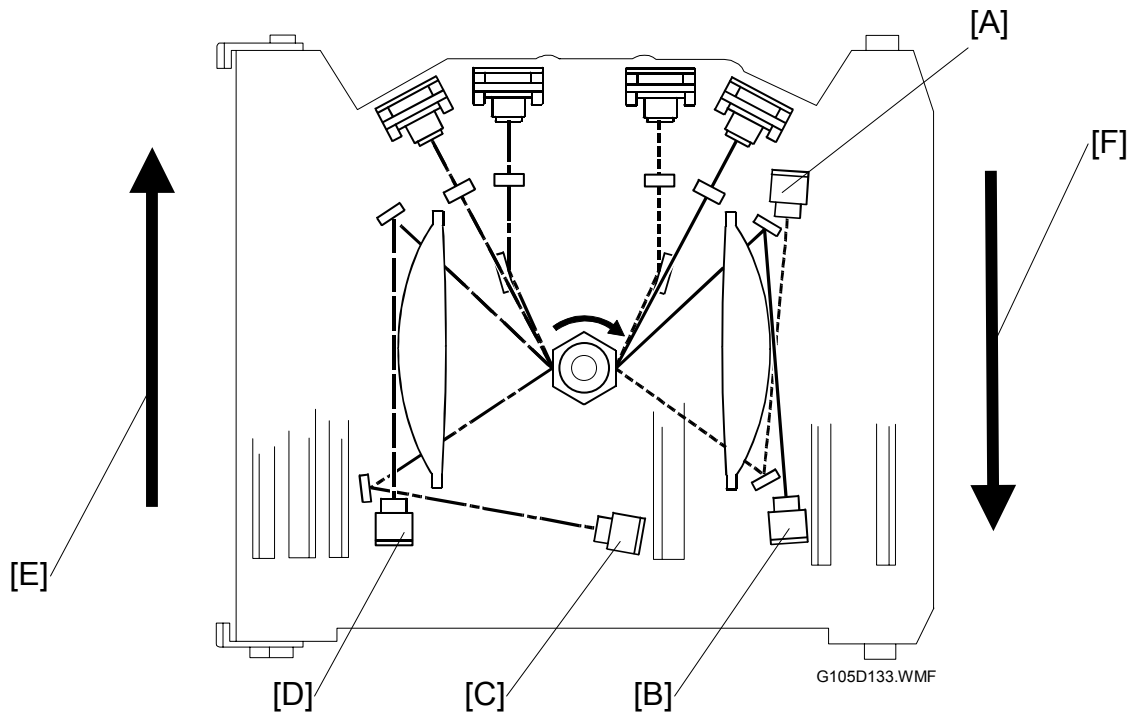

Overview

The machine has four laser synchronizing detector boards (LSD) as shown above. Each pair of boards detects two colors. The machine knows each color from the time that they are detected. The two LSDs [A] [B] are used for magenta and black, and the two [C] [D] are used for yellow and cyan.

Main Scan Start Detection

For magenta and black, the LSD [B] detects the start of the main scan. For yellow and cyan, the LSD [C] detects the start of the main scan. The arrows [E] [F] show the direction of the laser scan.

6.4.4 LD SAFETY SWITCH

A safety switch turns off when the front cover or the right door is opened. As a result, the relay on the PSU cuts off the power supply (+5V) to the four LD boards. (The electric circuits go through the EGB and IOB.)

The LD safety switch system stops the laser beam when the cover is open.

Front and Upper Right Cover Switch

The front cover and the right cover are mechanically connected to the actuator. The actuator is mechanically connected to the safety switch. When one of these covers is opened or closed, the actuator opens or closes the switch.

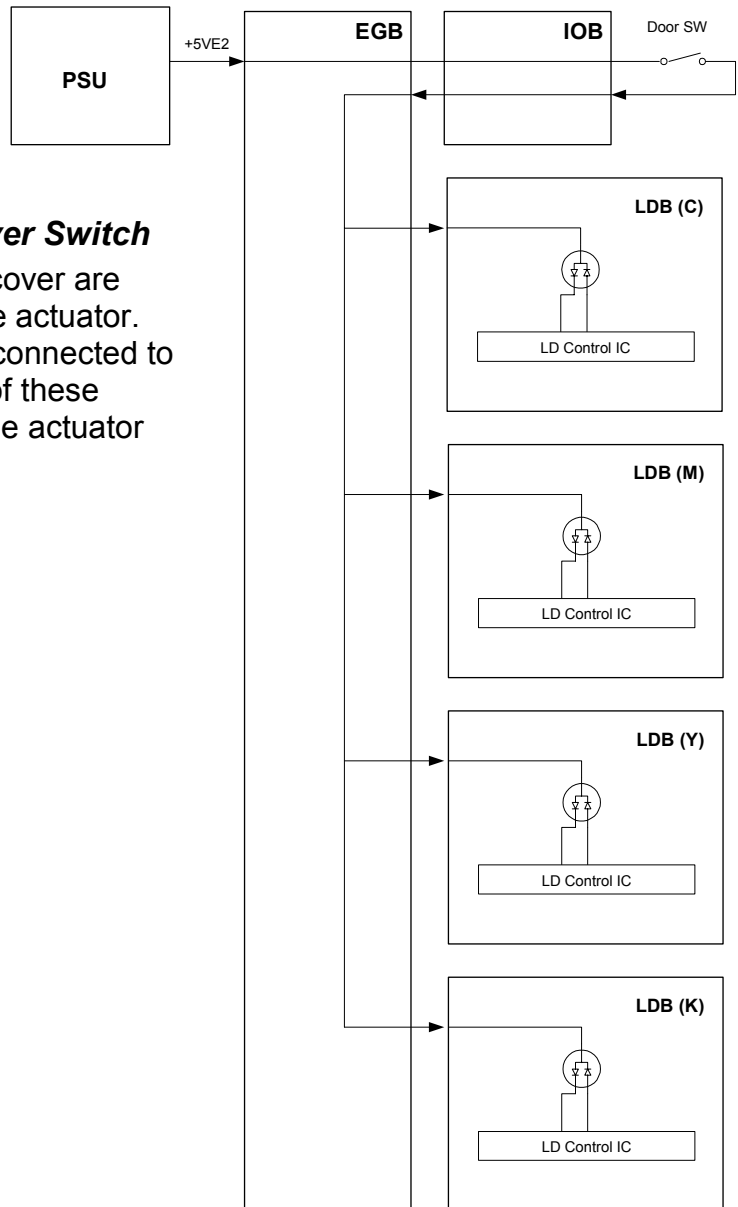

G105D901.WMF

6.4.5 AUTOMATIC LINE POSITION ADJUSTMENT

Overview

YY, KK, CC, MM: Spaces between two lines of the same color
KY, KC, KM: Spaces between a black line and a color line

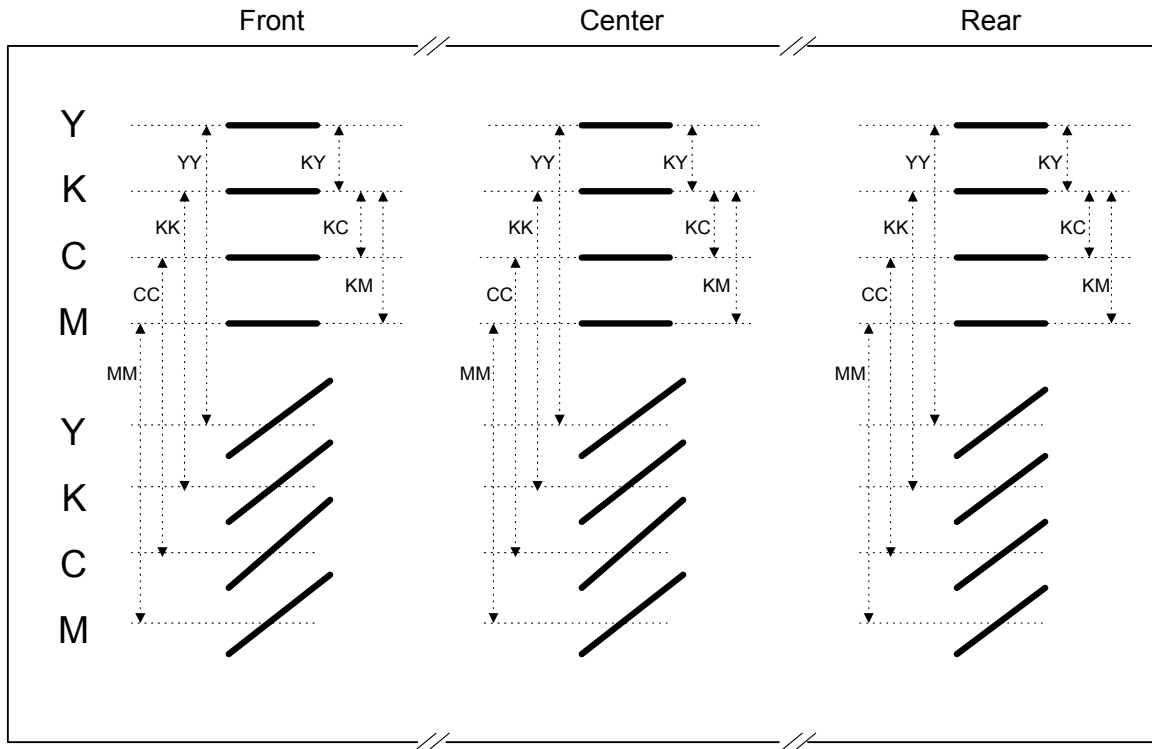

G105D921.WMF

During automatic line position adjustment, the line patterns above are made eight times on the transfer belt. The spaces between the lines (YY, KK, CC, MM, KY, KC, KM) are measured by the front, center, and rear ID sensors. The controller reads the average of the spaces, and adjusts these items:

- Sub scan line position for YCM
- Main scan line position for KYCM
- Magnification ratio for KYCM
- Skew for YCM (NOTE)

NOTE: In this procedure, only the skew for YCM is measured. If you want to adjust it, do the main skew adjustment procedure. (3.3.2)

The transfer-belt-cleaning unit cleans the transfer belt after the patterns are measured.

Summary of Each Adjustment

Sub scan line position for YCM

The adjustment of the sub-scan line position for YCM uses the line position for K (color registration). The machine measures the gaps between the lines of each color in the pattern on the transfer belt. If the gaps for a color are not correct, the machine moves the image of the color up or down the sub scan axis. To do this, it changes the laser write timing for that color.

Main scan line position for KYCM

If the machine detects that the image is out of position in the main scan direction, it changes the laser-write-start timing for each scan line.

Magnification adjustment for KYCM

If the machine detects that magnification adjustment is necessary, it changes the LD clock frequency for the necessary color.

Skew for YCM

The adjustment of the skew for YCM uses the line position for K.

Adjustment Conditions

If SP 2153-001 is set to 'on', then automatic line position adjustment is done at the times shown below.

After process control is done

If SP 2153-002 is set to 'on', then the adjustment is done when these types of process control are successfully done.

- Initial process control
- Interval process control
- No-use time process control

Initialization

If SP 2153-003 is set to 'on', then the adjustment is done when the main power is turned on or the machine comes back from the standby mode, but only if one of the following conditions occurs.

- At a set time after the previous adjustment. The default value is 360 minutes. You can adjust the time with SP2153-013.
- When the temperature changed after a previous adjustment by more than a set value. The default value is 5. You can adjust the temperature change value with 2153-012.

Printing

If SP 2153-004 is set to 'on', then the adjustment is done when the machine gets print job data, but only if one of the following conditions occurs.

- At a set time after the previous adjustment. The default value is 360 minutes. You can adjust the time with SP2153-013.
- When the temperature changed after a previous adjustment by more than a set value. The default value is 5 °C. You can adjust the temperature change value with SP2153-012.
- When the magnification changed after a previous adjustment by more than a set value. The default value is 1 %. You can adjust the magnification change value with SP2153-015.

Interrupt

If SP 2153-005 is set to 'on', then the adjustment is done when the one of the following conditions occurs during a print job with many pages.

- When the number of printed pages after the previous adjustment becomes more than a set number. The number of pages includes black and color printing. The default value is 190 pages. (If this condition occurs, automatic line position adjustment after the next interval process control will not be cancelled.) You can adjust the default value with SP2153-010.
- When the temperature changed after a previous adjustment by more than a set value. The default value is 5 °C. You can adjust the temperature change value with SP2153-012.
- When the magnification changed after a previous adjustment by more than a set value. The default value is 1 %. You can adjust the magnification change value with SP2153-015.

This table shows when the automatic line position adjustment is done. It also shows the main SPs that control the timing of the adjustment. If SP 2153 001 is 'off', then the automatic adjustment is never done. Note that the adjustments for the sub-scan line position, main scan line position, and magnification are done at the same time.

Enabled/Disabled (SP 2153 001)	After Process Control (SP 2153 002)	Initialization (SP 2153 003)	Printing (SP 2153 004)	Interrupt (SP 2153 005)	Remarks
On	ON	On	ON	On	Default
			Off	Off	
			Off	On	
		Off	ON	On	
			Off	Off	
			Off	On	
	Off	On	ON	On	
			Off	Off	
			Off	On	
		Off	ON	On	
			Off	Off	
			Off	On	
Off	-	-	-	-	No Adjustment

Detailed Descriptions

NOTE: You can also do the automatic line position adjustment manually with SP2111-001.

Main Scan Skew Adjustment

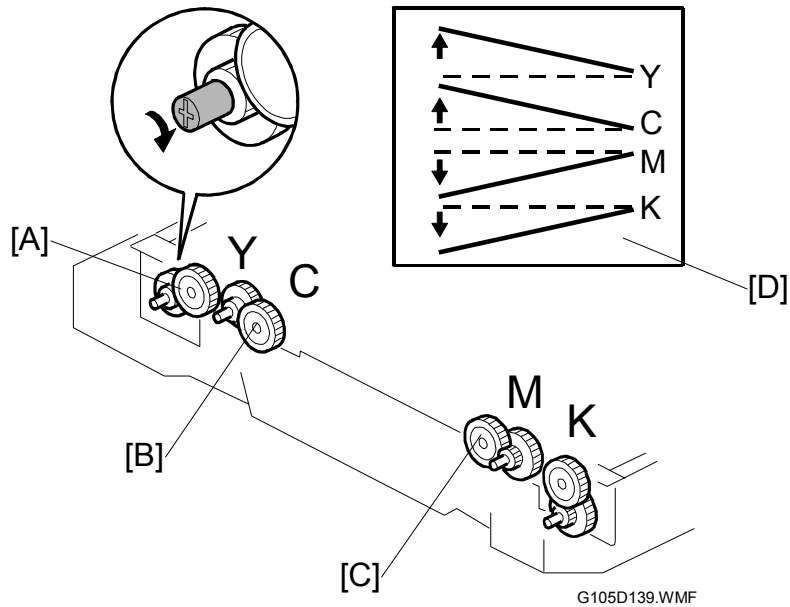

You can adjust the mirror adjustment cam for magenta [C], cyan [B], and yellow [A] with a screwdriver. This mechanism corrects the main scan skew. The diagram shows the effect on line skew [D] when you turn the cam in a counterclockwise direction.

For more about this adjustment, see section 3.3.2.

LDU Shutter

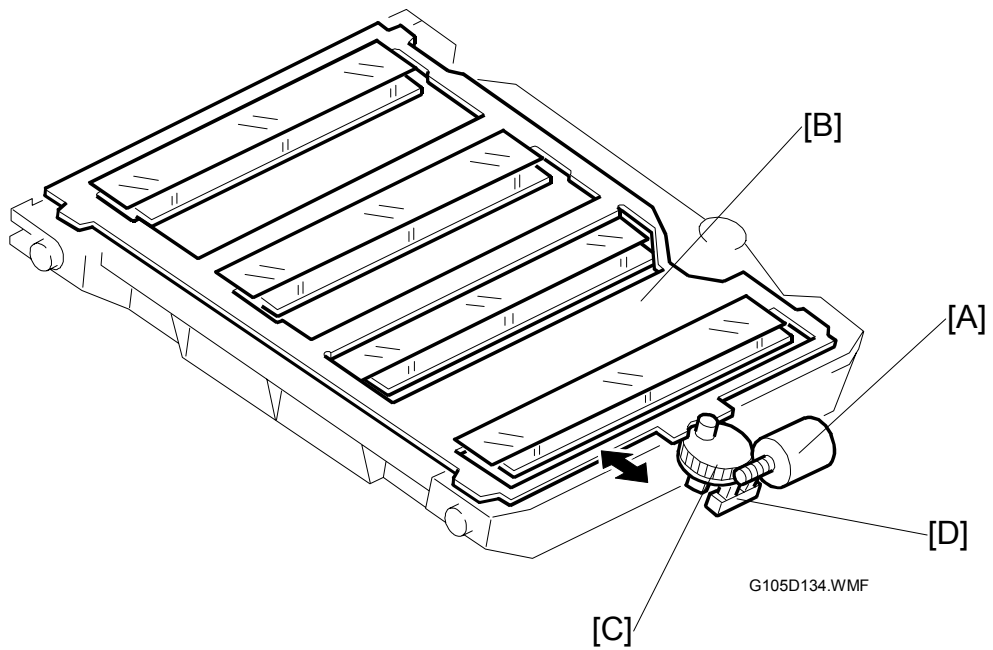

The LD unit has a shutter. As a result, toner and other dust does not fall on the LDU glass. The shutter motor [A] moves the shutter [B] in the direction of the arrow with the gear [C]. SC270 occurs if the output of the LDU shutter sensor [D] does not change 1 second after the LDU shutter motor turned on.

Detailed
Descriptions

6.5 PHOTOCONDUCTOR UNIT

6.5.1 OVERVIEW

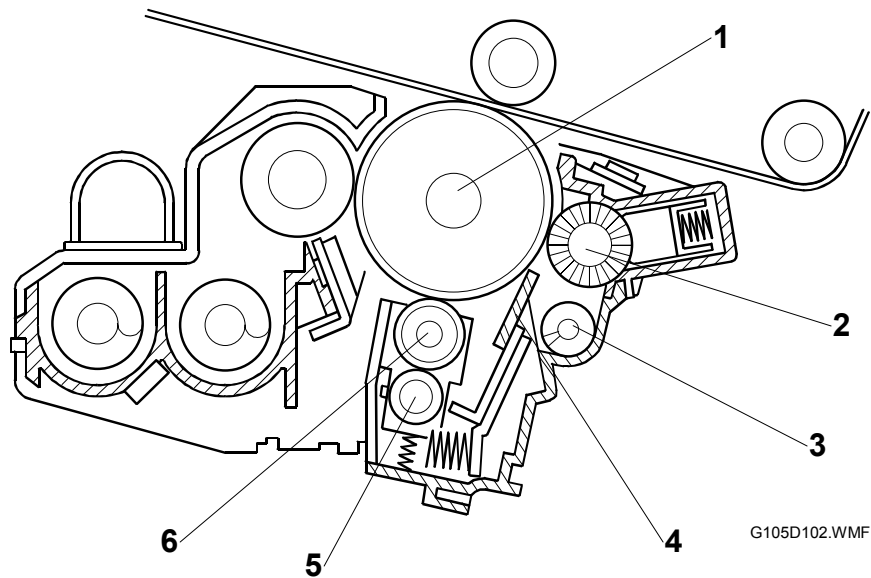

- | | |
|--------------------------------|--------------------------|
| 1. OPC drum | 4. Cleaning blade |
| 2. Cleaning brush | 5. Cleaning brush roller |
| 3. Waste toner collection coil | 6. Charge roller |

This machine has four PCUs, one for each color. Each PCU contains an OPC drum, charge roller, cleaning brush, and cleaning blade. The diameter of the drum is 30 mm (circumference: about 94.2 mm).

The photoconductor gap between each PCU and development roller is set by the drum positioning plate and the rear shaft. It is not adjustable in the field.

6.5.2 DRIVE AND DRIVE GEAR POSITION SENSOR

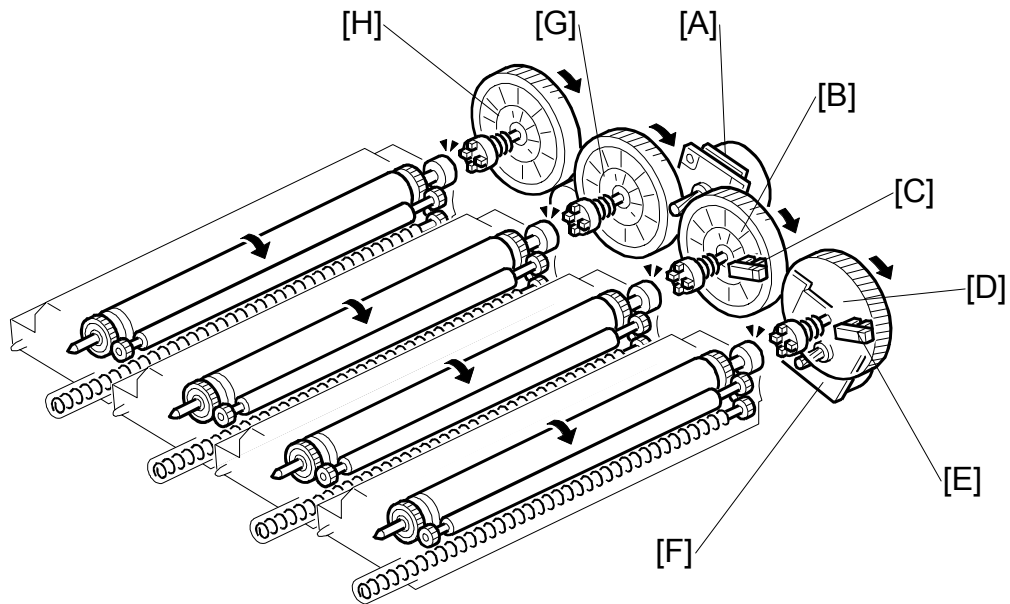

G105D105.WMF

The black OPC/development motor [F] controls the PCU for black.

The color development motor [A] controls the PCUs for magenta, cyan, and yellow. One motor controls these three drums to help reduce the CMY color registration errors.

Mechanism

The machine uses the drum gear position sensors to detect if the drum motors turn. SC380 occurs when it detects that the drum motor does not move. These sensors also help the machine to initialize the positions of the gears when the main switch is turned on and at initialization. This prevents changes between printouts in how the gears engage. This can cause changes in copy quality.

There is an actuator on each of the black [D] and magenta [B] drum gears. The drum gear position sensors [C][E] detect the positions of these actuators. The sensors check that the two actuators are parallel. This mechanism makes sure that output quality does not change. The cyan [G] and yellow [H] drum gears operate with the magenta drum gear because these three drum gears are connected through other gears.

In the ready condition, the two actuators are parallel. If they are not in a parallel position, the machine adjusts the position of the black drum gear.

Initialization Process and SC Codes

When a drum gear position sensor has found an error, SC code 396 or 397 is shown. The table shows the steps of the initialization procedure, possible errors, and corresponding SC codes.

	Initialization process	Possible error	SC code
Step 1	The four drums turn at the same time for seven seconds. The two drum position sensors detect the two drum gear interrupters several times.	The black drum gear actuator is not detected.	396
		The color drum gear actuator is not detected.	397
		Both black and yellow drum gear actuators are not detected.	396
Step 2	The time lags between detection of the black drum gear interrupter and detection of the color drum gear interrupter are checked. The average time lag is calculated.		
Step 3	The black drum turns. The position of the gear is adjusted for the average time difference.	The black drum gear actuator is not detected (●NOTE).	396

NOTE: If the connector of the black drum position sensor is connected to the yellow drum position sensor (and the connector of the yellow drum position sensor is connected to the black drum position sensor), no error occurs in step 1 and step 2.

6.5.3 DRUM CHARGE AND QUENCHING

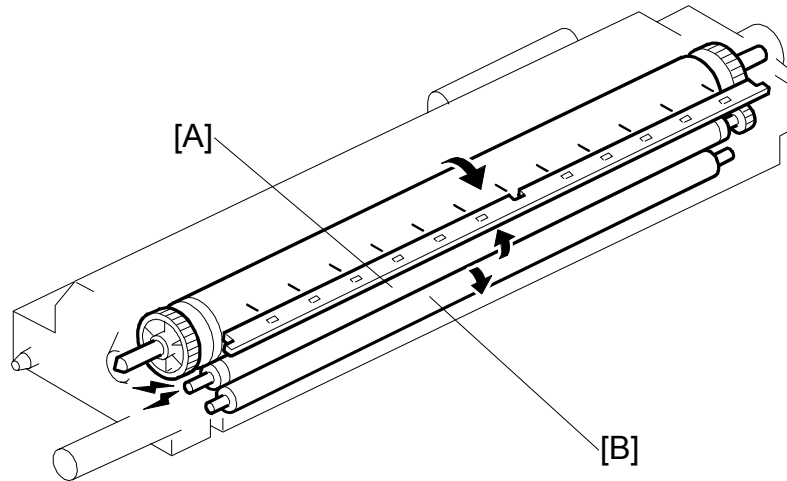

G105D103.WMF

This machine uses a charge roller [A]. The charge roller gives the drum surface a negative charge. The high voltage supply board, which is at the rear of the machine, applies a dc and ac voltage (at a constant current) to the roller. The ac voltage helps to make sure that the charge given to the drum is as constant as possible.

The machine automatically controls the charge roller voltage if automatic process control is enabled (that is, if SP3-501-001 is set to 0). However, if process control is turned off, (that is, if SP3-501-001 is set to 1), the dc voltage is the value stored in SP2-201-001 to -004 or SP2-201-006 to -009 (do not adjust in the field unless told to do this).

The diameter of the roller is 30 mm (the circumference is about 94.2 mm).

The cleaning brush roller [B], which always touches the charge roller, cleans the charge roller.

For quenching at the end of every job, light from the quenching lamp (LED array in the PCU) hits the full area of the drum.

6.5.4 DRUM CLEANING

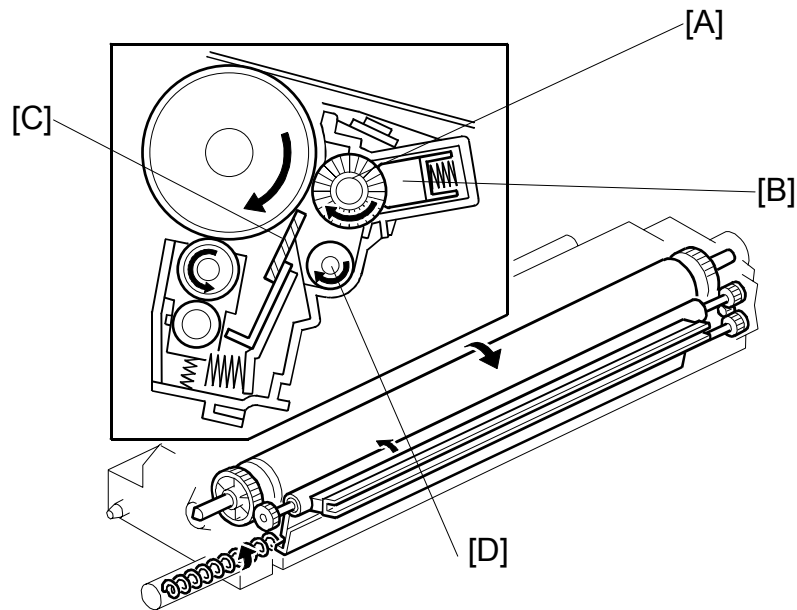

G105D104.WMF

The cleaning brush [A] makes flat the waste toner on the drum. The lubricant bar [B] lubricates the brush. The cleaning blade [C] then removes the waste toner. The toner collection coil [D] moves the toner to the waste toner collection duct.

6.5.5 WASTE TONER COLLECTION

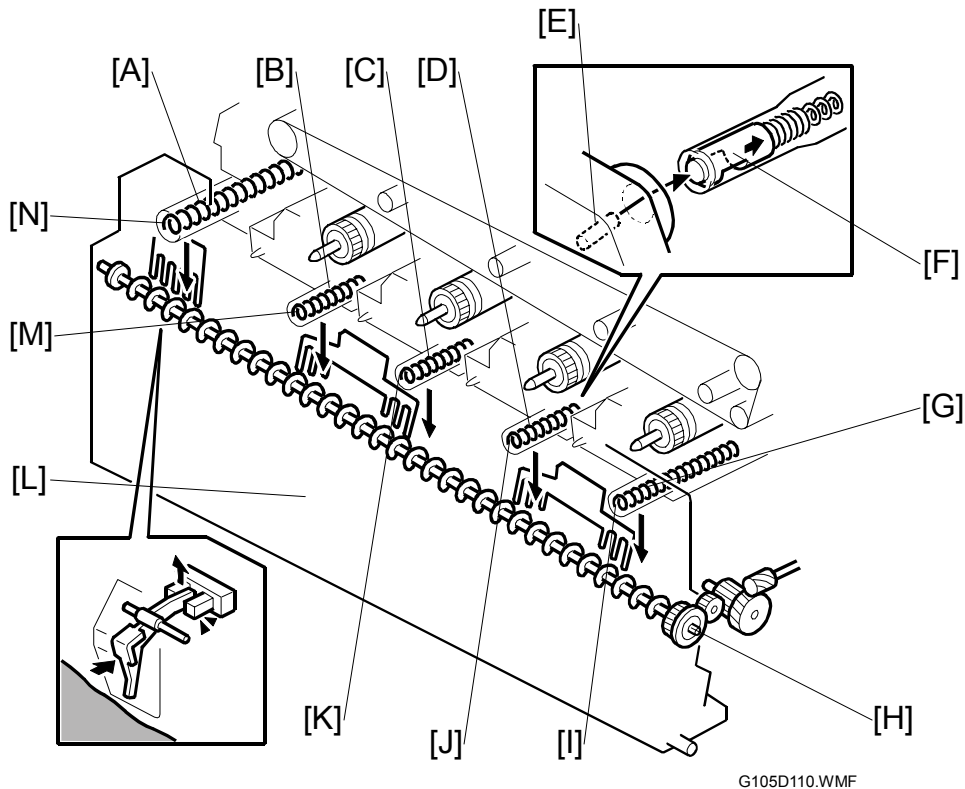

The waste toner from the collection coils in the four PCUs falls into the waste-toner collection bottle from the four openings [I][J][K][M] at the rear of the PCUs. The toner collection coils [B][C][D][G] move this waste toner to the waste toner bottle [L].

Coils [B][C][D] are controlled by the color development motor and coil [G] is controlled by the black OPC/development motor.

NOTE: The openings [I] to [M] are for these PCUs: black → [I], cyan → [J], magenta → [K], yellow → [M].

The waste toner from the transfer-belt cleaning unit falls into the waste toner collection bottle from a different opening [N]. The toner collection coil [A] moves this waste toner to the waste toner bottle.

The waste toner collection coil [H] is controlled by the transfer roller contact motor.

The waste toner bottle has five seals (one at each entrance). These prevent scattering waste toner.

The pin [E] at the waste toner entrance pushes the shutter spring [F] in the rear of the PCU. Because of this, waste toner can fall into the waste toner bottle. If the left cover is open, the waste toner does not come out from the rear of the PCUs.

6.5.6 WASTE TONER BOTTLE FULL DETECTION AND SET DETECTION

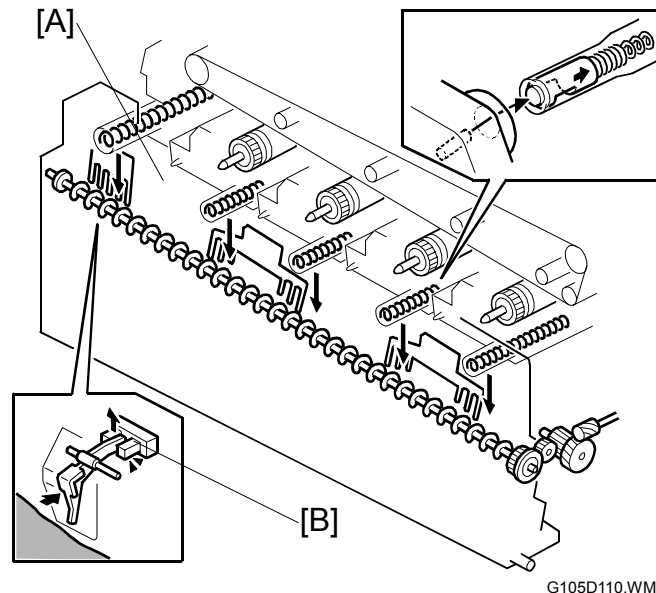

The left cover sensor [A] in the main frame detects when the left cover is open. It also detects if the waste toner bottle is put in the machine. If the “Close Front/Left Cover” shows on the LCD when the cover is closed, check if the waste toner bottle is in the machine.

The waste toner sensor [B] detects when the bottle is almost full.

When the bottle contains a set quantity of waste toner, the sensor turns off. The machine detects that the waste toner bottle is almost full.

After that, the machine can print approximately 1250 more sheets. After printing 1250 sheets, it shows “Replace Waste Toner bottle” and after the end of the job, the printer cannot be used until the bottle is replaced or emptied.

NOTE: The number of sheets is calculated for a paper size of A4 and an image coverage ratio for each color of 5%.

6.5.7 PCU DETECTION (DEVELOPMENT UNIT DETECTION)

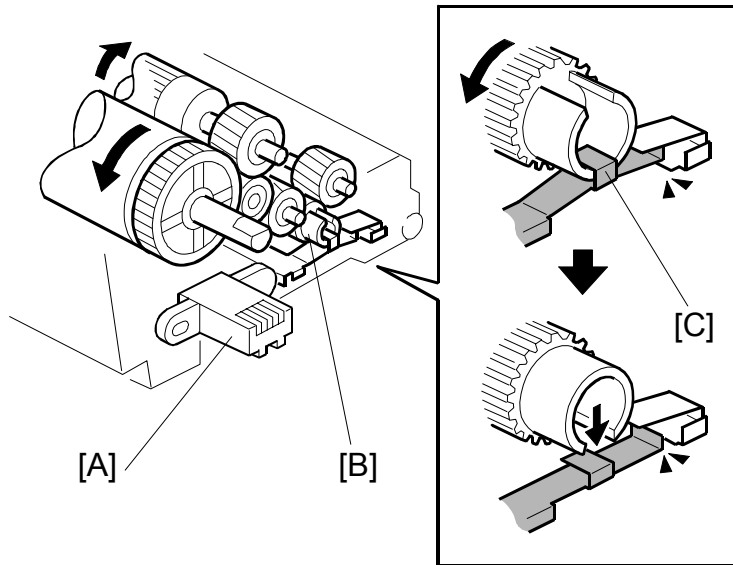

G105D109.WMF

Unit Set Detection Pins

Each PCU has a connector [A]. The machine uses this to detect if the PCUs and development units are in the machine. Each PCU is detected through this connector when the drum positioning plate is closed.

New Unit Detection

Each PCU also has a circular hook [B]. The machine uses this to detect when a new PCU is installed.

On a new unit, the hook holds up the terminal [C]. This hook turns the switch on, and the machine detects that the unit is new.

When the unit operates for the first time, the hook turns and releases the terminal and the switch turns off. The hook cannot pick up the terminal again. Because of this, the machine detects that this PCU is not new.

Detailed Descriptions

Error Message***PCU***

When the machine cannot detect a PCU, it outputs the first message, "Reset PCU Correctly," and the second message, "Xxxx"; where "Xxxx" is a color, for example "Magenta". The operation panel shows the first message and then shows the second message, and then back to the first. Each message is shown for 3 seconds.

If two or more PCUs are not detected, the second message shows those colors, for example "Yellow/Cyan" and "Yellow/Magenta Black".

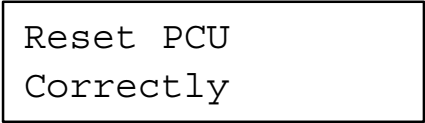

Reset PCU
Correctly

G105D908.WMF



Magenta

G105D909.WMF



Yellow/Cyan

G105D910.WMF

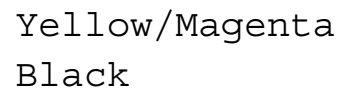

Yellow/Magenta
Black

G105D911.WMF

6.6 DEVELOPMENT

6.6.1 OVERVIEW

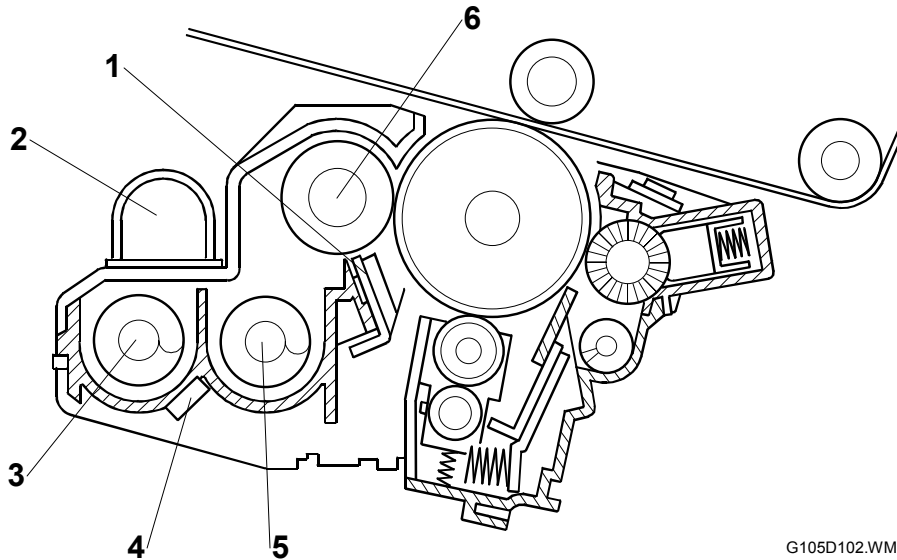

G105D102.WMF

- | | |
|-----------------------|------------------------|
| 1. Doctor blade | 4. TD sensor |
| 2. Developer hopper | 5. Mixing coil (right) |
| 3. Mixing coil (left) | 6. Development roller |

This machine has four development units, one for each color. The developer in each unit is supplied to the development roller by the two mixing coils. Electrostatic attraction moves the developer to the surface of the roller.

The drum positioning plate and the rear shaft set the photoconductor gap between the PCU and development roller. It is not adjustable in the field.

The TD sensor detects toner density. Each development unit has a TD sensor.

The diameter of the development roller is 18 mm (the circumference is approximately 56.5 mm).

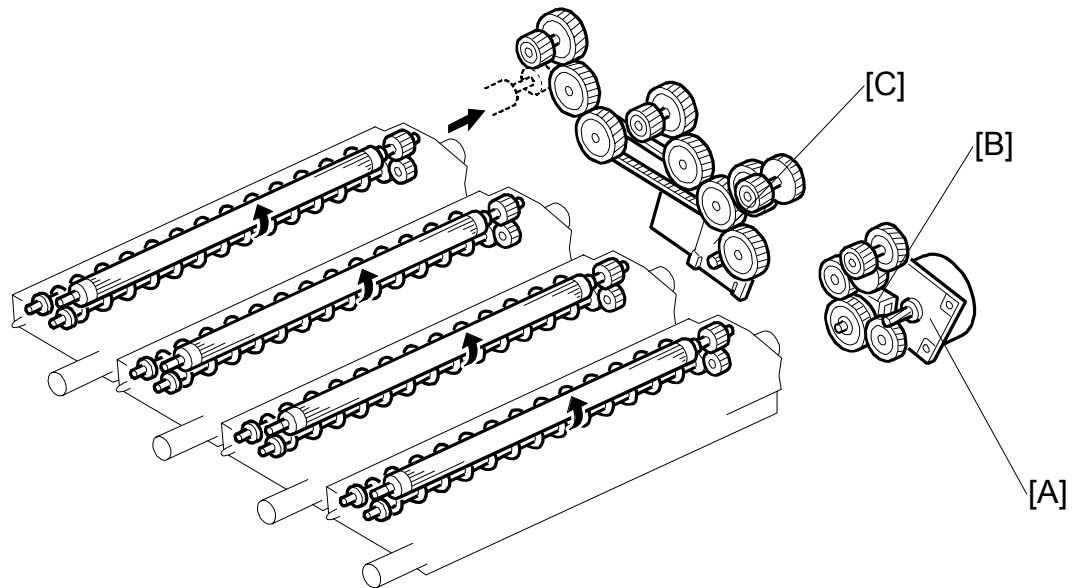
6.6.2 DRIVE

G105D108.WMF

The black development motor [A] drives the development roller and the photoconductor for black through gears and the development clutch [B].

The color development motor [C] drives the development unit for magenta, cyan, and yellow through gears.

The machine only contains one development clutch, and it is only used for black.

6.6.3 DEVELOPER MIXING

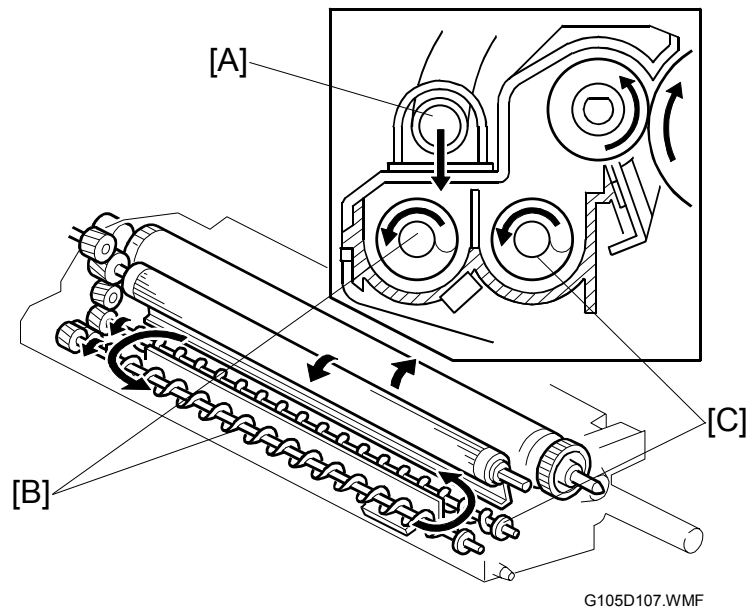

The toner is supplied from the hopper [A]. Two mixing coils [B and C] move the developer forward and rearward to mix the developer.

This occurs at these times:

- Immediately after a new PCU is installed.
- During the process control self check
- During toner supply
- During development.
- Every 36 hours (can be changed with SP 3554 003)
- If absolute humidity changes more than $\pm 6 \text{ g/m}^3$ (e.g. $23^\circ\text{C}/50\% \rightarrow 27^\circ\text{C}/70\%$).
The humidity threshold can be changed with SP 3554 004.

6.6.4 DEVELOPMENT BIAS

The high voltage supply board #2 supplies development bias to the development roller through the receptacle at the rear of each development unit.

There are ac and dc bias voltages. The ac bias improves toner transfer to the drum.

The machine automatically controls the dc bias, if automatic process control is enabled. However, if process control is turned off, (that is, if SP3-501-001 is set to 1), the dc bias is the value stored in SP2212-001 to -009 (do not adjust in the field unless told to do this).

6.6.5 TONER SUPPLY MECHANISM

Overview

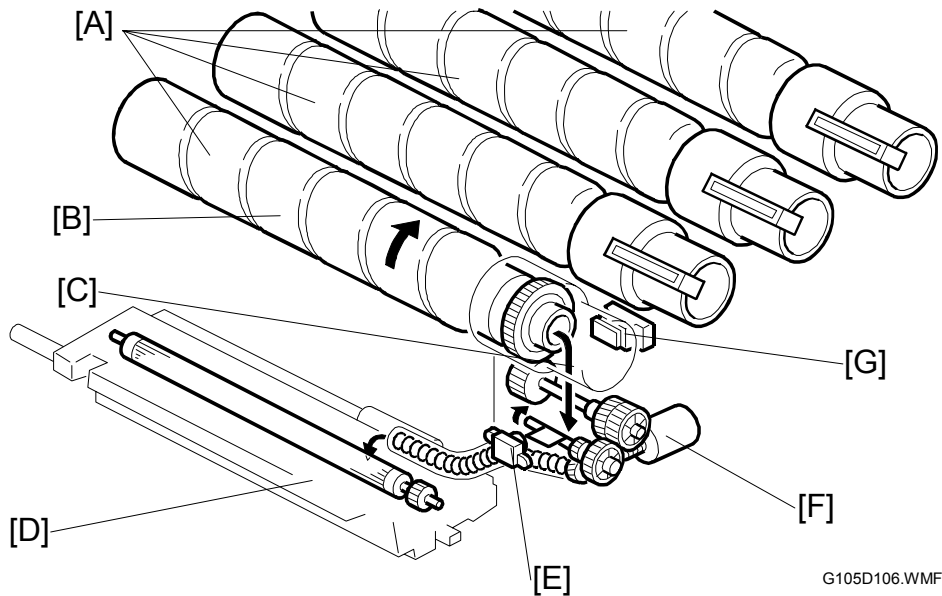

This machine uses four toner bottles [A]. Each bottle has a spiral groove [B] in it. The toner supply motor [F] turns the toner bottle (each bottle has a separate motor).

When the toner supply drive-mechanism starts, the toner bottles turn and the groove moves toner to the mouth of the bottle. Here, toner spills into a hopper [C]. Mylar blades turn and move the toner to an opening in the side of the hopper and the toner falls into the development unit [D]. The quantity of toner that is added is controlled by the length of time that the toner supply mechanism turns.

Toner Near End Detection

Toner end sensors [E] detect toner end conditions (☛ 6.2.5).

6.6.6 TONER BOTTLE DETECTION

Each toner bottle is detected by connection to the ID chip connector [G].

6.7 IMAGE TRANSFER

6.7.1 OVERVIEW

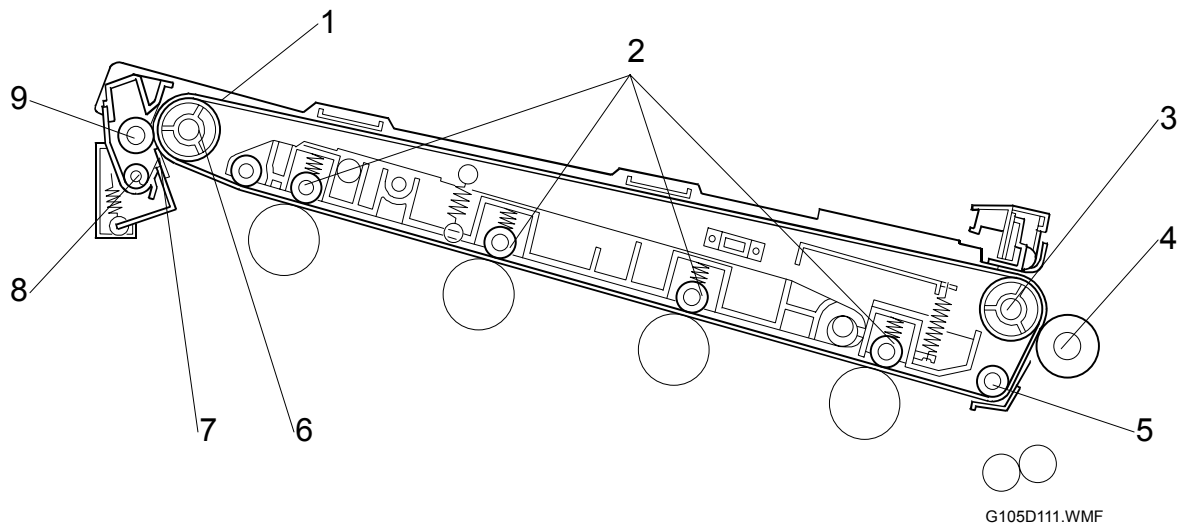

- | | |
|-------------------------------|---------------------------------|
| 1. Transfer belt | 6. Transfer belt tension roller |
| 2. Belt transfer roller | 7. Cleaning blade |
| 3. Transfer belt drive roller | 8. Toner collection coil |
| 4. Transfer roller | 9. Cleaning brush |
| 5. Belt entrance roller | |

The toner is moved from the four OPC drums to the transfer belt. For a full color print, all four colors are moved from the PCUs to the transfer belt at the same time. The transfer roller then moves the four-colour toner image from the transfer belt to the paper.

Transfer Unit Detection and New Unit Detection

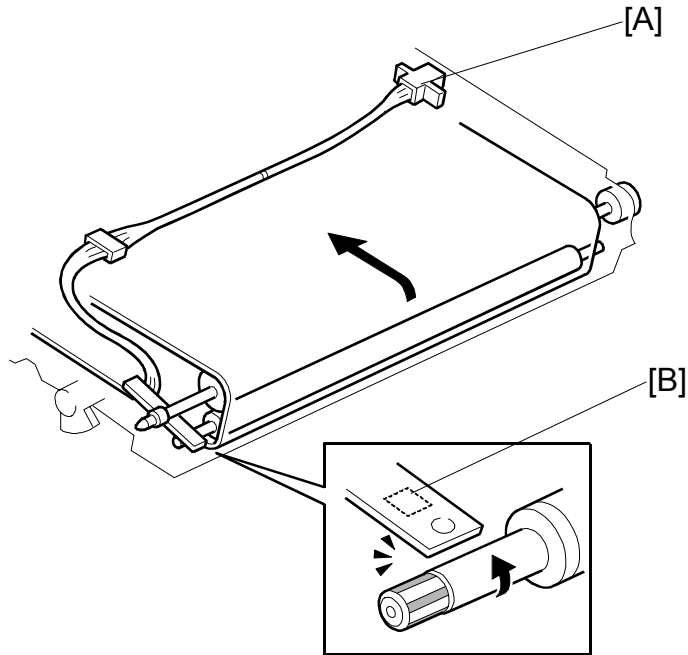

G105D115.WMF

Transfer belt unit detection

The transfer belt unit is detected when the connector [A] is connected.

The transfer belt rotation sensor [B] detects when the transfer belt entrance roller turns. It also detects the belt speed. To do this, it monitors the black and white stripes on the shaft.

Changes in temperature have an effect on the transfer belt drive roller. This can cause changes in belt speed. Color registration errors occur if belt speed is not constant. The rotation sensor detects the speed change and the machine keeps the transfer belt speed constant. You can enable or disable this belt speed correction with SP 2153 8.

Detailed
Descriptions

New transfer belt unit detection

The transfer belt rotation sensor has a fuse when the transfer belt unit is new. The fuse is blown when the machine is turned on. At this time, it is detected as a new unit.

6.7.2 DRIVE AND TRANSFER BELT ROLLER VOLTAGE

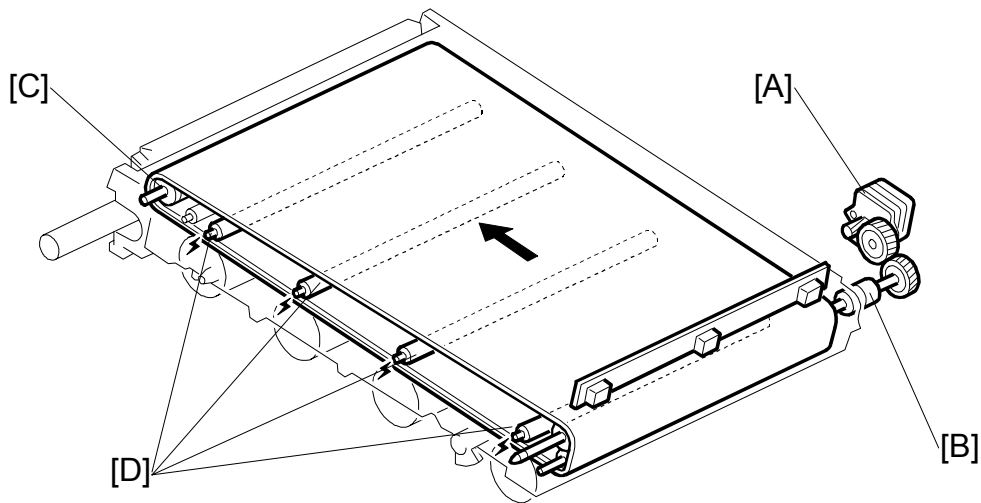

G105D112.WMF

The transfer belt motor [A] controls the transfer belt drive roller [B]. The belt tension roller [C] adds tension to the transfer belt to help to turn this belt. The speed of transfer belt drive is set by the process line speed.

The belt transfer rollers [D] are charged from the terminal plates to move the toner from the PCUs to the transfer belt.

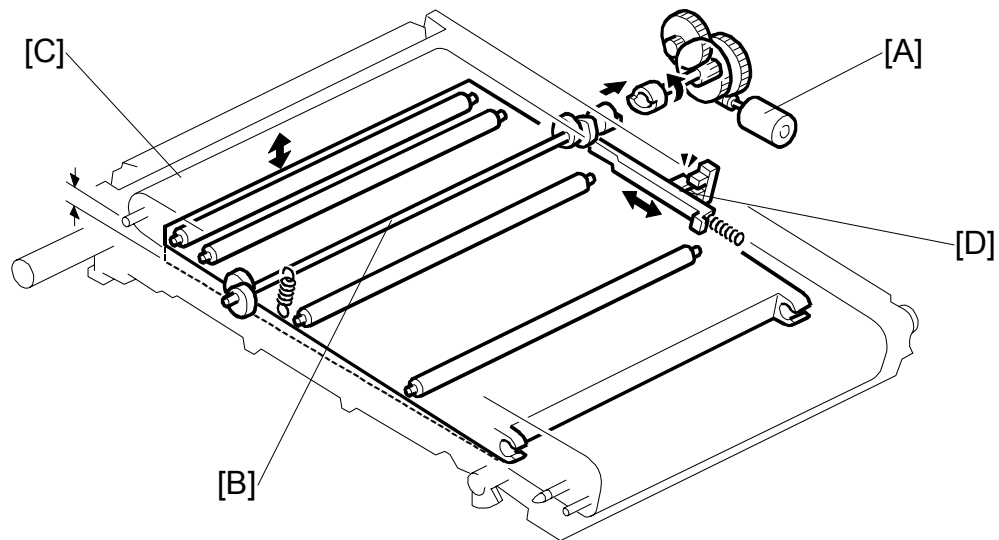
Transfer belt contact

G105D113.WMF

The transfer belt does not touch the color PCUs (cyan, magenta and yellow) when the machine makes a black and white print.

The transfer belt contact motor [A] turns the CMY contact cam shaft [B] when the machine starts to make a color print. The CMY contact cam lifts the belt transfer roller unit for CMY [C] to the transfer belt. Because of this mechanism, the life of the transfer belt is longer (it is not necessary for the transfer belt to touch the color PCUs when the machine makes a black and white print).

The transfer belt contact sensor [D] detects if the transfer roller unit for CMY touches the transfer belt. If it does not touch the transfer belt during color printing, the machine stops and shows SC 442.

Transfer belt cleaning

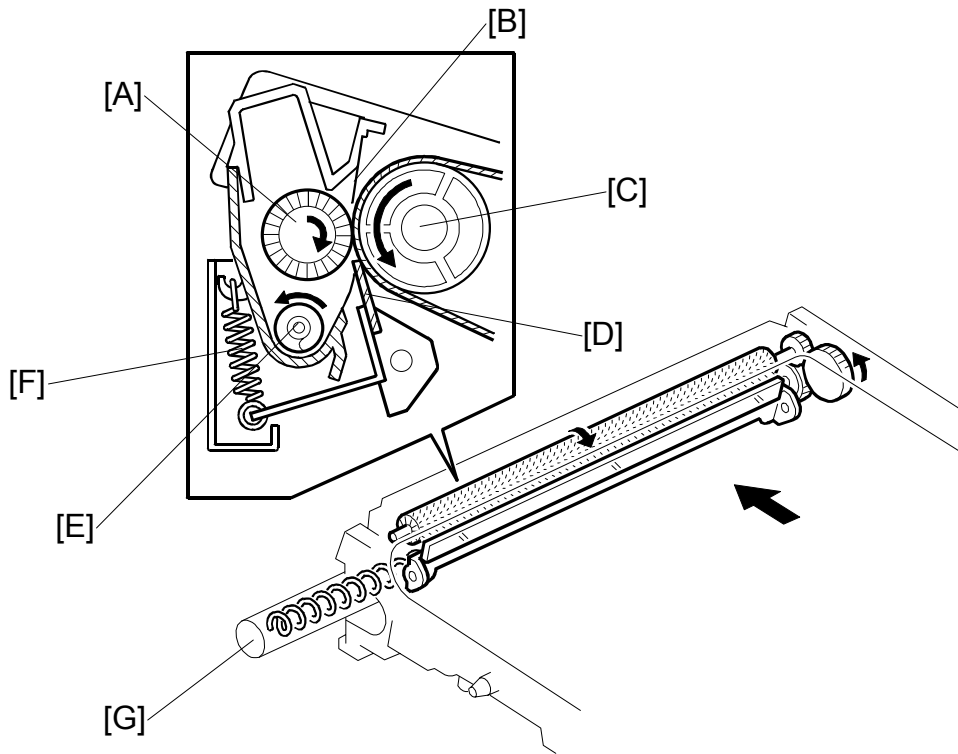

G105D114.WMF

- | | |
|--------------------------------|----------------------------------|
| [A] Cleaning brush | [D] Transfer belt cleaning blade |
| [B] Seal | [E] Toner collection coil |
| [C] Transfer belt drive roller | [F] Pressure spring |

The transfer belt cleaning blade removes remaining toner from the transfer belt to prevent “ghosting” on the next print. This blade is included in the blade holder. The pressure spring applies pressure to the center of the blade holder. This blade gets constant pressure because of the pressure spring.

The toner collection coil moves the remaining toner to the waste toner bottle from its opening [G].

6.7.3 TRANSFER ROLLER UNIT

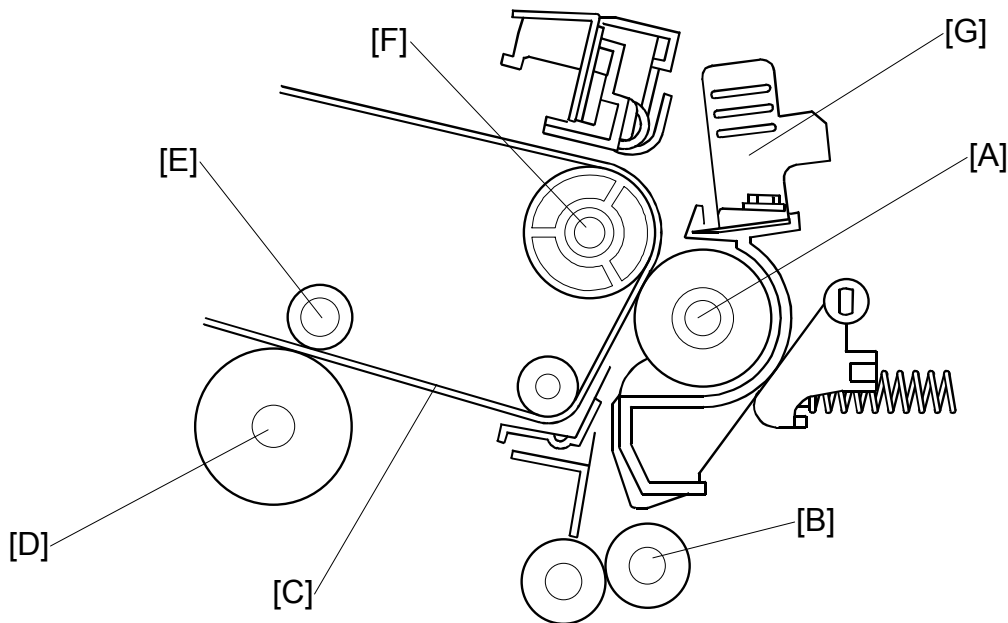

G105D116.WMF

- | | |
|-------------------------|--------------------------------|
| [A] Transfer roller | [E] Belt transfer roller |
| [B] Registration roller | [F] Transfer belt drive roller |
| [C] Transfer belt | [G] Discharge plate |
| [D] OPC | |

Transfer from the belt

The belt transfer roller [E] is given a positive voltage, and this pulls the toner from OPC [D] to the transfer belt.

After all four layers of toner are transferred to the transfer belt [C], the registration roller [B] turns on and feeds the paper to the transfer roller [A]. Paper feed is timed to align the leading edge of the toner image on the belt at 4 mm from the leading edge of the paper. The paper moves at the same speed as the transfer belt.

Image transfer

Charged with a negative voltage, the transfer belt drive roller [F] pushes out the toner from the transfer belt to the paper. This voltage is automatically corrected for the ambient temperature and humidity, print speed, and paper type.

To clean the transfer roller, positive and negative voltages are applied to this roller to pull toner particles from the transfer roller to the belt. The belt-cleaning mechanism then removes this toner from the belt.

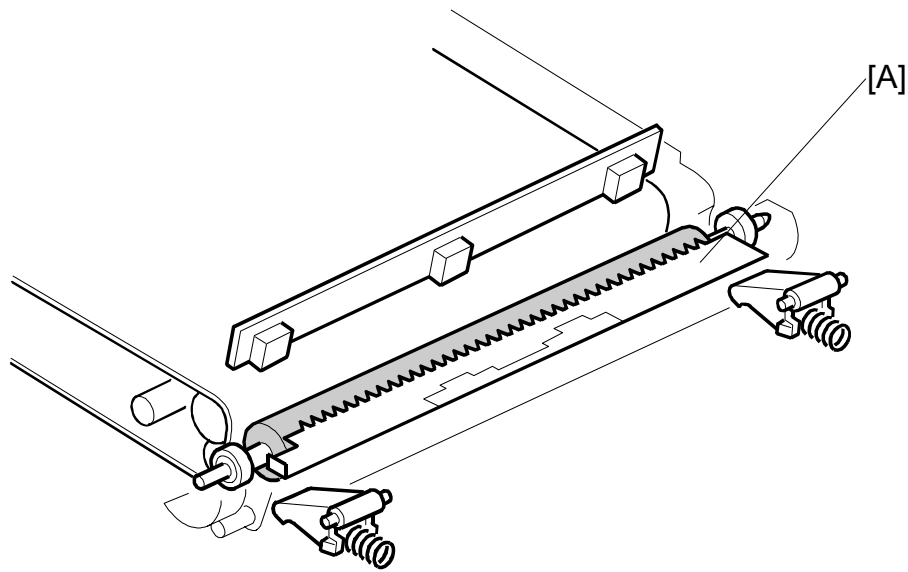
Discharge

G105D117.WMF

The discharge plate [A] removes remaining voltage from the printed paper. This is given a positive voltage. As a result, the voltage is cancelled and paper separation from the transfer belt occurs.

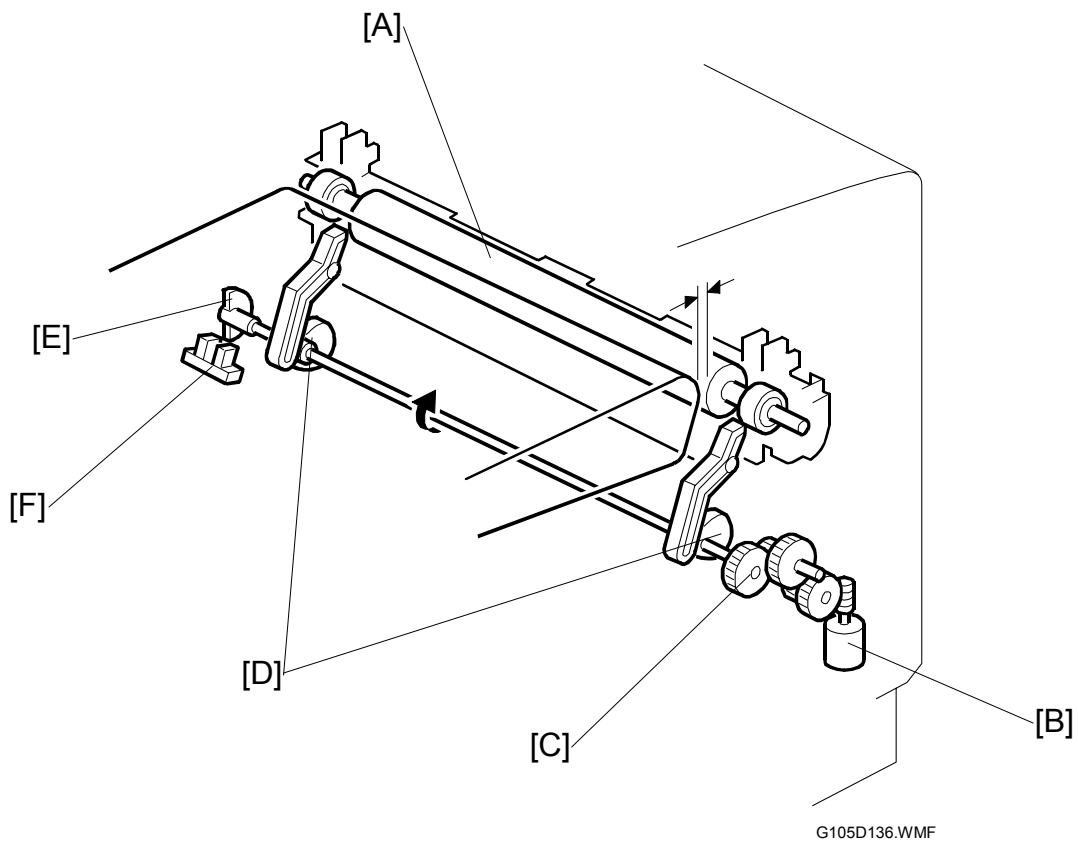
Transfer roller contact

The transfer roller [A] is kept away from the transfer belt during the machine ready condition.

When printing starts, the transfer roller contact motor [B] turns the cam shaft [C]. This shaft has two cams [D] and an actuator [E]. The two cams push the transfer roller contact levers and these push the transfer roller against the transfer belt. The actuator turns on the transfer roller contact sensor [F] when the cam shaft turns. Then, the machine detects that the transfer roller touches the transfer belt.

6.8 FUSING

6.8.1 OVERVIEW

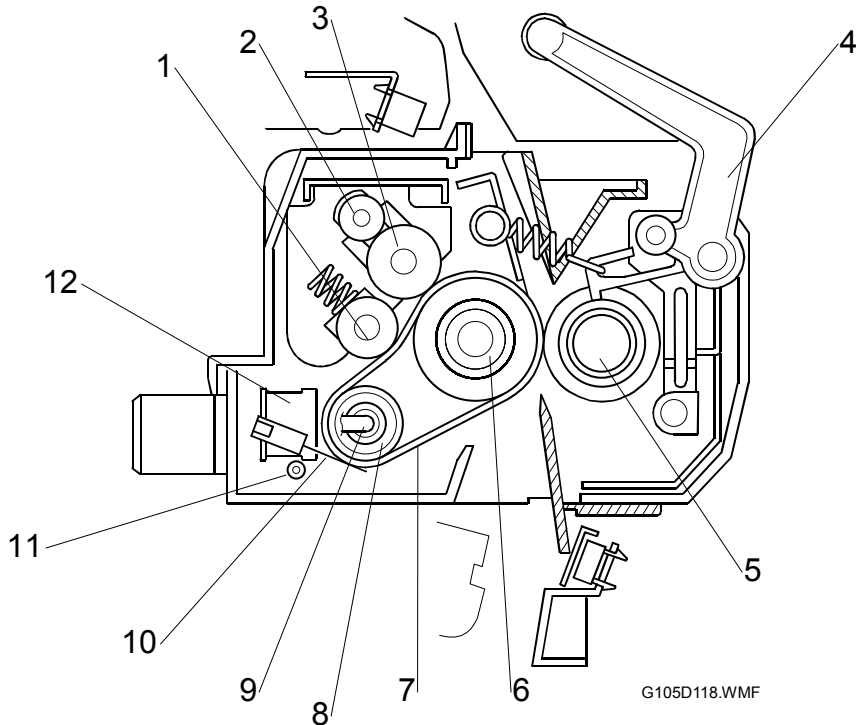

- | | |
|--------------------------|---------------------------------------|
| 1. Fusing tension roller | 7. Fusing belt |
| 2. Cleaning roller | 8. Heating roller |
| 3. Oil supply roller | 9. Heating lamp |
| 4. Pressure lever | 10. Thermistor |
| 5. Pressure roller | 11. New fusing unit
detection fuse |
| 6. Hot roller | 12. Thermostat |

- A belt fusing system is used. This has a faster warm-up time than a standard hot and pressure roller system.
- The heating roller is made of aluminum to increase the temperature of the fusing belt quickly.
- The hot roller is made of sponge, which becomes a little flat, and this increases the fusing nip. This roller does not contain a heating lamp.
- The heating roller thermistor controls the temperature of the lamp.
- Each new fusing unit contains a fuse. A short time after a new fusing unit is installed, this fuse blows. When this occurs, the machine detects that a new fusing unit is installed.

The oil supply roller supplies oil to the fusing belt through the oiling roller. This mechanism applies a constant thickness of oil to the fusing belt.

6.8.2 FUSING TEMPERATURE CONTROL

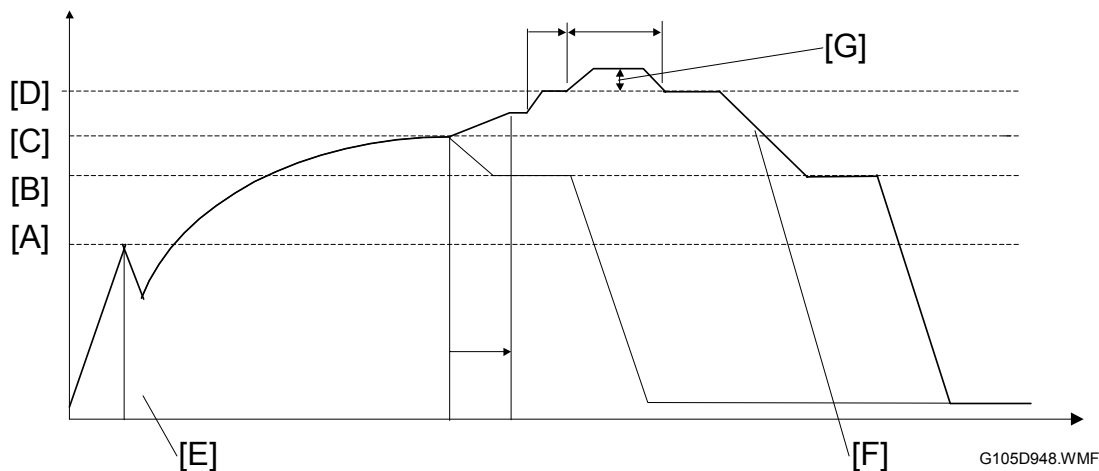

The machine starts to warm up the fusing unit to get the print ready condition. When the heating roller temperature gets to the idling ready temperature [A], the idling procedure starts to warm up the heating roller. The temperature becomes higher than the machine ready temperature [B] and gets to the print ready temperature [C] after the heating roller completes the idling.

The temperature increases to the target printing temperature. Then printing starts. If the temperature does not get to the target printing temperature before 30 seconds (SP 1104 022), printing starts.

The temperature increases to the first print temperature [G] when the first sheet of paper is printed, but this is only for the first page.

After the printing job, the machine turns the heating roller to prevent overheating [F].

You can adjust the fusing temperature settings.

Fusing roller idling

This is done at three times:

- Immediately after the power is turned on, or when the machine comes back from energy saver mode, if the fusing unit temperature is less than 100°C. This is [E] on the diagram. This idling keeps the heating roller warmed up equally while it is heated. This temperature is controlled with SP 1912-005, and the durations of fusing idling are controlled with SP 1912-006, and 008 to 013 You can also adjust this with SP1912-002 and 1105-043
- At the end of a job: [F] This prevents the heating roller's overheating. After printing, the machine turns the heating roller with no heating. You can adjust the setting with SP1912 007
- At intervals of 4 hours if the machine is not used for a long time This prevents the deformation of the hot roller and pressure roller.
 - Controlled by SP 1912-003 (interval) and 004 (duration)
 - Enable/disable this idling feature: 1912-001

For fusing idling at the start of a job, the duration and the fusing unit temperature during idling are also corrected for ambient temperature. SP 1917 controls all the corrections. The temperature/humidity sensor measures the room temperature. Corrections are made if:

- Room temperature is below 18°C (L threshold, controlled by SP 1917-008)
- Room temperature is above 30°C (H threshold, controlled by SP 1917-007)

***Idling ready temperature before first print job:* [A]**

This is the idling ready temperature for the heating roller before the first print job. You can adjust the setting with SP1912-005. The default is 100°C. If the heating roller temperature does not reach this temperature within 15 seconds after the heating lamp turns on, SC 542 occurs.

***Machine ready temperature:* [B]**

You can adjust the setting with SP1913-002. The default is 150°C.

***Print ready temperature:* [C]**

You can adjust the setting with SP1105-022. The default is 160°C.

***Target printing temperature:* [D]**

This is adjusted by the value stored in SP1104-023. This value is added to the print ready temperature. The default is 5°C.

***First print temperature:* [G]**

When the machine prints the first page, the heating roller temperature can easily decrease. If necessary, you can increase the temperature for the first page. This is a good adjustment for cold environments.

If fusing is not sufficient for the first page of a job, adjust these SPs:

- Temperature increase for the first page of a job: SP 1104-025
This value is added to the target printing temperature. The default is 0°C.
- Duration for application of the temperature increase: SP 1104-026
- The increase is applied if the interval between jobs is greater than these values:
 - OHP, Thick paper, or 1200 x 1200 dpi: SP 1104-024
 - Other types of job: SP 1104-027

Corrections for Small Paper Sizes (less than A5)

These corrections prevent too much heating of the fusing unit when paper widths less than A5 are used. In multi-page printing with this size of paper, the heating roller's temperature is not the same in all areas because the small size paper does not go through the two ends of the heating roller. The temperature of locations that do not touch the paper becomes higher than other locations during multi-page printing. These corrections decrease this problem.

- Print speed: This is decreased after 15 pages. Then, 30 seconds after this, the print speed increases to the standard temperature again. You can adjust with SP 1911-001 to 003.
- Fusing temperature: This is decreased in three stages, as shown below.
 - Decreased by 5°C after 50 pages are printed (controlled by SP 1911-004 and 014)
 - Decreased by 5°C again after 50 more pages are printed (controlled by SP 1911-006 and 016)
 - Reduced by 5°C again after 50 more pages are printed (controlled by SP 1911-008 and 018)

There are also temperature reductions for one-sided printing and two-sided printing.

- One sided printing: The temperature is decreased in two steps, as shown below
 - After 15 pages, no reduction (controlled by SP 1911-021 and 023)
 - After 15 more pages, decreased by 5°C (controlled by SP 1911-022 and 024)
- Duplex printing: The temperature is decreased in two steps, as shown below
 - After 15 pages, no reduction (controlled by SP 1911-025 and 027)
 - After 15 more pages, decreased by 10°C (controlled by SP 1911-026 and 028)

Overheat Protection

- If the heating roller temperature becomes higher than 230°C, the CPU cuts off the power to the heating lamp SC543 occurs.
- If 250°C is detected, the thermostat is opened, and then the heating lamp power is cut off. SC545 occurs.

NOTE: 1) If the thermistor output is less than 0°C for six seconds, SC541 occurs.
2) If the heating lamp gets full power for 8 seconds after the heating roller gets to the print ready temperature, SC545 occurs.

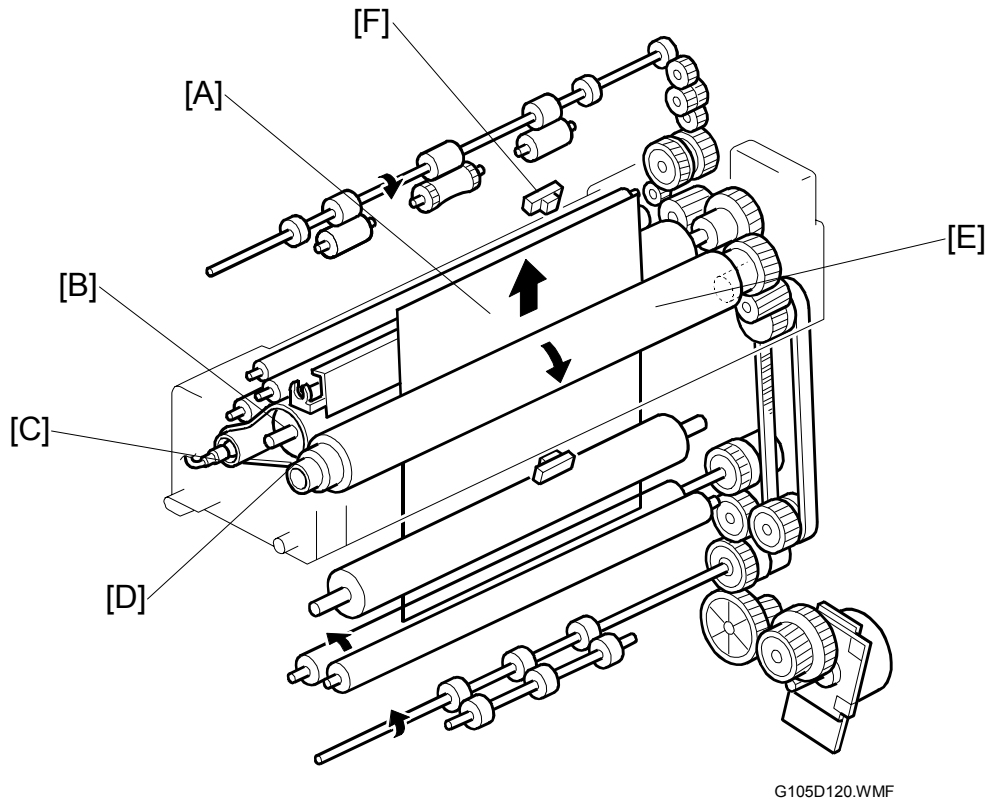
6.8.3 DRIVE

After the toner image is transferred to the paper [A], it goes through the fusing unit. The fusing unit contains the heating roller [B]. The heating lamp [C] applies heat to the heat roller. The heat roller applies heat to the fusing belt [D] to melt the toner on the paper. The paper receives pressure between the fusing belt and the pressure roller [E], and melted toner bonds to the paper.

When the paper goes out of the fusing unit, it goes to the exit tray. The paper exit sensor [F] detects paper jams.

6.9 CONTROLLER

6.9.1 OVERVIEW

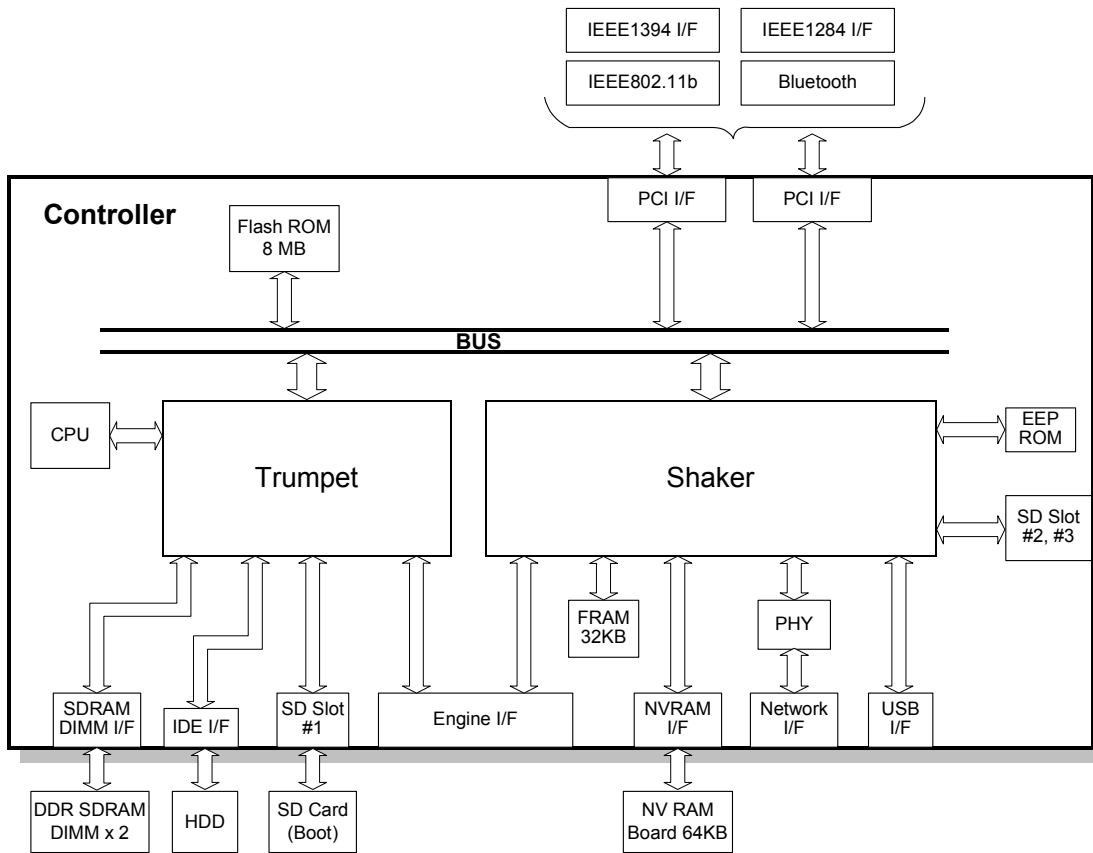

G105D920.WMF

The controller uses GW (Ground Work) architecture.

1. **CPU:** PMC RM7035C (533MHz)
2. **TRUMPET:** GW architecture ASIC. It controls the interface with the CPU and controls these functions: memory, local bus interrupts, PCI bus, video data, HDD, SD card for booting and image processing.
3. **SHAKER:** IO control ASIC. It controls the network, operation panel, USB port, SD cards.
4. **SDRAM DIMM (2 slots):**
 Model G-P1a: 128 MB SDRAM (resident)
 Model G-P1b: 256 MB SDRAM (resident)
 Can be increased to 512 MB with two 256 MB SDRAM.
5. **Flash ROM:** 8 MB flash ROM programmed for the boot system.
6. **SD card (Boot):** The 32 MB SD card installed in the SD card slot #1 includes the program for system, network application, printer, PCL5c, PS3 and RPCS applications and internal printer fonts.

Detailed Descriptions

7. **NVRAM:** 32 KB FRAM for the printer parameters, logged data and a record of the number of pages printed for each “User Code”.
8. **NVRAM board (option):** 96B NVRAM increases the number of “User Codes” form 100 to 500.
9. **Network Interface:** 100BASE-TX/10BASE-T
10. **USB Interface:** USB2.0
11. **IEEE 1394 Interface (option):** Supports a data transfer speed of up to 400 Mbps.
12. **IEEE 1284 Interface (option):** This is the parallel printer port.
13. **IEEE 802.11b (option):** This lets you connect the printer to a wireless network.
14. **Bluetooth (option):** This lets you connect the printer to a Bluetooth network.
15. **HDD:** A 2.5” HDD (40 GB) can be connected using the IDE interface.
Model G-P1a: Option
Model G-P1b: Standard

16. **SD Card slots:**

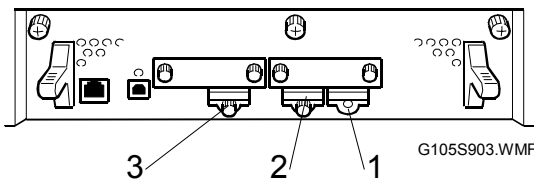

Slots 1 to 3, numbered from right to left.

- Slot 1: Boot SD card
- Slot 2: Customer’s application (for example, PostScript 3)
- Slot 3: Service use (for example, firmware upgrade), customer’s application

- 1) The system and application software for the following boards can be downloaded from SD cards connected to slot #3.
 - Controller (Flash ROM and SD card for boot)
 - EGB (Engine board)

NOTE: See the Service Tables Firmware Update Procedure for details on downloading software from the SD card.

- 2) An SD Card programmed with an additional application can be installed in SD Card slot #2 or #3. Use slot 2 first. If an additional application cannot be merged onto the card on slot 2, then use slot 3 for that additional application. If possible, keep slot #3 empty for the firmware update.

6.9.2 BOARD LAYOUT

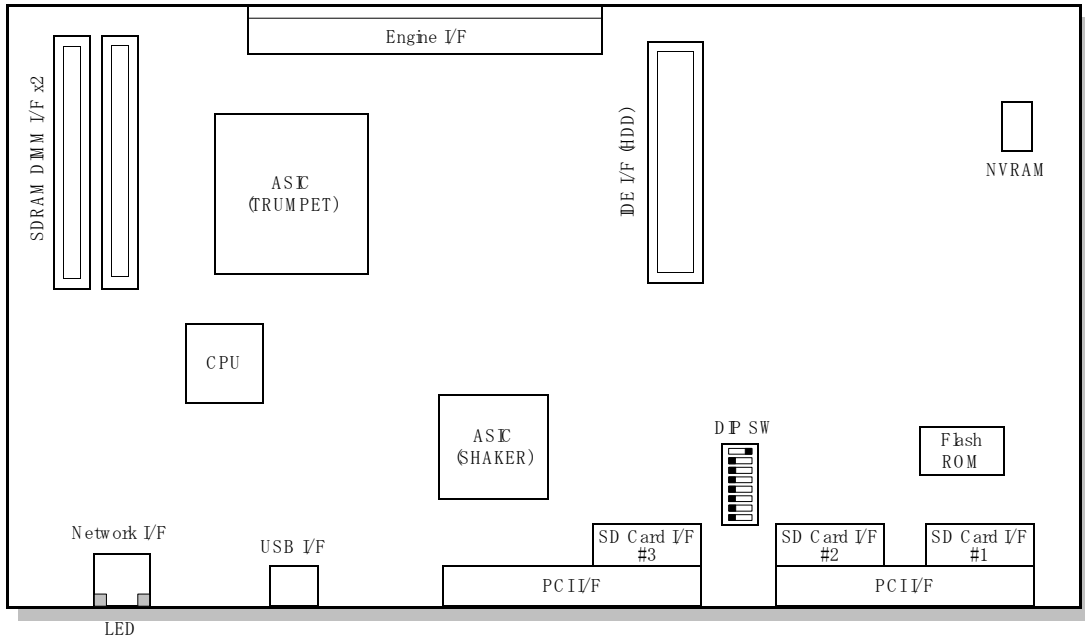

G105D922.WMF

DIP Switches: Factory use only. Keep DIP SW 1 ON and the other switches OFF.

Detailed Descriptions

SPECIFICATIONS

1. GENERAL SPECIFICATIONS

- Configuration: Desktop
- Print Process: Laser beam scanning & Electro photographic printing
4 drums tandem method
- Printer Languages: RPCS (Refined Printing Command Stream)
PCL5c/e
PCL-XL
Adobe PostScript 3
PDF
- Resolution: RPCS:
1200 x 1200 dpi, 1200 x 600 dpi, 600 x 600 dpi
PCL5c/e:
600 x 600 dpi 300 x 300 dpi
PCL-XL:
1200 x 1200 dpi, 1200 x 600 dpi, 600 x 600 dpi
Adobe PostScript 3:
1200 x 1200 dpi, 1200 x 600 dpi, 600 x 600 dpi
PDF:
1200 x 1200 dpi, 1200 x 600 dpi, 600 x 600 dpi
- Gradation 1 bit/256 gradations
- Printing speed:

	Resolution	Plain paper	Thick/OHP
Monochrome	600 x 600 dpi	25 ppm	12.5 ppm
	1200 x 600 dpi	25 ppm	12.5 ppm
	1200 x 1200 dpi	12.5 ppm	12.5 ppm
Color	600 x 600 dpi	25 ppm	12.5 ppm
	1200 x 600 dpi	25 ppm	12.5 ppm
	1200 x 1200 dpi	12.5 ppm	12.5 ppm

- Resident Fonts: PCL5c:
35 Manager Intelli fonts
10 TrueType fonts
1 Bitmap font
Adobe PostScript 3:
136 fonts (24 Type 2 fonts, 112 Type 14 fonts)
- Host Interfaces: Ethernet (10/100 Base-TX): Standard
USB2.0: Standard

IEEE1394 (SCSI print, IP over 1394): Optional
IEEE802.11b (Wireless LAN): Optional
Parallel (IEEE1284: Optional): Optional
Bluetooth (Wireless): Optional
- Network Protocols: TCP/IP, IPX/SPX, NetBEUI, AppleTalk



First Print Speed: Color: 15 seconds or less (from tray 1)
 Black & White: 10 seconds or less (from tray 1)

Warm-up Time Less than 30 seconds (at 23°C/50%)

Print Paper Capacity: Standard tray: 550 sheets
 (80 g/m², 20lb) By-pass tray: 100 sheets
 Optional paper feed tray: 550 sheets

Print Paper Size: (Refer to "Supported Paper Sizes".)

	Minimum	Maximum
Standard Tray	A4 / B5 / 8 1/2" 11" / 8 1/2" x 14" (SEF)	
By-pass	90 x 148 mm	216 x 356 mm
Optional Tray	A4 / B5 / 8 1/2" x 11" / 8 1/2" x 14" (SEF)	

Printing Paper Weight: Standard tray, Optional paper tray, and bypass tray
 One-sided: 52-216 g/m² (16-55 lb)
 Duplex: 60-157 g/m² (16-43 b)

Paper weight settings at printer driver and operation panel:

- Thin: 52 – 60.2 g/m²
- Plain paper 1 (Plain): 60.2 – 90.2 g/m²
- Plain paper 2 (Plain & Recycled): 90.2 – 104.7 g/m²
- Thick paper 1: 104.7 – 157 g/m²
- Thick paper 2: 157 – 216 g/m²

Output Paper Capacity: Standard exit tray: 500 sheets (face down)

Memory: Standard 128/ 256 MB, up to 512 MB with optional Memory Unit

Power Source: 120 V, 60 Hz: More than 11 A (for North America)
 220 V - 240 V, 50/60 Hz: More than 6 A (for Europe/Asia)

Power Consumption:

	120 V	220-240 V
Maximum	990 W or less	1200 W or less
Energy Saver	6 W or less	6 W or less

Noise Emission:
 (Sound Power Level)

	Mainframe Only	Full System
Printing	63 dB or less	67 dB or less
Stand-by	40 dB or less	40 dB or less

NOTE: The above measurements were made in accordance with ISO9296 at the operator position.

Dimensions (W x D x H): 446 x 589.5 x 487 mm (17.4" x 23.2" x 19.2")

Weight: Less than 50 kg (110.3 lb.)

2. SUPPORTED PAPER SIZES

Paper	Size (W x L)	Main Tray		PFU		By-pass Tray		Duplex	
		NA	E/A	NA	E/A	NA	E/A		
A3	297 x 420 mm	N	N	N	N	N	N	N	
A4 SEF	210 x 297 mm	Y	Y	Y	Y	Y	Y	Y	
A4 LEF	297 x 210 mm	N	N	N	N	N	N	N	
A5 SEF	148 x 210 mm	Y [#]	Y	Y [#]	Y	Y [#]	Y	Y	
A5 LEF	210 x 148 mm	N	N	N	N	N	N	N	
A6 SEF	105 x 148 mm	Y [#]	Y	N	N	Y [#]	Y	Y	
B4 SEF	257 x 364 mm	N	N	N	N	N	N	N	
B5 SEF	182 x 257 mm	Y [#]	Y [#]	Y [#]	Y [#]	Y [#]	Y [#]	Y	
B5 LEF	257 x 182 mm	N	N	N	N	N	N	N	
B6 SEF	128 x 182 mm	Y [#]	Y [#]	Y [#]	Y [#]	Y [#]	Y [#]	Y	
Ledger	11" x 17"	N	N	N	N	N	N	N	
Letter SEF	8.5" x 11"	Y	Y	Y	Y	Y	Y [#]	Y	
Letter LEF	11" x 8.5"	N	N	N	N	N	N	N	
Legal SEF	8.5" x 14"	Y	Y	Y	Y	Y [#]	Y [#]	Y	
Half Letter SEF	5.5" x 8.5"	Y	Y [#]	Y	Y [#]	Y	Y [#]	Y	
Executive SEF	7.25" x 10.5"	Y	Y	Y	Y	Y	Y [#]	Y	
Executive LEF	10.5" x 7.25"	N	N	N	N	N	N	N	
F SEF	8" x 13"	Y [#]	Y [#]	Y [#]	Y [#]	Y [#]	Y [#]	Y	
Foolscap SEF	8.5" x 13"	Y [#]	Y [#]	Y [#]	Y [#]	Y [#]	Y [#]	Y	
Folio SEF	8.25" x 13"	Y [#]	Y [#]	Y [#]	Y [#]	Y [#]	Y [#]	Y	
8K	267 x 390 mm	N	N	N	N	N	N	N	
16K SEF	195 x 267 mm	Y [#]	Y [#]	Y [#]	Y [#]	Y [#]	Y [#]	Y	
16K LEF	267 x 195 mm	N	N	N	N	N	N	N	
Custom	Width	70 x 216 mm ^{*1}	Y [#]	Y [#]	Y [#]	Y [#]	Y [#]	Y [#]	N
	Length	5.5" x 14" ^{*2}	Y [#]	Y [#]	Y [#]	Y [#]	Y [#]	Y [#]	N
		14" ~ 900 mm	N	N	N	N	Y [#]	Y [#]	N
Postcard	100 x 148 mm	Y [#]	Y [#]	N	N	Y [#]	Y [#]	N	
Double postal card	200 x 148 mm	Y [#]	Y [#]	Y [#]	Y [#]	Y [#]	Y [#]	N	
Com10 Env.	4.125" x 9.5"	Y [#]	Y [#]	Y [#]	Y [#]	Y [#]	Y [#]	N	
Monarch Env.	3.875" x 7.5"	Y [#]	Y [#]	Y [#]	Y [#]	Y [#]	Y [#]	N	
C6 Env.	114 x 162 mm	Y [#]	Y [#]	Y [#]	Y [#]	Y [#]	Y [#]	N	
C5 Env.	162 x 229 mm	Y [#]	Y [#]	Y [#]	Y [#]	Y [#]	Y [#]	N	
DL Env.	110 x 220 mm	Y [#]	Y [#]	Y [#]	Y [#]	Y [#]	Y [#]	N	

*1: This size is only for the by-pass tray. The size for the main tray and OPU is 98 mm.

*2: This size is only for the main tray and by-pass tray. The size for OPU is 148 mm.

Remarks:

Y	Supported: the sensor detects the paper size.
Y [#]	Supported: the user specifies the paper size.
N	Not supported

Spec.

3. SOFTWARE ACCESSORIES

The printer drivers and utility software are provided on one CD-ROM. An auto-run installer allows you to select which components to install.

3.1 PRINTER DRIVERS

Printer Language	Windows 95/98/ME	Windows NT4.0	Windows 2000	Windows XP	Macintosh
PCL 5c/6	Yes	Yes	Yes	Yes	No
PS3	Yes	Yes	Yes	Yes	Yes
RPCS	Yes	Yes	Yes	Yes	No

- NOTE:** 1) The printer drivers for Windows NT 4.0 are only for the Intel x86 platform. There is no Windows NT 4.0 printer driver for the PowerPC, Alpha, or MIPS platforms.
- 2) The PS3 drivers are all genuine AdobePS drivers, except for Windows 2000, which uses Microsoft PS. A PPD file for each operating system is provided with the driver.
- 3) The PS3 driver for Macintosh supports Mac OS 7.6 or later versions.

3.2 UTILITY SOFTWARE

Software	Description
Font Manager 2000 (Win95/98/Me, NT4.0, 2000, XP, Server2003)	A font management utility with screen fonts for the printer
Smart Device Monitor for Admin (Win95/98/Me, NT4.0, 2000, XP, Server2003)	A printer management utility for network administrators. NIB setup utilities are also available.
Smart Device Monitor for Cloant (Win95/98/Me, NT4.0, 2000, XP, Server2003)	<ul style="list-style-type: none"> • A printer management utility for client users. • A utility for peer-to-peer printing over a NetBEUI or TCP/IP network. • A peer to peer print utility over a TCP/IP network. This provides the parallel printing and recovery printing features.
Printer Utility for Mac (Mac)	This software provides several convenient functions for printing from Macintosh clients.
IEEE1394 Utility (Win2000, XP, Server2003)	This utility solves problems with Windows 2000, XP, Server2003.
DeskTopBinder V2 Lite (Win95/98, 2000, NT4, XP, Server2003)	DeskTopBinder V2 Lite itself can be used as personal document management software and can manage both image data converted from paper documents and application files saved in each client's PC.

4. MACHINE CONFIGURATION

Item	Machine Code	No.	Remarks
Main Unit	G104		Standard model (128 MB memory, no HDD)
	G105		High specification model (256 MB memory, HDD standard)
Options			
Paper Feed Unit	G392		Up to two trays unit can be installed.
Internal Options			
128 MB DIMM Memory	B584		
256 MB DIMM Memory	G818		
NVRAM Memory	G395		
IEEE1284 I/F Board	B679		Used in common with model K-C2
IEEE1394 I/F Board	B581		
IEEE802.11b Board	G813		
Bluetooth Board	B736		
HDD Type 4000	G395		
Network Data Protection Unit Type A	G820		

NOTE: 1) Two of the IEEE1394, IEEE1284, IEEE802.11b, and Bluetooth can be installed at the same time.

5. OPTIONAL EQUIPMENT

Paper Feed System:	Friction Pad
Paper Height Detection:	5 steps (100%, 70%, 30%, Near End and Empty)
Capacity:	550 sheets x 1 tray (80 g/m ² , 20 lb)
Paper Weight:	52 to 216 g/m ² (14 to 58 lb)
Paper Size	A4 / B5 / 8 ¹ / ₂ " x 11" / 8 ¹ / ₂ " x 14" (SEF)
Power Source:	DC 24 V, 5 V (from the main frame)
Power Consumption:	Less than 15 W
Dimension (W x D x H):	446 x 576 x 150 mm
Weight:	8.5 kg (18 lb)